

# SECO SV 1063–1100 B/C

Dry-running rotary vane vacuum pumps



Discover all advantages of the product series SECO SV

## Compact

Direct-drive construction

## Reliable

Robust construction, proven performance, self-lubricating vanes, no operating fluids

## High performance

High uptime, high performance vanes

### Accessories

- Inlet filter
- Vacuum regulation valve
- Vacuum relief valve for SV 1063/1080 B
- Non-return valve (inlet)
- Hose nipple

# SECO SV 1063–1100 B/C

Dry-running rotary vane vacuum pumps



## Dimensional drawing

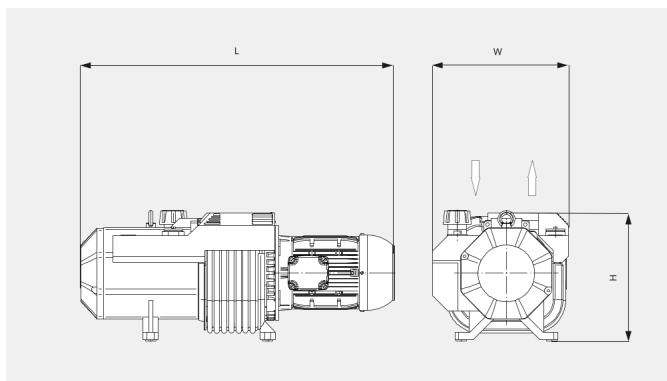

## Pumping speed

Air at 20 °C. Tolerance: ± 10%

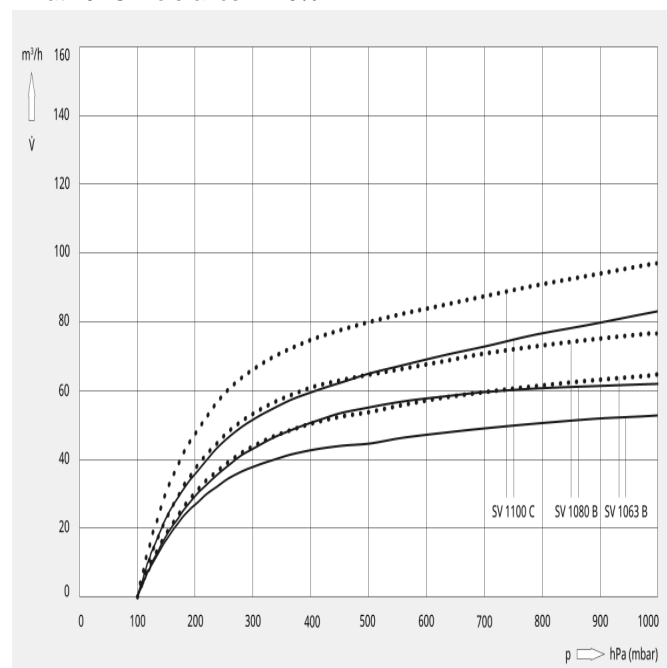

The following technical values refer to ISO 50 Hz

	SECO SV 1063 B	SECO SV 1080 B	SECO SV 1100 C
<b>Nominal pumping speed</b>	55 m <sup>3</sup> /h	62 m <sup>3</sup> /h	83 m <sup>3</sup> /h
<b>Ultimate pressure</b>	100 hPa (mbar)	100 hPa (mbar)	100 hPa (mbar)
<b>Nominal motor rating</b>	1.7 kW	2.2 kW	3.0 kW
<b>Nominal motor speed</b>	1500 min <sup>-1</sup>	1500 min <sup>-1</sup>	1500 min <sup>-1</sup>
<b>Noise level (ISO 2151)</b>	75 dB(A)	76 dB(A)	77 dB(A)
<b>Weight approx.</b>	82 kg	90 kg	120 kg
<b>Dimensions (L x W x H)</b>	763 x 428 x 342 mm	798 x 428 x 342 mm	849 x 375 x 346 mm
<b>Gas inlet</b>	G 1¼"	G 1¼"	G 1¼"
<b>Gas outlet</b>	G 1¼"	G 1¼"	G 1¼"

# SECO SV 1063–1100 B/C

Dry-running rotary vane vacuum pumps



The following technical values refer to ISO 60 Hz

	SECO SV 1063 B	SECO SV 1080 B	SECO SV 1100 C
<b>Nominal pumping speed</b>	65 m <sup>3</sup> /h	77 m <sup>3</sup> /h	97 m <sup>3</sup> /h
<b>Ultimate pressure</b>	100 hPa (mbar)	100 hPa (mbar)	100 hPa (mbar)
<b>Nominal motor rating</b>	2.2 kW	3.0 kW	4.0 kW
<b>Nominal motor speed</b>	1800 min <sup>-1</sup>	1800 min <sup>-1</sup>	1800 min <sup>-1</sup>
<b>Noise level (ISO 2151)</b>	76 dB(A)	77 dB(A)	78 dB(A)
<b>Weight approx.</b>	82 kg	90 kg	120 kg
<b>Dimensions (L x W x H)</b>	763 x 428 x 342 mm	798 x 428 x 342 mm	849 x 375 x 346 mm
<b>Gas inlet</b>	G 1¼"	G 1¼"	G 1¼"
<b>Gas outlet</b>	G 1¼"	G 1¼"	G 1¼"

## DO YOU WANT TO KNOW MORE

Please contact us!  
sales@busch.co.nz or +64 (0)800 428 724



CONTACT FORM



CALL US NOW