

PANDA WV 1200–2400 A

Vacuum boosters

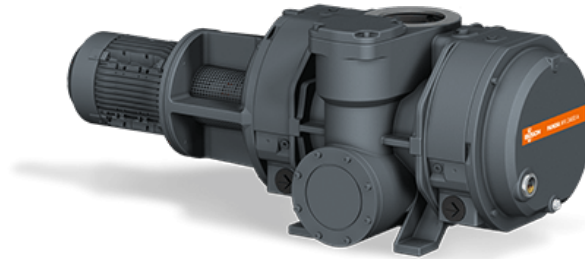

Discover all advantages of the product series PANDA WV

Reliable

Solid lobe design, robust construction made of GGG40 material, reliable under varying operating conditions, barrier gas connection, standard mechanical shaft seals, perfectly suited for chemical processes

High performance

Excellent volumetric efficiency, high ultimate pressure, increases the performance of a vacuum system by up to a factor of ten, integrated bypass valve, specially designed for rough and medium vacuum applications

Flexible

Can be flanged directly on the system at any position, boosts the performance of all types of backing pumps, with vertical or lateral discharge

PANDA WV 1200–2400 A

Vacuum boosters



Dimensional drawing

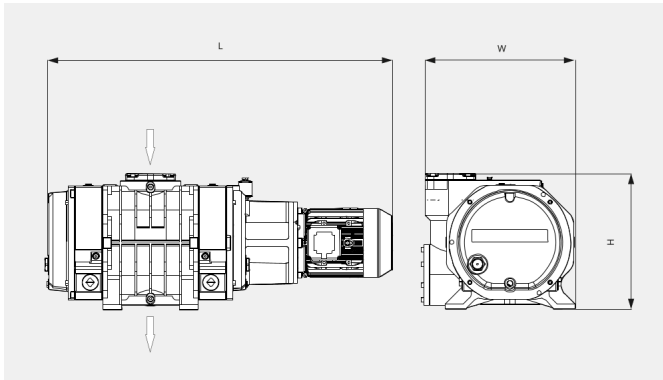

Pumping speed

Air at 20 °C. Tolerance: ± 10%

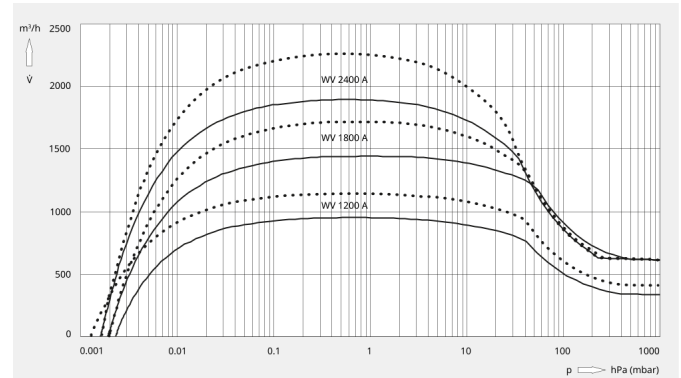

The following technical values refer to ISO 50 Hz

	PANDA WV 1200 A	PANDA WV 1800 A	PANDA WV 2400 A
Nominal pumping speed	1050 m³/h	1600 m³/h	2120 m³/h
Pumping speed	950 m³/h	1443 m³/h	1920 m³/h
Max. differential pressure	53 hPa (mbar)	53 hPa (mbar)	53 hPa (mbar)
Nominal motor rating	3.5 kW	4.3 kW	5.5 kW
Nominal motor speed	3000 min ⁻¹	3000 min ⁻¹	3000 min ⁻¹
Weight approx.	290 kg	300 kg	520 kg
Dimensions (L x W x H)	1094 x 470 x 353 mm	1114 x 470 x 398 mm	1286 x 568 x 503 mm
Gas inlet (horizontal)	DN 160 ISO	DN 160 ISO	DN 160 ISO
Gas inlet (vertical)	DN 160 ISO	DN 160 ISO	DN 160 ISO
Gas outlet (horizontal)	DN 100 ISO	DN 100 ISO	DN 160 ISO
Gas outlet (vertical)	DN 100 ISO	DN 100 ISO	DN 160 ISO

The following technical values refer to ISO 60 Hz

	PANDA WV 1200 A	PANDA WV 1800 A	PANDA WV 2400 A
Nominal pumping speed	1260 m³/h	1920 m³/h	2540 m³/h
Pumping speed	1141 m³/h	1718 m³/h	2290 m³/h
Max. differential pressure	53 hPa (mbar)	53 hPa (mbar)	53 hPa (mbar)

PANDA WV 1200–2400 A

Vacuum boosters



VACUUM SOLUTIONS

	PANDA WV 1200 A	PANDA WV 1800 A	PANDA WV 2400 A
Nominal motor rating	4.8 kW	5.2 kW	7.0 kW
Nominal motor speed	3600 min ⁻¹	3600 min ⁻¹	3600 min ⁻¹
Weight approx.	290 kg	300 kg	520 kg
Dimensions (L x W x H)	1094 x 470 x 353 mm	1114 x 470 x 398 mm	1286 x 568 x 503 mm
Gas inlet (horizontal)	DN 160 ISO	DN 160 ISO	DN 160 ISO
Gas inlet (vertical)	DN 160 ISO	DN 160 ISO	DN 160 ISO
Gas outlet (horizontal)	DN 100 ISO	DN 100 ISO	DN 160 ISO
Gas outlet (vertical)	DN 100 ISO	DN 100 ISO	DN 160 ISO

DO YOU WANT TO KNOW MORE

Please contact us!
sales@busch.co.nz or +64 (0)800 428 724



CONTACT FORM



CALL US NOW