

MINK MV 1202 B

Dry claw vacuum pump



Discover all advantages of the product series MINK MV

Quiet

Low noise level due to a state-of-the-art acoustic design, can be installed at workstations

Efficient

Latest claw vacuum technology, low energy consumption, minimized operating costs, nearly maintenance-free, effective air cooling

Compact

Small footprint

Accessories

- Aqua version
- IoT kit
- ATEX Category 3

MINK MV 1202 B

Dry claw vacuum pump



Dimensional drawing

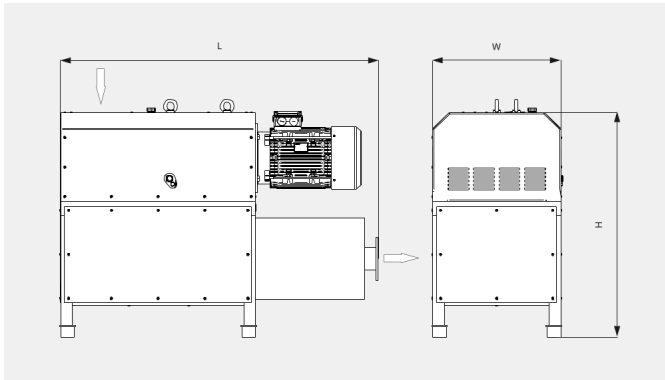

Pumping speed

Air at 20 °C. Tolerance: $\pm 10\%$

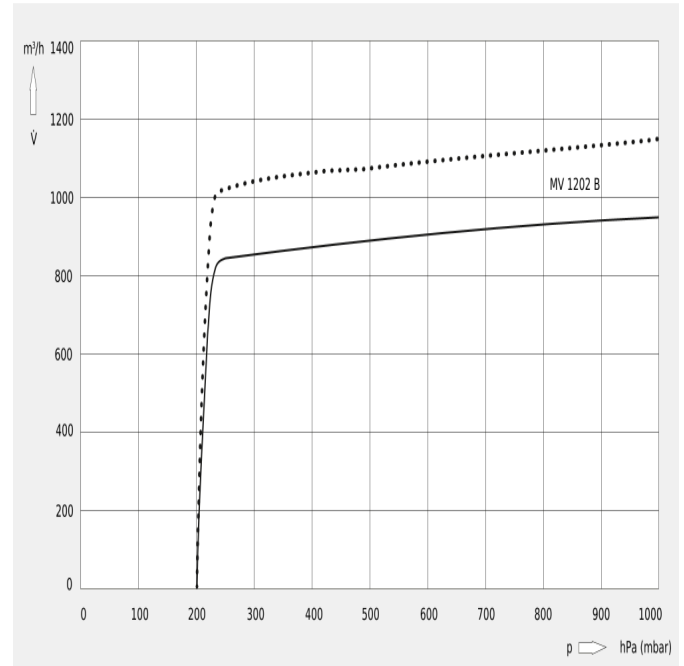

The following technical values refer to ISO 50 Hz

MINK MV 1202 B	
Nominal pumping speed	950 m³/h
Ultimate pressure	200 hPa (mbar)
Nominal motor rating	18.5 kW
Nominal motor speed	3000 min ⁻¹
Noise level (ISO 2151)	79 dB(A)
Oil capacity	3.5 l
Weight approx.	900 kg
Dimensions (L x W x H)	1620 x 670 x 1210 mm
Gas inlet	DN 100, PN 10/16
Gas outlet	DN 100, PN 10/16

MINK MV 1202 B

Dry claw vacuum pump



The following technical values refer to ISO 60 Hz

MINK MV 1202 B	
Nominal pumping speed	1150 m ³ /h
Ultimate pressure	200 hPa (mbar)
Nominal motor rating	22.0 kW
Nominal motor speed	3600 min ⁻¹
Noise level (ISO 2151)	82 dB(A)
Oil capacity	3.5 l
Weight approx.	900 kg
Dimensions (L x W x H)	1620 x 670 x 1210 mm
Gas inlet	DN 100, PN 10/16
Gas outlet	DN 100, PN 10/16

DO YOU WANT TO KNOW MORE

Please contact us!
sales@busch.co.nz or +64 (0)800 428 724



CONTACT FORM



CALL US NOW