

FOSSA FO 0015 A

Scroll vacuum pumps



Discover all advantages of
the product series FOSSA FO

Robust

Specially designed for analytical and scientific applications, for example leak detection, single-sided scroll design, dry compression, gas-tight, lifetime-lubricated bearings, minimal maintenance

Easy servicing

No special tools necessary, modular design for rapid exchange of stages

Quiet

Low noise and vibration levels, can be installed at workstations

Accessories

- Inlet filter, FIL 0080
- Exhaust filter and silencer
- Gas-ballast valve
- Gas-ballast adapter, dilution kit
- Four castor wheels
- Tip seal replacement kit

FOSSA FO 0015 A

Scroll vacuum pumps



VACUUM SOLUTIONS

Dimensional drawing

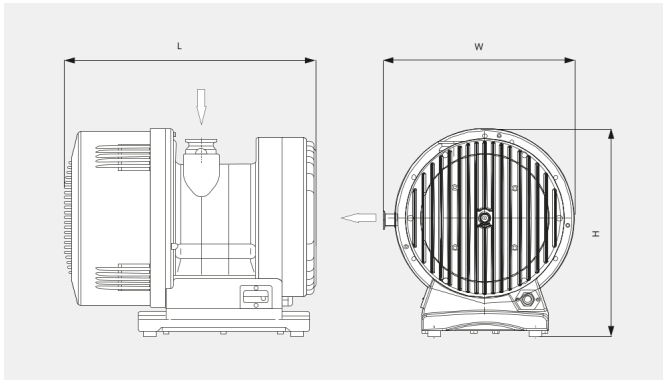

Pumping speed

Air at 20 °C. Tolerance: ± 10%

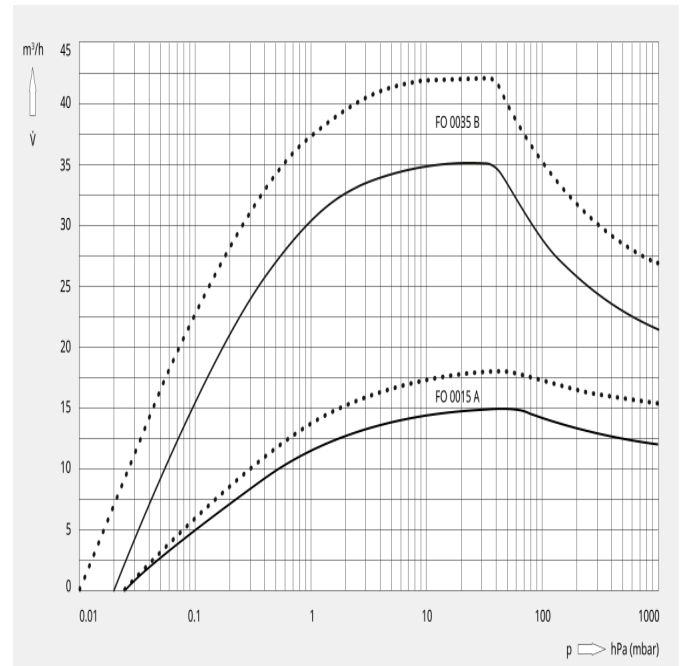

The following technical values refer to ISO 50 Hz

	FOSSA FO 0015 A (A)	FOSSA FO 0015 A (B)	FOSSA FO 0015 A (C)	FOSSA FO 0015 A (D)
Ambient temperature	5 – 40 °C	5 – 40 °C	5 – 40 °C	5 – 40 °C
Pumping speed (m³/h)	15 m³/h	15 m³/h	15 m³/h	15 m³/h
Pumping speed (l/min)	250 l/min	250 l/min	250 l/min	250 l/min
Ultimate total pressure (gas#ballast valve closed)	0.025 hPa (mbar)	0.025 hPa (mbar)	0.025 hPa (mbar)	0.025 hPa (mbar)
Ultimate total pressure (gas#ballast valve open)	0.09 hPa (mbar)	0.09 hPa (mbar)	0.09 hPa (mbar)	0.09 hPa (mbar)
Max. continuous inlet pressure	1000 hPa (mbar)	1000 hPa (mbar)	1000 hPa (mbar)	1000 hPa (mbar)
Max. back pressure	500 hPa (mbar) rel.	500 hPa (mbar) rel.	500 hPa (mbar) rel.	500 hPa (mbar) rel.
Water vapor capacity (gas#ballast valve open)	300 g/h	300 g/h	300 g/h	300 g/h
Leakage rate (helium)	< 1 · 10 ⁻⁶ mbar · l/s	< 1 · 10 ⁻⁶ mbar · l/s	< 1 · 10 ⁻⁶ mbar · l/s	< 1 · 10 ⁻⁶ mbar · l/s
Nominal motor rating	0.4 kW	0.4 kW	0.4 kW	0.4 kW

FOSSA FO 0015 A

Scroll vacuum pumps



	FOSSA FO 0015 A (A)	FOSSA FO 0015 A (B)	FOSSA FO 0015 A (C)	FOSSA FO 0015 A (D)
Nominal motor speed	1480 min ⁻¹	1480 min ⁻¹	1480 min ⁻¹	1480 min ⁻¹
Operating voltage	100 – 240 V	190 – 220 V	100 – 115 V	200 – 240 V
Motor phase	Single-phase	Three-phase	Single-phase	Single-phase
Vibration level at inlet (ISO 10816#1)	Class 1B, < 1.5 mm · s ⁻¹	Class 1B, < 1.5 mm · s ⁻¹	Class 1B, < 1.5 mm · s ⁻¹	Class 1B, < 1.5 mm · s ⁻¹
Noise level (ISO 2151)	42 dB(A) (idle mode) / 59 dB(A) (max.) dB(A)	42 dB(A) (idle mode) / 59 dB(A) (max.) dB(A)	42 dB(A) (idle mode) / 59 dB(A) (max.) dB(A)	42 dB(A) (idle mode) / 59 dB(A) (max.) dB(A)
Weight approx.	48 kg	48 kg	48 kg	48 kg
Dimensions (L x W x H)	450 x 338 x 369 mm	450 x 338 x 369 mm	450 x 338 x 369 mm	450 x 338 x 369 mm
Gas inlet	DN 40 ISO-KF	DN 40 ISO-KF	DN 40 ISO-KF	DN 40 ISO-KF
Gas outlet	DN 16 ISO-KF	DN 16 ISO-KF	DN 16 ISO-KF	DN 16 ISO-KF
Emissions and immunity	EN 61236-1:2013 as a class A device	EN 61236-1:2013 as a class A device	EN 61236-1:2013 as a class A device	EN 61236-1:2013 as a class A device
Safety	EN/IEC 61010 third edition certified	EN/IEC 61010 third edition certified	EN/IEC 61010 third edition certified	EN/IEC 61010 third edition certified

The following technical values refer to ISO 60 Hz

	FOSSA FO 0015 A (A)	FOSSA FO 0015 A (B)	FOSSA FO 0015 A (C)	FOSSA FO 0015 A (D)
Ambient temperature	5 – 40 °C	5 – 40 °C	5 – 40 °C	5 – 40 °C
Pumping speed (m³/h)	18 m ³ /h	18 m ³ /h	18 m ³ /h	18 m ³ /h
Pumping speed (l/min)	300 l/min	300 l/min	300 l/min	300 l/min
Ultimate total pressure (gas#ballast valve closed)	0.025 hPa (mbar)	0.025 hPa (mbar)	0.025 hPa (mbar)	0.025 hPa (mbar)
Ultimate total pressure (gas#ballast valve open)	0.09 hPa (mbar)	0.09 hPa (mbar)	0.09 hPa (mbar)	0.09 hPa (mbar)
Max. continuous inlet pressure	1000 hPa (mbar)	1000 hPa (mbar)	1000 hPa (mbar)	1000 hPa (mbar)
Max. back pressure	500 hPa (mbar) rel.	500 hPa (mbar) rel.	500 hPa (mbar) rel.	500 hPa (mbar) rel.
Water vapor capacity (gas#ballast valve open)	300 g/h	300 g/h	300 g/h	300 g/h
Leakage rate (helium)	< 1 · 10 ⁻⁶ mbar · l/s	< 1 · 10 ⁻⁶ mbar · l/s	< 1 · 10 ⁻⁶ mbar · l/s	< 1 · 10 ⁻⁶ mbar · l/s

FOSSA FO 0015 A

Scroll vacuum pumps



	FOSSA FO 0015 A (A)	FOSSA FO 0015 A (B)	FOSSA FO 0015 A (C)	FOSSA FO 0015 A (D)
Nominal motor rating	0.4 kW	0.4 kW	0.4 kW	0.4 kW
Nominal motor speed	1780 min ⁻¹	1780 min ⁻¹	1780 min ⁻¹	1780 min ⁻¹
Operating voltage	100 – 240 V	190 – 220 V	100 – 115 V	200 – 240 V
Motor phase	Single-phase	Three-phase	Single-phase	Single-phase
Vibration level at inlet (ISO 10816#1)	Class 1B, < 1.5 mm · s ⁻¹	Class 1B, < 1.5 mm · s ⁻¹	Class 1B, < 1.5 mm · s ⁻¹	Class 1B, < 1.5 mm · s ⁻¹
Noise level (ISO 2151)	42 dB(A) (idle mode) / 59 dB(A) (max.) dB(A)	42 dB(A) (idle mode) / 59 dB(A) (max.) dB(A)	42 dB(A) (idle mode) / 59 dB(A) (max.) dB(A)	42 dB(A) (idle mode) / 59 dB(A) (max.) dB(A)
Weight approx.	48 kg	48 kg	48 kg	48 kg
Dimensions (L x W x H)	450 x 338 x 369 mm	450 x 338 x 369 mm	450 x 338 x 369 mm	450 x 338 x 369 mm
Gas inlet	DN 40 ISO-KF	DN 40 ISO-KF	DN 40 ISO-KF	DN 40 ISO-KF
Gas outlet	DN 16 ISO-KF	DN 16 ISO-KF	DN 16 ISO-KF	DN 16 ISO-KF
Emissions and immunity	EN 61236-1:2013 as a class A device	EN 61236-1:2013 as a class A device	EN 61236-1:2013 as a class A device	EN 61236-1:2013 as a class A device
Safety	EN/IEC 61010 third edition certified	EN/IEC 61010 third edition certified	EN/IEC 61010 third edition certified	EN/IEC 61010 third edition certified

DO YOU WANT TO KNOW MORE

Please contact us!
sales@busch.co.nz or +64 (0)800 428 724



CONTACT FORM



CALL US NOW