

DOLPHIN VL 0530–0800 A

Total Recirculation

Liquid ring vacuum pump units

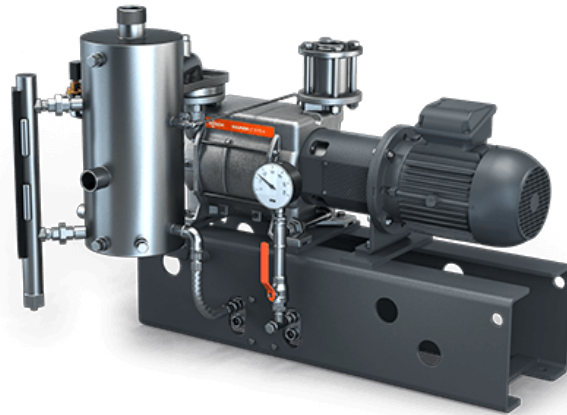

Discover all advantages of
the product series DOLPHIN
VL

Robust

Proven technology, reliable operation, corrosion-free stainless steel impeller, extremely high vapor and particle tolerance, choice of cast iron (EN-GJL-200) or 316 grade stainless steel material housings, ATEX-certified version available (Cat. 1 (i/o) IIB, T4)

All-in-One

Unit with base frame, operating fluid separator, heat exchanger, control system, including inlet check valve, fresh liquid supply kit, level indicator with switches, temperature and pressure indicators and cavitation protection

Efficient

Full recirculation of operating fluid, low operating fluid consumption, recovery of condensed vapors and process gases, isolation of cooling liquid from operating fluid, operating fluids other than water possible

DOLPHIN VL 0530–0800 A

Total Recirculation

Liquid ring vacuum pump units



Dimensional drawing

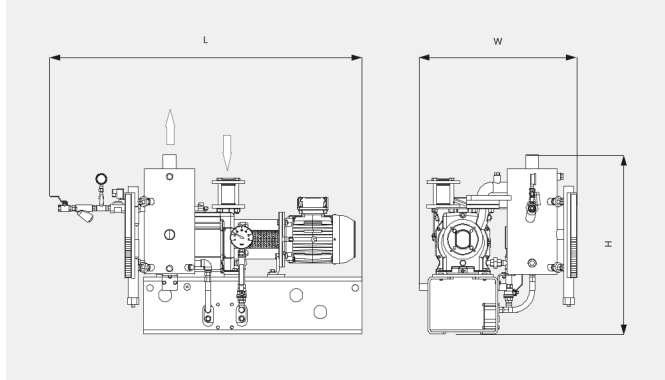

The following technical values refer to ISO 50 Hz

	DOLPHIN VL 0530 A Total Recirculation	DOLPHIN VL 0800 A Total Recirculation
Nominal pumping speed	405 m ³ /h	722 m ³ /h
Ultimate pressure	130 hPa (mbar)	130 hPa (mbar)
Nominal motor rating	11.0 kW	18.5 kW
Weight approx. ATEX	559 kg	659 kg
Weight approx. Safe Area	495 kg	573 kg
Dimensions (L x W x H) ATEX	1592 x 946 x 1248 mm	1761 x 1059 x 1431 mm
Dimensions (L x W x H) Safe Area	1490 x 893 x 1129 mm	1679 x 973 x 1144 mm
Gas inlet	G 2"	G 2½"
Gas outlet	R 3"	R 4"

The following technical values refer to ISO 60 Hz

	DOLPHIN VL 0530 A Total Recirculation	DOLPHIN VL 0800 A Total Recirculation
Nominal pumping speed	551 m ³ /h	867 m ³ /h
Ultimate pressure	130 hPa (mbar)	130 hPa (mbar)
Nominal motor rating	15.0 kW	22.0 kW
Weight approx. ATEX	559 kg	659 kg
Weight approx. Safe Area	495 kg	573 kg
Dimensions (L x W x H) ATEX	1592 x 946 x 1248 mm	1761 x 1059 x 1431 mm

DOLPHIN VL 0530–0800 A Total Recirculation

Liquid ring vacuum pump units



	DOLPHIN VL 0530 A Total Recirculation	DOLPHIN VL 0800 A Total Recirculation
Dimensions (L x W x H) Safe Area	1490 x 893 x 1129 mm	1679 x 973 x 1144 mm
Gas inlet	G 2"	G 2½"
Gas outlet	R 3"	R 4"

DO YOU WANT TO KNOW MORE

Please contact us!
sales@busch.co.nz or +64 (0)800 428 724



CONTACT FORM



CALL US NOW