

# DOLPHIN VL 0430–0750 A

## Total Recirculation

Liquid ring vacuum pump units

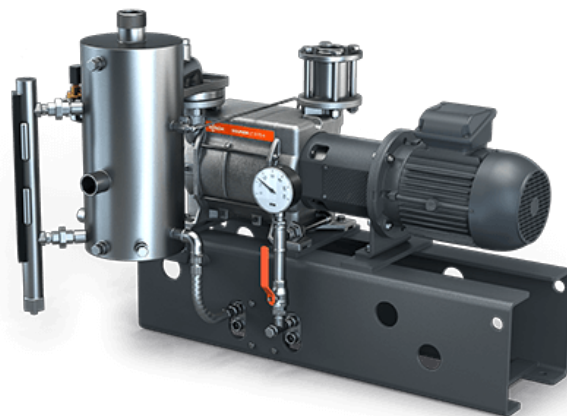

Discover all advantages of  
the product series DOLPHIN  
VL

### Robust

Proven technology, reliable operation, corrosion-free stainless steel impeller, extremely high vapor and particle tolerance, choice of cast iron (EN-GJL-200) or 316 grade stainless steel material housings, ATEX-certified version available (Cat. 1 (i/o) IIB, T4)

### All-in-One

Unit with base frame, operating fluid separator, heat exchanger, control system, including inlet check valve, fresh liquid supply kit, level indicator with switches, temperature and pressure indicators and cavitation protection

### Efficient

Full recirculation of operating fluid, low operating fluid consumption, recovery of condensed vapors and process gases, isolation of cooling liquid from operating fluid, operating fluids other than water possible

# DOLPHIN VL 0430–0750 A

## Total Recirculation

Liquid ring vacuum pump units



Dimensional drawing

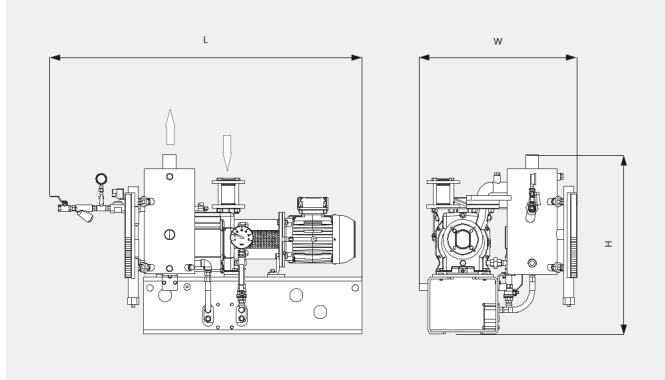

The following technical values refer to ISO 50 Hz

	DOLPHIN VL 0430 A Total Recirculation	DOLPHIN VL 0510 A Total Recirculation	DOLPHIN VL 0630 A Total Recirculation	DOLPHIN VL 0750 A Total Recirculation
<b>Nominal pumping speed</b>	340 m <sup>3</sup> /h	430 m <sup>3</sup> /h	498 m <sup>3</sup> /h	600 m <sup>3</sup> /h
<b>Ultimate pressure</b>	33 hPa (mbar)	33 hPa (mbar)	33 hPa (mbar)	33 hPa (mbar)
<b>Nominal motor rating</b>	11.0 kW	11.0 kW	15.0 kW	18.5 kW
<b>Weight approx. ATEX</b>	551 kg	579 kg	646 kg	724 kg
<b>Weight approx. Safe Area</b>	474 kg	505 kg	583 kg	641 kg
<b>Dimensions (L x W x H) ATEX</b>	1645 x 946 x 1248 mm	1704 x 946 x 1248 mm	1812 x 973 x 1431 mm	1909 x 1059 x 1431 mm
<b>Dimensions (L x W x H) Safe Area</b>	1571 x 853 x 1129 mm	1585 x 894 x 1129 mm	1750 x 973 x 1144 mm	1827 x 973 x 1144 mm
<b>Gas inlet</b>	G 2"	G 2"	G 2½"	G 2½"
<b>Gas outlet</b>	R 3"	R 3"	R 4"	R 4"

The following technical values refer to ISO 60 Hz

	DOLPHIN VL 0430 A Total Recirculation	DOLPHIN VL 0510 A Total Recirculation	DOLPHIN VL 0630 A Total Recirculation	DOLPHIN VL 0750 A Total Recirculation
<b>Nominal pumping speed</b>	419 m <sup>3</sup> /h	515 m <sup>3</sup> /h	574 m <sup>3</sup> /h	710 m <sup>3</sup> /h
<b>Ultimate pressure</b>	33 hPa (mbar)	33 hPa (mbar)	33 hPa (mbar)	33 hPa (mbar)
<b>Nominal motor rating</b>	15.0 kW	15.0 kW	22.0 kW	30.0 kW
<b>Weight approx. ATEX</b>	551 kg	579 kg	646 kg	724 kg

# DOLPHIN VL 0430–0750 A Total Recirculation

Liquid ring vacuum pump units



	DOLPHIN VL 0430 A Total Recirculation	DOLPHIN VL 0510 A Total Recirculation	DOLPHIN VL 0630 A Total Recirculation	DOLPHIN VL 0750 A Total Recirculation
<b>Weight approx. Safe Area</b>	474 kg	505 kg	583 kg	641 kg
<b>Dimensions (L x W x H) ATEX</b>	1645 x 946 x 1248 mm	1704 x 946 x 1248 mm	1812 x 973 x 1431 mm	1909 x 1059 x 1431 mm
<b>Dimensions (L x W x H) Safe Area</b>	1571 x 853 x 1129 mm	1585 x 894 x 1129 mm	1750 x 973 x 1144 mm	1827 x 973 x 1144 mm
<b>Gas inlet</b>	G 2"	G 2"	G 2½"	G 2½"
<b>Gas outlet</b>	R 3"	R 3"	R 4"	R 4"

**DO YOU WANT TO KNOW MORE**

Please contact us!  
sales@busch.co.nz or +64 (0)800 428 724



CONTACT FORM



CALL US NOW