

# DOLPHIN VL 0430–0750 A

## Partial Recirculation

Liquid ring vacuum pump units



Discover all advantages of  
the product series DOLPHIN  
VL

### Robust

Proven technology, reliable operation, corrosion-free stainless steel impeller, extremely high vapor and particle tolerance, part of the operating fluid is recirculated, fresh liquid introduced in sufficient quantity to maintain proper temperature

### All-in-One

Unit with base frame, operating fluid separator, control system, including inlet check valve, fresh liquid supply kit, level indicator with switches, temperature and pressure indicators and cavitation protection

### Flexible

Choice of cast iron (EN-GJL-200) or 316 grade stainless steel material housings, ATEX-certified version available (Cat. 1 (i/o) IIB, T4), operating fluids other than water possible

# DOLPHIN VL 0430–0750 A

## Partial Recirculation

Liquid ring vacuum pump units



Dimensional drawing

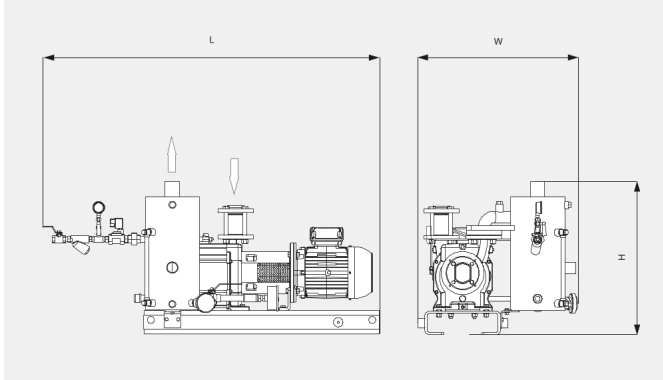

The following technical values refer to ISO 50 Hz

	DOLPHIN VL 0430 A Partial Recirculation	DOLPHIN VL 0510 A Partial Recirculation	DOLPHIN VL 0630 A Partial Recirculation	DOLPHIN VL 0750 A Partial Recirculation
<b>Nominal pumping speed</b>	340 m <sup>3</sup> /h	430 m <sup>3</sup> /h	498 m <sup>3</sup> /h	600 m <sup>3</sup> /h
<b>Ultimate pressure</b>	33 hPa (mbar)	33 hPa (mbar)	33 hPa (mbar)	33 hPa (mbar)
<b>Nominal motor rating</b>	11.0 kW	11.0 kW	15.0 kW	18.5 kW
<b>Weight approx. ATEX</b>	513 kg	543 kg	612 kg	685 kg
<b>Weight approx. Safe Area</b>	435 kg	465 kg	541 kg	593 kg
<b>Dimensions (L x W x H) ATEX</b>	1642 x 936 x 1066 mm	1702 x 936 x 1066 mm	1811 x 1045 x 1243 mm	1903 x 1045 x 1243 mm
<b>Dimensions (L x W x H) Safe Area</b>	1524 x 869 x 947 mm	1591 x 870 x 947 mm	1817 x 955 x 962 mm	1822 x 955 x 962 mm
<b>Gas inlet</b>	G 2"	G 2"	G 2½"	G 2½"
<b>Gas outlet</b>	R 3"	R 3"	R 4"	R 4"

The following technical values refer to ISO 60 Hz

	DOLPHIN VL 0430 A Partial Recirculation	DOLPHIN VL 0510 A Partial Recirculation	DOLPHIN VL 0630 A Partial Recirculation	DOLPHIN VL 0750 A Partial Recirculation
<b>Nominal pumping speed</b>	419 m <sup>3</sup> /h	515 m <sup>3</sup> /h	574 m <sup>3</sup> /h	710 m <sup>3</sup> /h
<b>Ultimate pressure</b>	33 hPa (mbar)	33 hPa (mbar)	33 hPa (mbar)	33 hPa (mbar)
<b>Nominal motor rating</b>	15.0 kW	15.0 kW	22.0 kW	30.0 kW
<b>Weight approx. ATEX</b>	513 kg	543 kg	612 kg	685 kg

# DOLPHIN VL 0430–0750 A Partial Recirculation

Liquid ring vacuum pump units



	DOLPHIN VL 0430 A Partial Recirculation	DOLPHIN VL 0510 A Partial Recirculation	DOLPHIN VL 0630 A Partial Recirculation	DOLPHIN VL 0750 A Partial Recirculation
<b>Weight approx. Safe Area</b>	435 kg	465 kg	541 kg	593 kg
<b>Dimensions (L x W x H) ATEX</b>	1642 x 936 x 1066 mm	1702 x 936 x 1066 mm	1811 x 1045 x 1243 mm	1903 x 1045 x 1243 mm
<b>Dimensions (L x W x H) Safe Area</b>	1524 x 869 x 947 mm	1591 x 870 x 947 mm	1817 x 955 x 962 mm	1822 x 955 x 962 mm
<b>Gas inlet</b>	G 2"	G 2"	G 2½"	G 2½"
<b>Gas outlet</b>	R 3"	R 3"	R 4"	R 4"

**DO YOU WANT TO KNOW MORE**

Please contact us!  
sales@busch.co.nz or +64 (0)800 428 724



CONTACT FORM



CALL US NOW