

DOLPHIN VL 0130–0320 A

Total Recirculation

Liquid ring vacuum pump units

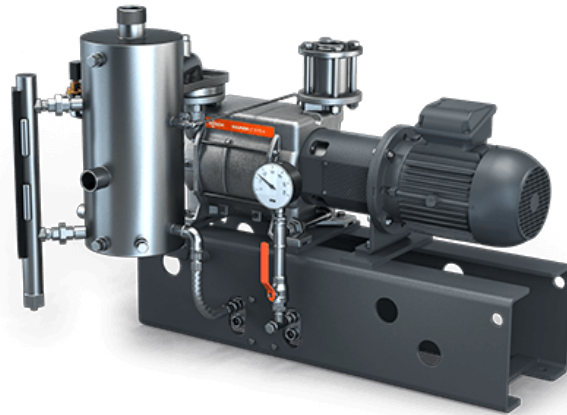

Discover all advantages of
the product series DOLPHIN
VL

Robust

Proven technology, reliable operation, corrosion-free stainless steel impeller, extremely high vapor and particle tolerance, choice of cast iron (EN-GJL-200) or 316 grade stainless steel material housings, ATEX-certified version available (Cat. 1 (i/o) IIB, T4)

All-in-One

Unit with base frame, operating fluid separator, heat exchanger, control system, including inlet check valve, fresh liquid supply kit, level indicator with switches, temperature and pressure indicators and cavitation protection

Efficient

Full recirculation of operating fluid, low operating fluid consumption, recovery of condensed vapors and process gases, isolation of cooling liquid from operating fluid, operating fluids other than water possible

DOLPHIN VL 0130–0320 A

Total Recirculation

Liquid ring vacuum pump units



Dimensional drawing

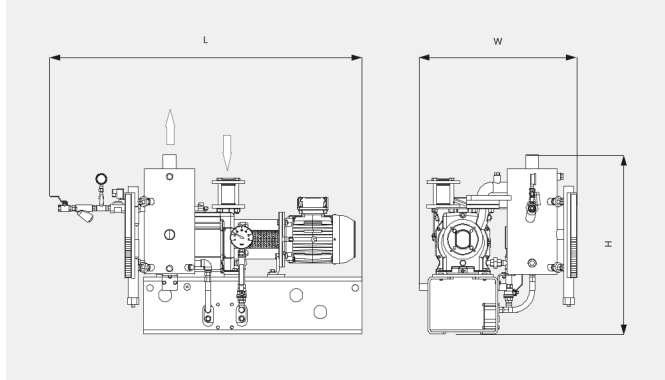

The following technical values refer to ISO 50 Hz

	DOLPHIN VL 0130 A Total Recirculation	DOLPHIN VL 0170 A Total Recirculation	DOLPHIN VL 0220 A Total Recirculation	DOLPHIN VL 0320 A Total Recirculation
Nominal pumping speed	105 m ³ /h	144 m ³ /h	203 m ³ /h	255 m ³ /h
Ultimate pressure	33 hPa (mbar)	33 hPa (mbar)	33 hPa (mbar)	33 hPa (mbar)
Nominal motor rating	3.0 kW	4.0 kW	5.5 kW	7.5 kW
Weight approx. ATEX	261 kg	277 kg	331 kg	456 kg
Weight approx. Safe Area	237 kg	247 kg	292 kg	409 kg
Dimensions (L x W x H) ATEX	1133 x 737 x 960 mm	1158 x 737 x 960 mm	1303 x 737 x 960 mm	1412 x 946 x 1248 mm
Dimensions (L x W x H) Safe Area	1133 x 730 x 819 mm	1133 x 730 x 819 mm	1233 x 730 x 819 mm	1390 x 893 x 1129 mm
Gas inlet	G 1½"	G 1½"	G 1½"	G 2"
Gas outlet	R 2"	R 2"	R 2"	R 3"

The following technical values refer to ISO 60 Hz

	DOLPHIN VL 0130 A Total Recirculation	DOLPHIN VL 0170 A Total Recirculation	DOLPHIN VL 0220 A Total Recirculation	DOLPHIN VL 0320 A Total Recirculation
Nominal pumping speed	128 m ³ /h	162 m ³ /h	230 m ³ /h	320 m ³ /h
Ultimate pressure	33 hPa (mbar)	33 hPa (mbar)	33 hPa (mbar)	33 hPa (mbar)
Nominal motor rating	4.0 kW	5.5 kW	7.5 kW	11.0 kW
Weight approx. ATEX	261 kg	277 kg	331 kg	456 kg

DOLPHIN VL 0130–0320 A Total Recirculation

Liquid ring vacuum pump units



	DOLPHIN VL 0130 A Total Recirculation	DOLPHIN VL 0170 A Total Recirculation	DOLPHIN VL 0220 A Total Recirculation	DOLPHIN VL 0320 A Total Recirculation
Weight approx. Safe Area	237 kg	247 kg	292 kg	409 kg
Dimensions (L x W x H) ATEX	1133 x 737 x 960 mm	1158 x 737 x 960 mm	1303 x 737 x 960 mm	1412 x 946 x 1248 mm
Dimensions (L x W x H) Safe Area	1133 x 730 x 819 mm	1133 x 730 x 819 mm	1233 x 730 x 819 mm	1390 x 893 x 1129 mm
Gas inlet	G 1½"	G 1½"	G 1½"	G 2"
Gas outlet	R 2"	R 2"	R 2"	R 3"

DO YOU WANT TO KNOW MORE

Please contact us!
sales@busch.co.nz or +64 (0)800 428 724



CONTACT FORM



CALL US NOW