

DOLPHIN VL 0130–0320 A

Partial Recirculation

Liquid ring vacuum pump units



Discover all advantages of
the product series DOLPHIN
VL

Robust

Proven technology, reliable operation, corrosion-free stainless steel impeller, extremely high vapor and particle tolerance, part of the operating fluid is recirculated, fresh liquid introduced in sufficient quantity to maintain proper temperature

All-in-One

Unit with base frame, operating fluid separator, control system, including inlet check valve, fresh liquid supply kit, level indicator with switches, temperature and pressure indicators and cavitation protection

Flexible

Choice of cast iron (EN-GJL-200) or 316 grade stainless steel material housings, ATEX-certified version available (Cat. 1 (i/o) IIB, T4), operating fluids other than water possible

DOLPHIN VL 0130–0320 A

Partial Recirculation

Liquid ring vacuum pump units



Dimensional drawing

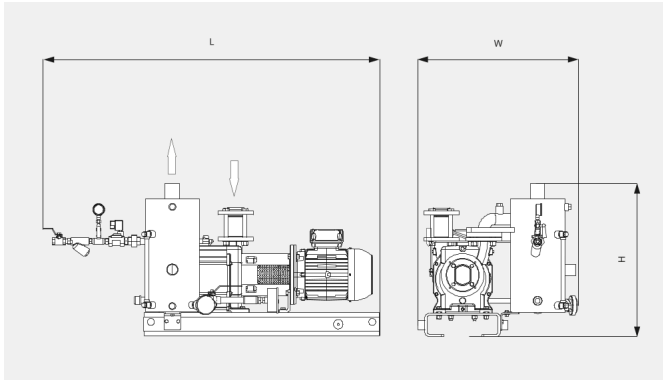

The following technical values refer to ISO 50 Hz

	DOLPHIN VL 0130 A Partial Recirculation	DOLPHIN VL 0170 A Partial Recirculation	DOLPHIN VL 0220 A Partial Recirculation	DOLPHIN VL 0320 A Partial Recirculation
Nominal pumping speed	105 m ³ /h	144 m ³ /h	203 m ³ /h	255 m ³ /h
Ultimate pressure	33 hPa (mbar)	33 hPa (mbar)	33 hPa (mbar)	33 hPa (mbar)
Nominal motor rating	3.0 kW	4.0 kW	5.5 kW	7.5 kW
Weight approx. ATEX	236 kg	248 kg	300 kg	429 kg
Weight approx. Safe Area	210 kg	220 kg	263 kg	382 kg
Dimensions (L x W x H) ATEX	1133 x 724 x 788 mm	1166 x 724 x 788 mm	1303 x 724 x 788 mm	1520 x 931 x 1064 mm
Dimensions (L x W x H) Safe Area	1133 x 704 x 647 mm	1133 x 704 x 647 mm	1231 x 704 x 647 mm	1519 x 869 x 947 mm
Gas inlet	G 1½"	G 1½"	G 1½"	G 2"
Gas outlet	R 2"	R 2"	R 2"	R 3"

The following technical values refer to ISO 60 Hz

	DOLPHIN VL 0130 A Partial Recirculation	DOLPHIN VL 0170 A Partial Recirculation	DOLPHIN VL 0220 A Partial Recirculation	DOLPHIN VL 0320 A Partial Recirculation
Nominal pumping speed	128 m ³ /h	162 m ³ /h	230 m ³ /h	320 m ³ /h
Ultimate pressure	33 hPa (mbar)	33 hPa (mbar)	33 hPa (mbar)	33 hPa (mbar)
Nominal motor rating	4.0 kW	5.5 kW	7.5 kW	11.0 kW
Weight approx. ATEX	236 kg	248 kg	300 kg	429 kg

DOLPHIN VL 0130–0320 A Partial Recirculation

Liquid ring vacuum pump units



	DOLPHIN VL 0130 A Partial Recirculation	DOLPHIN VL 0170 A Partial Recirculation	DOLPHIN VL 0220 A Partial Recirculation	DOLPHIN VL 0320 A Partial Recirculation
Weight approx. Safe Area	210 kg	220 kg	263 kg	382 kg
Dimensions (L x W x H) ATEX	1133 x 724 x 788 mm	1166 x 724 x 788 mm	1303 x 724 x 788 mm	1520 x 931 x 1064 mm
Dimensions (L x W x H) Safe Area	1133 x 704 x 647 mm	1133 x 704 x 647 mm	1231 x 704 x 647 mm	1519 x 869 x 947 mm
Gas inlet	G 1½"	G 1½"	G 1½"	G 2"
Gas outlet	R 2"	R 2"	R 2"	R 3"

DO YOU WANT TO KNOW MORE

Please contact us!
sales@busch.co.nz or +64 (0)800 428 724



CONTACT FORM



CALL US NOW