

DOLPHIN VL 0130–0320 A

Continuous Flow

Liquid ring vacuum pump units



Discover all advantages of the product series DOLPHIN VL

Robust

Proven technology, reliable operation, corrosion-free stainless steel impeller, extremely high vapor and particle tolerance, automatic solenoid valve for control of operating fluid flow from main supply

All-in-One

Unit with base frame, operating fluid separator, control system, including inlet check valve, fresh liquid supply kit, level indicator (ATEX only), temperature sensor (ATEX only) and pressure indicators and cavitation protection

Flexible

Choice of cast iron (EN-GJL-200) or 316 grade stainless steel material housings, ATEX-certified version available (Cat. 1 (i/o) IIB, T4), operating fluids other than water possible

DOLPHIN VL 0130–0320 A

Continuous Flow

Liquid ring vacuum pump units



Dimensional drawing

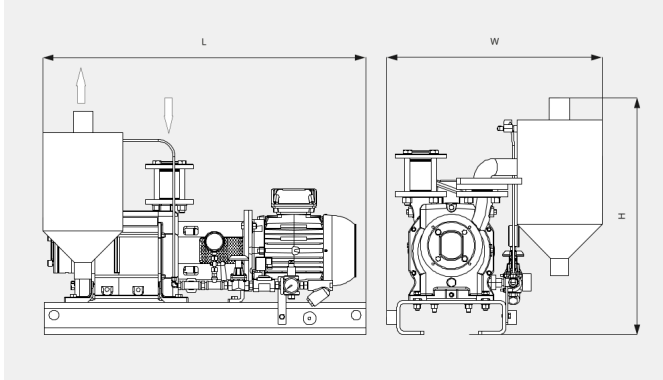

The following technical values refer to ISO 50 Hz

	DOLPHIN VL 0130 A Continuous Flow	DOLPHIN VL 0170 A Continuous Flow	DOLPHIN VL 0220 A Continuous Flow	DOLPHIN VL 0320 A Continuous Flow
Nominal pumping speed	105 m ³ /h	144 m ³ /h	203 m ³ /h	255 m ³ /h
Ultimate pressure	33 hPa (mbar)	33 hPa (mbar)	33 hPa (mbar)	33 hPa (mbar)
Nominal motor rating	3.0 kW	4.0 kW	5.5 kW	7.5 kW
Weight approx. ATEX	231 kg	248 kg	296 kg	422 kg
Weight approx. Safe Area	211 kg	221 kg	261 kg	362 kg
Dimensions (L x W x H) ATEX	1037 x 724 x 788 mm	1069 x 724 x 788 mm	1207 x 724 x 788 mm	1436 x 927 x 1067 mm
Dimensions (L x W x H) Safe Area	1005 x 632 x 687 mm	1005 x 632 x 687 mm	1103 x 632 x 687 mm	1383 x 815 x 854 mm
Gas inlet	G 1½"	G 1½"	G 1½"	G 2"
Gas outlet	R 2"	R 2"	R 2"	R 3"

The following technical values refer to ISO 60 Hz

	DOLPHIN VL 0130 A Continuous Flow	DOLPHIN VL 0170 A Continuous Flow	DOLPHIN VL 0220 A Continuous Flow	DOLPHIN VL 0320 A Continuous Flow
Nominal pumping speed	128 m ³ /h	162 m ³ /h	230 m ³ /h	320 m ³ /h
Ultimate pressure	33 hPa (mbar)	33 hPa (mbar)	33 hPa (mbar)	33 hPa (mbar)
Nominal motor rating	4.0 kW	5.5 kW	7.5 kW	11.0 kW
Weight approx. ATEX	231 kg	248 kg	296 kg	422 kg

DOLPHIN VL 0130–0320 A

Continuous Flow

Liquid ring vacuum pump units



	DOLPHIN VL 0130 A Continuous Flow	DOLPHIN VL 0170 A Continuous Flow	DOLPHIN VL 0220 A Continuous Flow	DOLPHIN VL 0320 A Continuous Flow
Weight approx. Safe Area	211 kg	221 kg	261 kg	362 kg
Dimensions (L x W x H) ATEX	1037 x 724 x 788 mm	1069 x 724 x 788 mm	1207 x 724 x 788 mm	1436 x 927 x 1067 mm
Dimensions (L x W x H) Safe Area	1005 x 632 x 687 mm	1005 x 632 x 687 mm	1103 x 632 x 687 mm	1383 x 815 x 854 mm
Gas inlet	G 1½"	G 1½"	G 1½"	G 2"
Gas outlet	R 2"	R 2"	R 2"	R 3"

DO YOU WANT TO KNOW MORE

Please contact us!
sales@busch.co.nz or +64 (0)800 428 724



CONTACT FORM



CALL US NOW