

DOLPHIN VL 0100–0270 A

Partial Recirculation

Liquid ring vacuum pump units



Discover all advantages of
the product series DOLPHIN
VL

Robust

Proven technology, reliable operation, corrosion-free stainless steel impeller, extremely high vapor and particle tolerance, part of the operating fluid is recirculated, fresh liquid introduced in sufficient quantity to maintain proper temperature

All-in-One

Unit with base frame, operating fluid separator, control system, including inlet check valve, fresh liquid supply kit, level indicator with switches, temperature and pressure indicators and cavitation protection

Flexible

Choice of cast iron (EN-GJL-200) or 316 grade stainless steel material housings, ATEX-certified version available (Cat. 1 (i/o) IIB, T4), operating fluids other than water possible

DOLPHIN VL 0100–0270 A Partial Recirculation

Liquid ring vacuum pump units



Dimensional drawing

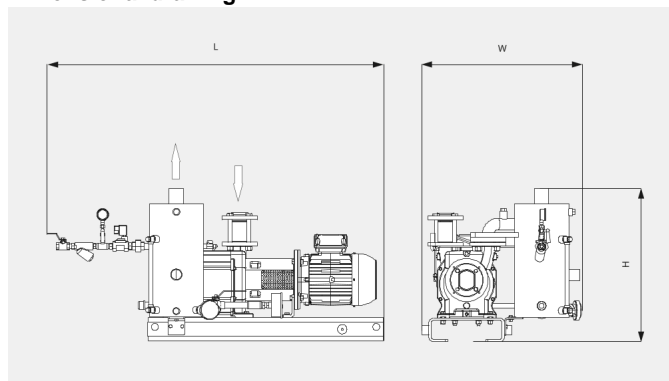

The following technical values refer to ISO 50 Hz

	DOLPHIN VL 0100 A Partial Recirculation	DOLPHIN VL 0180 A Partial Recirculation	DOLPHIN VL 0270 A Partial Recirculation
Nominal pumping speed	82 m ³ /h	144 m ³ /h	220 m ³ /h
Ultimate pressure	130 hPa (mbar)	130 hPa (mbar)	130 hPa (mbar)
Nominal motor rating	2.2 kW	4.0 kW	5.5 kW
Weight approx. ATEX	205 kg	229 kg	269 kg
Weight approx. Safe Area	183 kg	187 kg	230 kg
Dimensions (L x W x H) ATEX	1020 x 724 x 788 mm	1090 x 724 x 788 mm	1205 x 724 x 788 mm
Dimensions (L x W x H) Safe Area	983 x 704 x 647 mm	1028 x 704 x 647 mm	1136 x 704 x 647 mm
Gas inlet	G 1½"	G 1½"	G 1½"
Gas outlet	R 2"	R 2"	R 2"

The following technical values refer to ISO 60 Hz

	DOLPHIN VL 0100 A Partial Recirculation	DOLPHIN VL 0180 A Partial Recirculation	DOLPHIN VL 0270 A Partial Recirculation
Nominal pumping speed	98 m ³ /h	180 m ³ /h	267 m ³ /h
Ultimate pressure	130 hPa (mbar)	130 hPa (mbar)	130 hPa (mbar)
Nominal motor rating	3.0 kW	5.5 kW	7.5 kW
Weight approx. ATEX	205 kg	229 kg	269 kg
Weight approx. Safe Area	183 kg	187 kg	230 kg

DOLPHIN VL 0100–0270 A Partial Recirculation

Liquid ring vacuum pump units



	DOLPHIN VL 0100 A Partial Recirculation	DOLPHIN VL 0180 A Partial Recirculation	DOLPHIN VL 0270 A Partial Recirculation
Dimensions (L x W x H) ATEX	1020 x 724 x 788 mm	1090 x 724 x 788 mm	1205 x 724 x 788 mm
Dimensions (L x W x H) Safe Area	983 x 704 x 647 mm	1028 x 704 x 647 mm	1136 x 704 x 647 mm
Gas inlet	G 1½"	G 1½"	G 1½"
Gas outlet	R 2"	R 2"	R 2"

DO YOU WANT TO KNOW MORE

Please contact us!
sales@busch.co.nz or +64 (0)800 428 724



CONTACT FORM



CALL US NOW