

# DOLPHIN LX 0260–0430 C

Liquid ring vacuum pumps



Discover all advantages of the product series DOLPHIN LX

## Robust

Proven technology, reliable operation, extremely high particle and vapor tolerance, corrosion-free stainless steel impeller

## Compact

Directly flanged motor, no base frame required

## Flexible

Choice of cast iron (EN-GJL-200) or 316 grade stainless steel material housings, ATEX-certified version available (Cat. 2 (i) IIB, T4), operating fluids other than water possible

### Accessories

- Partial or total recirculation systems
- Liquid separator
- Cavitation protection
- Heat exchanger
- Gas ejector
- Wide selection of motors
- Non-return valves
- Vacuum relief valves
- Different operating fluids possible

# DOLPHIN LX 0260–0430 C

Liquid ring vacuum pumps



VACUUM SOLUTIONS

## Dimensional drawing

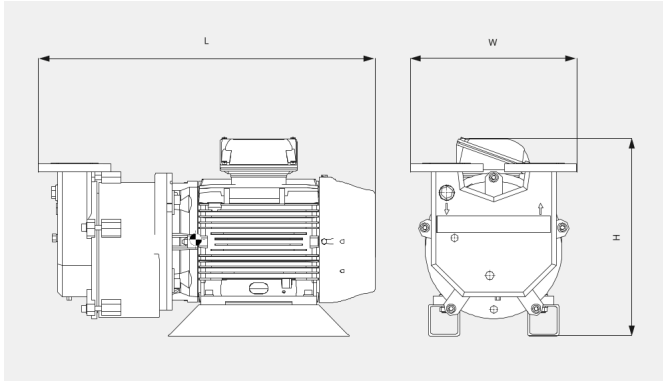

## Pumping speed

Dry air at 20 °C. Operating fluid water 15°C. Tolerance: - 10%, in accordance with HEI and Pneurop 6612

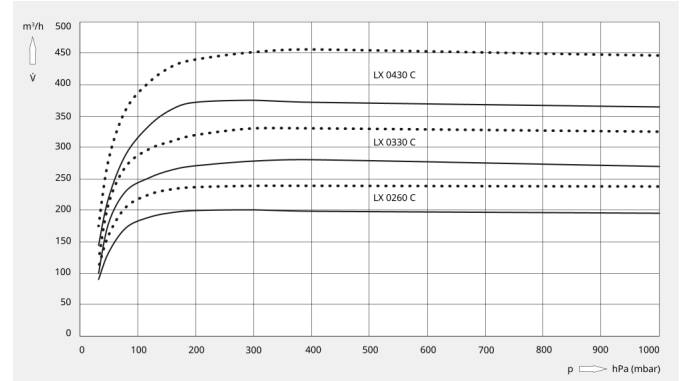

The following technical values refer to ISO 50 Hz

	DOLPHIN LX 0260 C	DOLPHIN LX 0330 C	DOLPHIN LX 0430 C
Nominal pumping speed	200 m³/h	280 m³/h	375 m³/h
Ultimate pressure	33 hPa (mbar)	33 hPa (mbar)	33 hPa (mbar)
Nominal motor rating	5.5 kW	7.5 kW	11.0 kW
Nominal motor speed	1450 min <sup>-1</sup>	1450 min <sup>-1</sup>	1450 min <sup>-1</sup>
Noise level (ISO 2151)	72 dB(A)	72 dB(A)	72 dB(A)
Weight approx.	135 kg	147 kg	227 kg
Dimensions (L x W x H)	635 x 365 x 402 mm	706 x 365 x 402 mm	818 x 425 x 506 mm
Gas inlet	DN 50 PN16	DN 50 PN16	DN 65 PN16
Gas outlet	DN 50 PN16	DN 50 PN16	DN 65 PN16

The following technical values refer to ISO 60 Hz

	DOLPHIN LX 0260 C	DOLPHIN LX 0330 C	DOLPHIN LX 0430 C
Nominal pumping speed	239 m³/h	330 m³/h	455 m³/h
Ultimate pressure	33 hPa (mbar)	33 hPa (mbar)	33 hPa (mbar)
Nominal motor rating	7.5 kW	11.0 kW	15.0 kW
Nominal motor speed	1750 min <sup>-1</sup>	1750 min <sup>-1</sup>	1750 min <sup>-1</sup>
Noise level (ISO 2151)	72 dB(A)	72 dB(A)	72 dB(A)

# DOLPHIN LX 0260–0430 C

Liquid ring vacuum pumps



VACUUM SOLUTIONS

	DOLPHIN LX 0260 C	DOLPHIN LX 0330 C	DOLPHIN LX 0430 C
<b>Weight approx.</b>	145 kg	198 kg	247 kg
<b>Dimensions (L x W x H)</b>	635 x 365 x 402 mm	706 x 365 x 402 mm	818 x 425 x 506 mm
<b>Gas inlet</b>	DN 50 PN16	DN 50 PN16	DN 65 PN16
<b>Gas outlet</b>	DN 50 PN16	DN 50 PN16	DN 65 PN16

**DO YOU WANT TO KNOW MORE**

Please contact us!  
sales@busch.co.nz or +64 (0)800 428 724



CONTACT FORM



CALL US NOW