

# DOLPHIN LX 0110–0180 C

Liquid ring vacuum pumps



Discover all advantages of the product series DOLPHIN LX

## Robust

Proven technology, reliable operation, extremely high particle and vapor tolerance, corrosion-free stainless steel impeller

## Compact

Directly flanged motor, no base frame required

## Flexible

Choice of cast iron (EN-GJL-200) or 316 grade stainless steel material housings, ATEX-certified version available (Cat. 2 (i) IIB, T4), operating fluids other than water possible

### Accessories

- Partial or total recirculation systems
- Liquid separator
- Cavitation protection
- Heat exchanger
- Gas ejector
- Wide selection of motors
- Non-return valves
- Vacuum relief valves
- Different operating fluids possible

# DOLPHIN LX 0110–0180 C

Liquid ring vacuum pumps



## Dimensional drawing

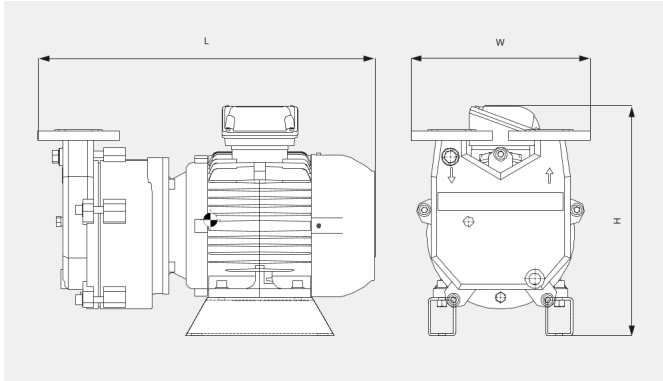

## Pumping speed

Dry air at 20 °C. Operating fluid water 15°C. Tolerance: - 10%, in accordance with HEI and Pneurop 6612

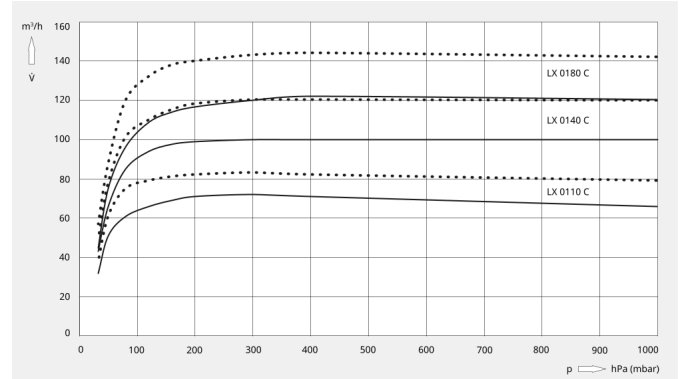

The following technical values refer to ISO 50 Hz

	DOLPHIN LX 0110 C	DOLPHIN LX 0140 C	DOLPHIN LX 0180 C
Nominal pumping speed	72 m³/h	100 m³/h	122 m³/h
Ultimate pressure	33 hPa (mbar)	33 hPa (mbar)	33 hPa (mbar)
Nominal motor rating	2.2 kW	3.0 kW	4.0 kW
Nominal motor speed	1450 min <sup>-1</sup>	1450 min <sup>-1</sup>	1450 min <sup>-1</sup>
Noise level (ISO 2151)	70 dB(A)	70 dB(A)	70 dB(A)
Weight approx.	76 kg	86 kg	95 kg
Dimensions (L x W x H)	517 x 330 x 347 mm	568 x 330 x 347 mm	564 x 330 x 374 mm
Gas inlet	DN 40 PN 16	DN 40 PN 16	DN 40 PN 16
Gas outlet	DN 40 PN 16	DN 40 PN 16	DN 40 PN 16

The following technical values refer to ISO 60 Hz

	DOLPHIN LX 0110 C	DOLPHIN LX 0140 C	DOLPHIN LX 0180 C
Nominal pumping speed	83 m³/h	120 m³/h	144 m³/h
Ultimate pressure	33 hPa (mbar)	33 hPa (mbar)	33 hPa (mbar)
Nominal motor rating	3.0 kW	4.0 kW	5.5 kW
Nominal motor speed	1750 min <sup>-1</sup>	1750 min <sup>-1</sup>	1750 min <sup>-1</sup>
Noise level (ISO 2151)	70 dB(A)	70 dB(A)	70 dB(A)

# DOLPHIN LX 0110–0180 C

Liquid ring vacuum pumps



VACUUM SOLUTIONS

	DOLPHIN LX 0110 C	DOLPHIN LX 0140 C	DOLPHIN LX 0180 C
<b>Weight approx.</b>	83 kg	92 kg	112 kg
<b>Dimensions (L x W x H)</b>	517 x 330 x 347 mm	568 x 330 x 347 mm	564 x 330 x 374 mm
<b>Gas inlet</b>	DN 40 PN 16	DN 40 PN 16	DN 40 PN 16
<b>Gas outlet</b>	DN 40 PN 16	DN 40 PN 16	DN 40 PN 16

**DO YOU WANT TO KNOW MORE**

Please contact us!  
sales@busch.co.nz or +64 (0)800 428 724



CONTACT FORM



CALL US NOW