

# DOLPHIN LB 0857–1757 A

Liquid ring vacuum pumps



VACUUM SOLUTIONS



Discover all advantages of the product series DOLPHIN LB

## Robust

Proven technology, durable two-stage construction

## Reliable

Extremely high vapor and particle tolerance

## Flexible

Wide range of construction materials, including cast iron (EN-GJL-200), many grades of stainless steel and even titanium, ATEX-certified version available (Cat 1(i)/2(o) IIC T5), operating fluids other than water possible, operation as compressor possible

### Accessories

- Partial or total recirculation systems
- Liquid separator
- Cavitation protection
- Heat exchanger
- Gas ejector
- Wide selection of motors
- Non-return valves
- Vacuum relief valves

# DOLPHIN LB 0857–1757 A

Liquid ring vacuum pumps



## Dimensional drawing

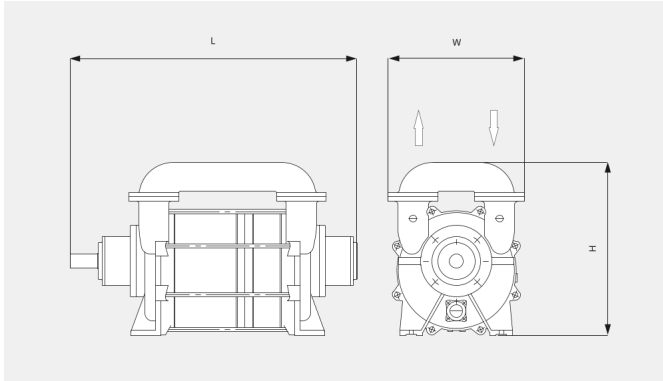

## Pumping speed

Dry air at 20 °C. Tolerance: - 10%, in accordance with HEI and Pneurop 6612

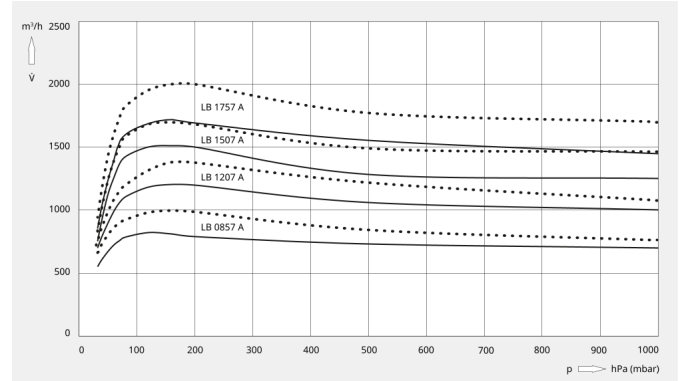

The following technical values refer to ISO 50 Hz

	DOLPHIN LB 0857 A	DOLPHIN LB 1207 A	DOLPHIN LB 1507 A	DOLPHIN LB 1757 A
<b>Nominal pumping speed</b>	850 m³/h	1200 m³/h	1500 m³/h	1750 m³/h
<b>Ultimate pressure</b>	33 hPa (mbar)	33 hPa (mbar)	33 hPa (mbar)	33 hPa (mbar)
<b>Max. overpressure</b>	2 bar(g)	2 bar(g)	2 bar(g)	2 bar(g)
<b>Nominal motor rating</b>	30 kW	37 kW	45 kW	75 kW
<b>Nominal motor speed</b>	960 min <sup>-1</sup>	960 min <sup>-1</sup>	960 min <sup>-1</sup>	960 min <sup>-1</sup>
<b>Noise level (ISO 2151)</b>	76 dB(A)	76 dB(A)	76 dB(A)	76 dB(A)
<b>Weight approx.</b>	510 kg	600 kg	685 kg	770 kg
<b>Dimensions (L x W x H)</b>	1096 x 610 x 750 mm	1246 x 610 x 750 mm	1346 x 610 x 750 mm	1496 x 610 x 750 mm
<b>Gas inlet</b>	DN 100 PN 10	DN 100 PN 10	DN 100 PN 10	DN 100 PN 10
<b>Gas outlet</b>	DN 100 PN 10	DN 100 PN 10	DN 100 PN 10	DN 100 PN 10

The following technical values refer to ISO 60 Hz

	DOLPHIN LB 0857 A	DOLPHIN LB 1207 A	DOLPHIN LB 1507 A	DOLPHIN LB 1757 A
<b>Nominal pumping speed</b>	1000 m³/h	1380 m³/h	1690 m³/h	2000 m³/h
<b>Ultimate pressure</b>	33 hPa (mbar)	33 hPa (mbar)	33 hPa (mbar)	33 hPa (mbar)
<b>Max. overpressure</b>	2 bar(g)	2 bar(g)	2 bar(g)	2 bar(g)

# DOLPHIN LB 0857–1757 A

Liquid ring vacuum pumps



	DOLPHIN LB 0857 A	DOLPHIN LB 1207 A	DOLPHIN LB 1507 A	DOLPHIN LB 1757 A
<b>Nominal motor rating</b>	37 kW	55 kW	75 kW	90 kW
<b>Nominal motor speed</b>	1150 min <sup>-1</sup>	1150 min <sup>-1</sup>	1150 min <sup>-1</sup>	1150 min <sup>-1</sup>
<b>Noise level (ISO 2151)</b>	77 dB(A)	77 dB(A)	77 dB(A)	77 dB(A)
<b>Weight approx.</b>	510 kg	600 kg	685 kg	770 kg
<b>Dimensions (L x W x H)</b>	1282 x 610 x 750 mm	1432 x 610 x 750 mm	1532 x 610 x 750 mm	1682 x 610 x 750 mm
<b>Gas inlet</b>	DN 100 PN 10	DN 100 PN 10	DN 100 PN 10	DN 100 PN 10
<b>Gas outlet</b>	DN 100 PN 10	DN 100 PN 10	DN 100 PN 10	DN 100 PN 10

**DO YOU WANT TO KNOW MORE**

Please contact us!  
sales@busch.co.nz or +64 (0)800 428 724



CONTACT FORM



CALL US NOW