

DOLPHIN LB 0265–0425 A

Liquid ring vacuum pumps



VACUUM SOLUTIONS



Discover all advantages of
the product series DOLPHIN
LB

Robust

Proven technology, durable two-stage construction

Reliable

Extremely high vapor and particle tolerance

Flexible

Wide range of construction materials, including cast iron (EN-GJL-200), many grades of stainless steel and even titanium, ATEX-certified version available (Cat 1(i)/2(o) IIC T5), operating fluids other than water possible, operation as compressor possible

Accessories

- Partial or total recirculation systems
- Liquid separator
- Cavitation protection
- Heat exchanger
- Gas ejector
- Wide selection of motors
- Non-return valves
- Vacuum relief valves

DOLPHIN LB 0265–0425 A

Liquid ring vacuum pumps



Dimensional drawing

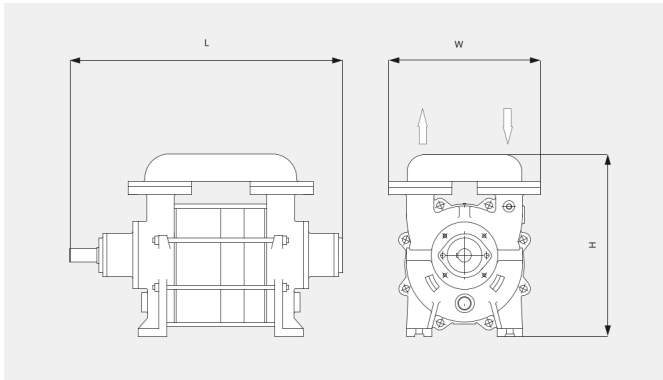

Pumping speed

Air at 20 °C. Tolerance: ± 10%

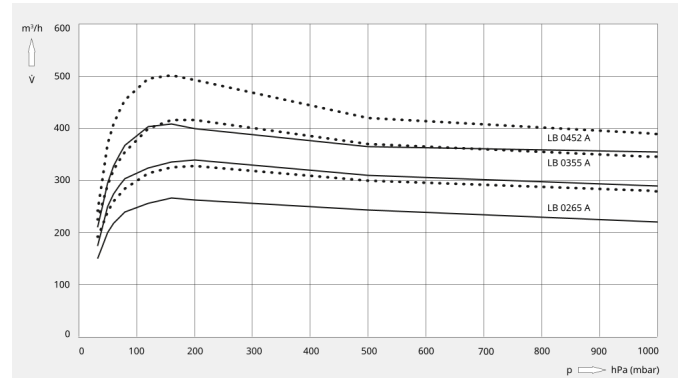

The following technical values refer to ISO 50 Hz

	DOLPHIN LB 0265 A	DOLPHIN LB 0355 A	DOLPHIN LB 0425 A
Nominal pumping speed	260 m³/h	350 m³/h	420 m³/h
Ultimate pressure	33 hPa (mbar)	33 hPa (mbar)	33 hPa (mbar)
Max. overpressure	2 bar(g)	2 bar(g)	2 bar(g)
Nominal motor rating	9.2 kW	11 kW	15 kW
Nominal motor speed	1450 min ⁻¹	1450 min ⁻¹	1450 min ⁻¹
Noise level (ISO 2151)	75 dB(A)	75 dB(A)	75 dB(A)
Weight approx.	165 kg	183 kg	194 kg
Dimensions (L x W x H)	707 x 300 x 472 mm	767 x 300 x 472 mm	807 x 300 x 472 mm
Gas inlet	DN 50 PN 10	DN 50 PN 10	DN 50 PN 10
Gas outlet	DN 50 PN 10	DN 50 PN 10	DN 50 PN 10

The following technical values refer to ISO 60 Hz

	DOLPHIN LB 0265 A	DOLPHIN LB 0355 A	DOLPHIN LB 0425 A
Nominal pumping speed	325 m³/h	400 m³/h	500 m³/h
Ultimate pressure	33 hPa (mbar)	33 hPa (mbar)	33 hPa (mbar)
Max. overpressure	2 bar(g)	2 bar(g)	2 bar(g)
Nominal motor rating	11 kW	15 kW	15 kW

DOLPHIN LB 0265–0425 A

Liquid ring vacuum pumps



	DOLPHIN LB 0265 A	DOLPHIN LB 0355 A	DOLPHIN LB 0425 A
Nominal motor speed	1750 min ⁻¹	1750 min ⁻¹	1750 min ⁻¹
Noise level (ISO 2151)	75 dB(A)	75 dB(A)	75 dB(A)
Weight approx.	165 kg	183 kg	194 kg
Dimensions (L x W x H)	898 x 300 x 472 mm	958 x 300 x 472 mm	998 x 300 x 472 mm
Gas inlet	DN 50 PN 10	DN 50 PN 10	DN 50 PN 10
Gas outlet	DN 50 PN 10	DN 50 PN 10	DN 50 PN 10

DO YOU WANT TO KNOW MORE

Please contact us!
sales@busch.co.nz or +64 (0)800 428 724



CONTACT FORM



CALL US NOW