

DOLPHIN LA 1908–2808 A

Liquid ring vacuum pumps

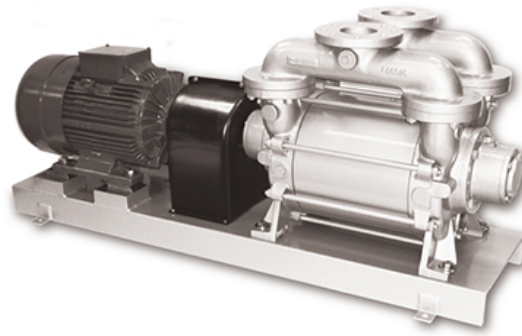

Discover all advantages of the product series DOLPHIN LA

Robust

Proven technology, durable single-stage construction

Reliable

Extremely high vapor and particle tolerance

Flexible

Wide range of construction materials, including cast iron (EN-GJL-200), many grades of stainless steel and even titanium, ATEX-certified version available (Cat 1(i)/2(o) IIC T5), different operating fluids possible, operation as compressor possible

Accessories

- Partial or total recirculation systems
- Liquid separator
- Cavitation protection
- Heat exchanger
- Gas ejector
- Wide selection of motors
- Non-return valves
- Vacuum relief valves

DOLPHIN LA 1908–2808 A

Liquid ring vacuum pumps



VACUUM SOLUTIONS

Dimensional drawing

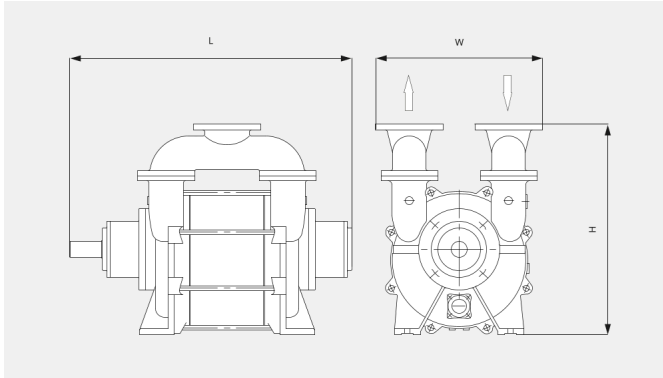

Pumping speed

Air at 20 °C. Tolerance: ± 10%

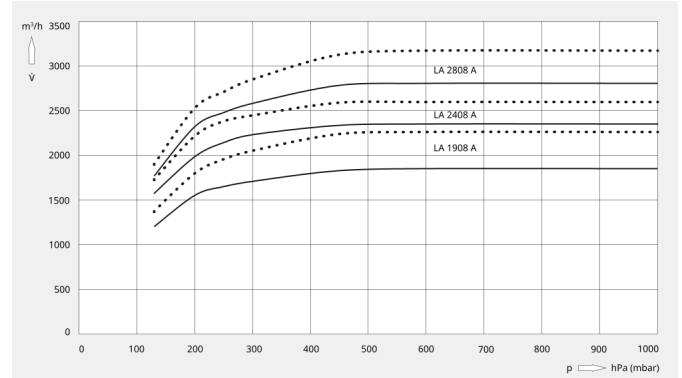

The following technical values refer to ISO 50 Hz

	DOLPHIN LA 1908 A	DOLPHIN LA 2408 A	DOLPHIN LA 2808 A
Nominal pumping speed	1900 m³/h	2400 m³/h	2800 m³/h
Ultimate pressure	130 hPa (mbar)	130 hPa (mbar)	130 hPa (mbar)
Max. overpressure	2 bar(g)	2 bar(g)	2 bar(g)
Nominal motor rating	75 kW	75 kW	90 kW
Nominal motor speed	735 min ⁻¹	735 min ⁻¹	735 min ⁻¹
Noise level (ISO 2151)	79 dB(A)	79 dB(A)	79 dB(A)
Weight approx.	1445 kg	1610 kg	1770 kg
Dimensions (L x W x H)	1418 x 650 x 1060 mm	1518 x 650 x 1060 mm	1618 x 650 x 1060 mm
Gas inlet	DN 200 PN 10	DN 200 PN 10	DN 200 PN 10
Gas outlet	DN 200 PN 10	DN 200 PN 10	DN 200 PN 10

The following technical values refer to ISO 60 Hz

	DOLPHIN LA 1908 A	DOLPHIN LA 2408 A	DOLPHIN LA 2808 A
Nominal pumping speed	2250 m³/h	2600 m³/h	3150 m³/h
Ultimate pressure	130 hPa (mbar)	130 hPa (mbar)	130 hPa (mbar)
Max. overpressure	2 bar(g)	2 bar(g)	2 bar(g)
Nominal motor rating	90 kW	110 kW	150 kW

DOLPHIN LA 1908–2808 A

Liquid ring vacuum pumps



	DOLPHIN LA 1908 A	DOLPHIN LA 2408 A	DOLPHIN LA 2808 A
Nominal motor speed	880 min ⁻¹	880 min ⁻¹	880 min ⁻¹
Noise level (ISO 2151)	79 dB(A)	79 dB(A)	79 dB(A)
Weight approx.	1445 kg	1610 kg	1770 kg
Dimensions (L x W x H)	1698 x 650 x 1060 mm	1798 x 650 x 1060 mm	1898 x 650 x 1060 mm
Gas inlet	DN 200 PN 10	DN 200 PN 10	DN 200 PN 10
Gas outlet	DN 200 PN 10	DN 200 PN 10	DN 200 PN 10

DO YOU WANT TO KNOW MORE

Please contact us!
sales@busch.co.nz or +64 (0)800 428 724



CONTACT FORM



CALL US NOW