

DOLPHIN LA 0224–0475 A

Liquid ring vacuum pumps



VACUUM SOLUTIONS



Discover all advantages of
the product series DOLPHIN
LA

Robust

Proven technology, durable single-stage construction

Reliable

Extremely high vapor and particle tolerance

Flexible

Wide range of construction materials, including cast iron (EN-GJL-200), many grades of stainless steel and even titanium, ATEX-certified version available (Cat 1(i)/2(o) IIC T5), different operating fluids possible, operation as compressor possible

Accessories

- Partial or total recirculation systems
- Liquid separator
- Cavitation protection
- Heat exchanger
- Gas ejector
- Wide selection of motors
- Non-return valves
- Vacuum relief valves

DOLPHIN LA 0224–0475 A

Liquid ring vacuum pumps



Dimensional drawing

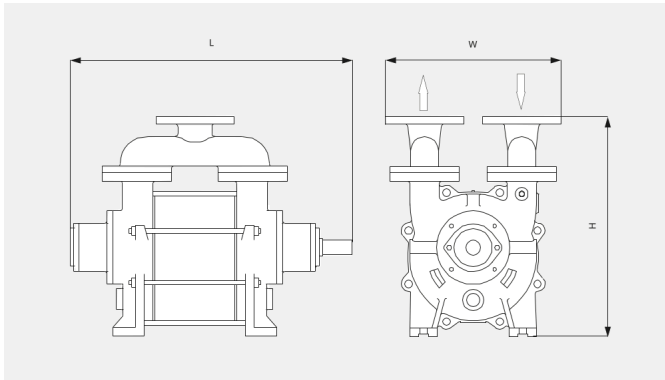

Pumping speed

Air at 20 °C. Tolerance: ± 10%

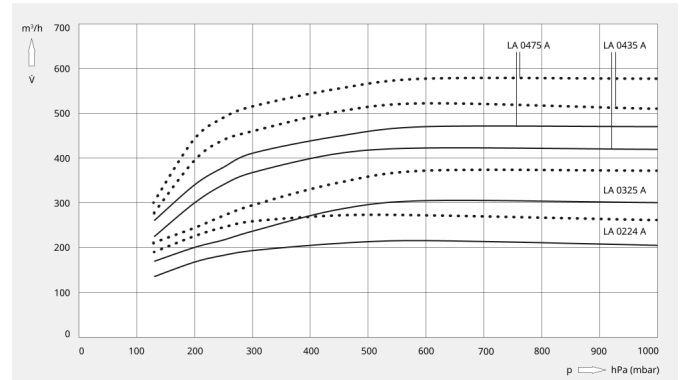

The following technical values refer to ISO 50 Hz

	DOLPHIN LA 0224 A	DOLPHIN LA 0325 A	DOLPHIN LA 0435 A	DOLPHIN LA 0475 A
Nominal pumping speed	220 m³/h	320 m³/h	430 m³/h	470 m³/h
Ultimate pressure	130 hPa (mbar)	150 hPa (mbar)	150 hPa (mbar)	130 hPa (mbar)
Max. overpressure	2 bar(g)	2 bar(g)	2 bar(g)	2 bar(g)
Nominal motor rating	5.5 kW	11 kW	11 kW	18.5 kW
Nominal motor speed	1450 min ⁻¹	1450 min ⁻¹	1450 min ⁻¹	1450 min ⁻¹
Noise level (ISO 2151)	72 dB(A)	75 dB(A)	75 dB(A)	74 dB(A)
Weight approx.	94 kg	159 kg	159 kg	210 kg
Dimensions (L x W x H)	547 x 270 x 450 mm	626 x 300 x 387 mm	667 x 300 x 520 mm	797 x 300 x 520 mm
Gas inlet	DN 50 PN 10	DN 50 PN 10	DN 65 PN 10	DN 65 PN 10
Gas outlet	DN 50 PN 10	DN 50 PN 10	DN 65 PN 10	DN 65 PN 10

The following technical values refer to ISO 60 Hz

	DOLPHIN LA 0224 A	DOLPHIN LA 0325 A	DOLPHIN LA 0435 A	DOLPHIN LA 0475 A
Nominal pumping speed	270 m³/h	350 m³/h	500 m³/h	570 m³/h
Ultimate pressure	130 hPa (mbar)	150 hPa (mbar)	150 hPa (mbar)	130 hPa (mbar)
Max. overpressure	2 bar(g)	2 bar(g)	2 bar(g)	2 bar(g)
Nominal motor rating	7.5 kW	15 kW	15 kW	22 kW

DOLPHIN LA 0224–0475 A

Liquid ring vacuum pumps



	DOLPHIN LA 0224 A	DOLPHIN LA 0325 A	DOLPHIN LA 0435 A	DOLPHIN LA 0475 A
Nominal motor speed	1750 min ⁻¹	1750 min ⁻¹	1750 min ⁻¹	1750 min ⁻¹
Noise level (ISO 2151)	72 dB(A)	75 dB(A)	75 dB(A)	74 dB(A)
Weight approx.	94 kg	159 kg	159 kg	210 kg
Dimensions (L x W x H)	713 x 270 x 450 mm	817 x 300 x 387 mm	857 x 300 x 520 mm	787 x 300 x 520 mm
Gas inlet	DN 50 PN 10	DN 50 PN 10	DN 65 PN 10	DN 65 PN 10
Gas outlet	DN 50 PN 10	DN 50 PN 10	DN 65 PN 10	DN 65 PN 10

DO YOU WANT TO KNOW MORE

Please contact us!
sales@busch.co.nz or +64 (0)800 428 724



CONTACT FORM



CALL US NOW