

# COBRA NC 0100–0300 B

Dry screw vacuum pumps



Discover all advantages of  
the product series COBRA  
NC

## High performance

Advanced screw design, patented self-balancing screws, perfectly suited for chemical processes, distillation and vacuum drying

## Efficient

Low cost of ownership, minimal maintenance, long service intervals, high uptime, efficient water cooling

## Flexible

Air cooling, various sealing and coating configurations as well as ATEX-certified versions available

### Accessories

- Purge gas system
- Sealing gas supply
- Dilution gas supply
- Connection adapter to connect ISO or ASME flanges
- Non-return valve
- Exhaust gas silencer
- Air cooling
- Various sealing and coating configurations
- ATEX-certified versions available

# COBRA NC 0100–0300 B

Dry screw vacuum pumps



## Dimensional drawing

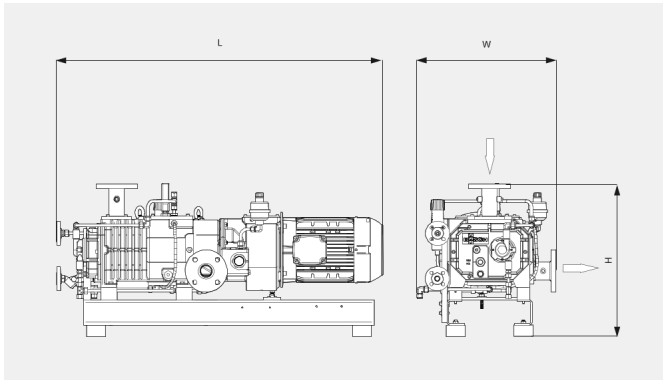

## Pumping speed

Air at 20 °C. Tolerance: ± 10%

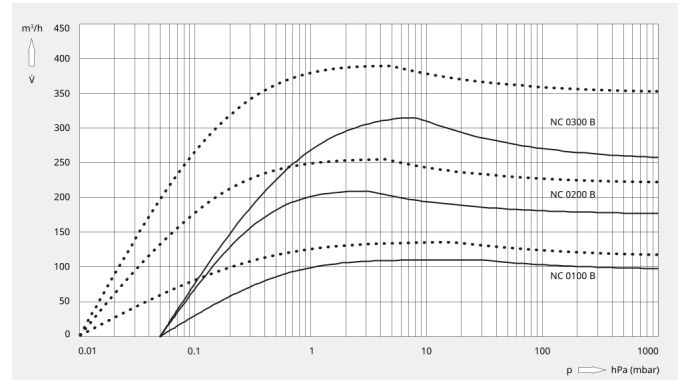

The following technical values refer to ISO 50 Hz

	COBRA NC 0100 B	COBRA NC 0200 B	COBRA NC 0300 B
<b>Pumping speed</b>	110 m³/h	220 m³/h	320 m³/h
<b>Ultimate pressure</b>	≤ 0.05 hPa (mbar)	≤ 0.05 hPa (mbar)	≤ 0.05 hPa (mbar)
<b>Nominal motor rating</b>	3.5 kW	6.0 kW	7.5 kW
<b>Nominal motor speed</b>	3000 min <sup>-1</sup>	3000 min <sup>-1</sup>	3000 min <sup>-1</sup>
<b>Noise level (ISO 2151)</b>	≤ 70 dB(A)	≤ 71 dB(A)	≤ 72 dB(A)
<b>Weight approx.</b>	300 kg	350 kg	400 kg
<b>Dimensions (L x W x H)</b>	1127 x 520 x 595 mm	1264 x 520 x 607 mm	1334 x 520 x 607 mm
<b>Gas inlet</b>	DN 40 PN 16	DN 50 PN 16	DN 50 PN 16
<b>Gas outlet</b>	DN 40 PN 16	DN 50 PN 16	DN 50 PN 16

The following technical values refer to ISO 60 Hz

	COBRA NC 0100 B	COBRA NC 0200 B	COBRA NC 0300 B
<b>Pumping speed</b>	130 m³/h	265 m³/h	385 m³/h
<b>Ultimate pressure</b>	≤ 0.01 hPa (mbar)	≤ 0.01 hPa (mbar)	≤ 0.01 hPa (mbar)
<b>Nominal motor rating</b>	4.8 kW	7.6 kW	9.5 kW
<b>Nominal motor speed</b>	3600 min <sup>-1</sup>	3600 min <sup>-1</sup>	3600 min <sup>-1</sup>
<b>Noise level (ISO 2151)</b>	≤ 74 dB(A)	≤ 76 dB(A)	≤ 77 dB(A)

# COBRA NC 0100–0300 B

Dry screw vacuum pumps



	COBRA NC 0100 B	COBRA NC 0200 B	COBRA NC 0300 B
<b>Weight approx.</b>	300 kg	350 kg	400 kg
<b>Dimensions (L x W x H)</b>	1127 x 520 x 595 mm	1264 x 520 x 607 mm	1334 x 520 x 607 mm
<b>Gas inlet</b>	DN 40 PN 16	DN 50 PN 16	DN 50 PN 16
<b>Gas outlet</b>	DN 40 PN 16	DN 50 PN 16	DN 50 PN 16

**DO YOU WANT TO KNOW MORE**

Please contact us!  
sales@busch.co.nz or +64 (0)800 428 724



CONTACT FORM



CALL US NOW