

MINK MM 1104/1102 CVM

Tørre klovakuumpumper



VACUUM SOLUTIONS



Pålitelig

Mer enn 50 000 MINK-vakuumpumper i drift i melkeroboter og -anlegg, utprøvd klovakuumteknologi, ingen driftsvæsker, nesten vedlikeholdsfri, lang levetid

Effektiv

Opptil 25 % energibesparelser sammenlignet med konvensjonelle vakuumgeneratorer i bruk til melkeroboter og -anlegg

Fleksibel

Stort frekvensomfang fra 10 til 60 Hz

MINK MM 1104/1102 CVM

Tørre klovakuumpumper



VACUUM SOLUTIONS

Målskisse

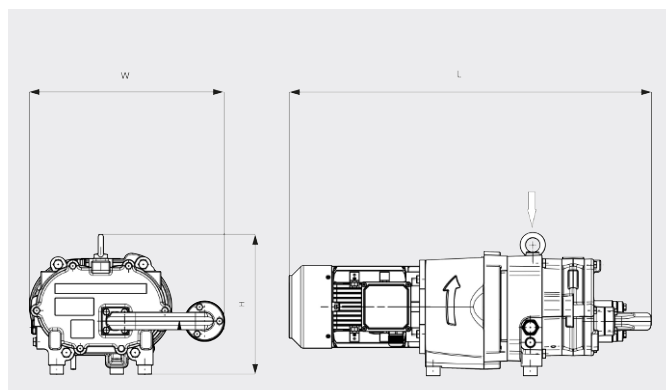

Pumpekapasitet

Luft ved 20 °C. Toleranse: ±10 %

— 50 Hz 60 Hz

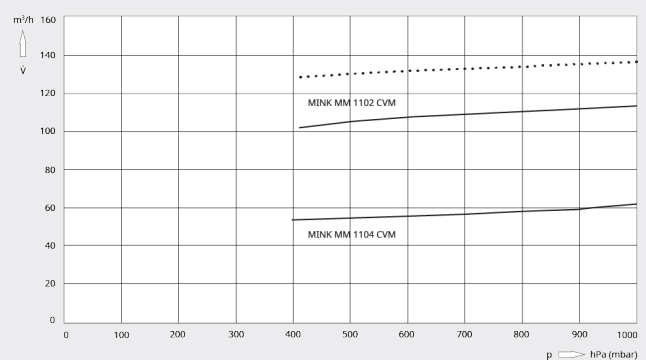

	MM 1104 CVM	MM 1102 CVM	MM 1102 CVM
Nominell pumpekapasitet	62 m ³ /t (50 Hz)	110 m ³ /t (50 Hz)	110 / 135 m ³ /t (50/60 Hz)
Sluttrykk	400 hPa (mbar) (50 Hz)	400 hPa (mbar) (50 Hz)	400 hPa (mbar) (50/60 Hz)
Nominell motoreffekt	1,3 kW (50 Hz)	2,2 kW (50 Hz)	3,0 / 3,4 kW (50/60 Hz)
Nominell motorhastighet	1500 min ⁻¹ (50 Hz)	3000 min ⁻¹ (50 Hz)	3000 / 3600 min ⁻¹ (50/60 Hz)
Støynivå (ISO 2151)	72 dB(A) (50 Hz)	70 dB(A) (50 Hz)	73 / 77 dB(A) (50/60 Hz)
Oljevolum	0,5 l	0,5 l	0,5 l
Vekt ca.	78 kg *	140 kg *	140 kg *
Mål (L x W x H)	771 x 428 x 306 mm	898 x 339 x 301 mm	898 x 339 x 301 mm

VIL DU VITE MER?

Ta kontakt med oss!
post@busch.no eller +47 64 98 98 50



KONTAKTSKJEMA



RING NÅ