

# SECO SV 1063-1100 B/C

Tørtløpende lamellvakuumpumper



## Kompakt

Direktdriftkonstruksjon

## Pålitelig

Robust konstruksjon, gjennomprøvd ytelse, selvsmørende lameller, ingen driftsvæsker

## Høy ytelse

Høy oppetid, lameller med høy ytelse

Tilbehør, reservedeler og tilvalg

- Innløpsfilter
- Vakuumreguleringsventil
- Vakuumavlastingsventil for SV 1063/1080 B
- Tilbakeslagsventil (innløp)
- Slangenippel

# SECO SV 1063-1100 B/C

Tørtløpende lamellvakuumpumper



## Dimensjonstegning

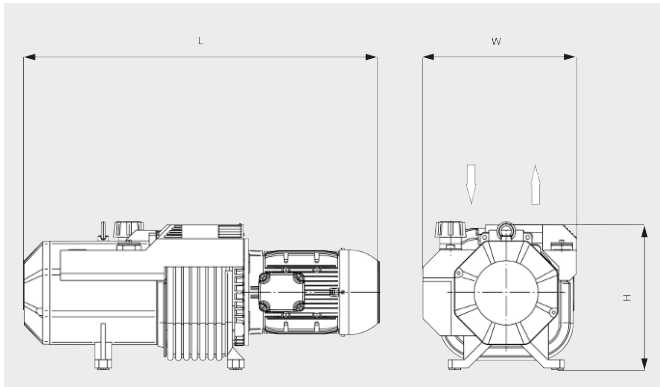

## Pumpekapasitet

Luft ved 20 °C. Toleranse: ± 10 %

— 50 Hz ..... 60 Hz

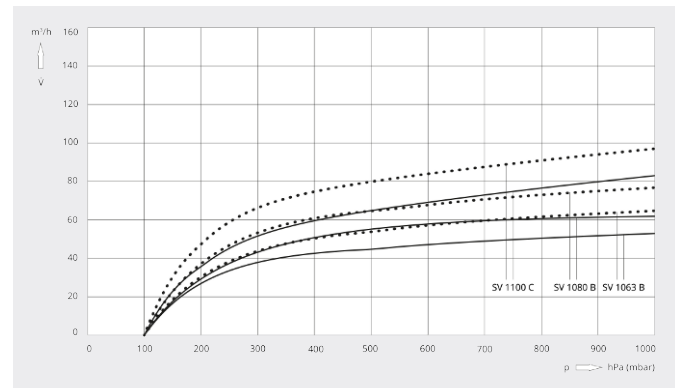

	SECO SV 1063 B	SECO SV 1080 B	SECO SV 1100 C
<b>Nominell pumpekapasitet</b>	55 / 65 m <sup>3</sup> /t (50/60 Hz)	62 / 77 m <sup>3</sup> /t (50/60 Hz)	83 / 97 m <sup>3</sup> /t (50/60 Hz)
<b>Sluttrykk</b>	100 hPa (mbar) (50/60 Hz)	100 hPa (mbar) (50/60 Hz)	100 hPa (mbar) (50/60 Hz)
<b>Nominell motoreffekt</b>	1,7 / 2,2 kW (50/60 Hz)	2,2 / 3,0 kW (50/60 Hz)	3,0 / 4,0 kW (50/60 Hz)
<b>Nominell motorhastighet</b>	1500 / 1800 min <sup>-1</sup> (50/60 Hz)	1500 / 1800 min <sup>-1</sup> (50/60 Hz)	1500 / 1800 min <sup>-1</sup> (50/60 Hz)
<b>Støynivå (ISO 2151)</b>	75 / 76 dB(A) (50/60 Hz)	76 / 77 dB(A) (50/60 Hz)	77 / 78 dB(A) (50/60 Hz)
<b>Vekt ca.</b>	82 kg	90 kg	120 kg
<b>Mål (L × B × H)</b>	763 x 428 x 342 mm	798 x 428 x 342 mm	849 x 375 x 346 mm
<b>Gassinløp / utløp</b>	G 1¼" / G 1¼"	G 1¼" / G 1¼"	G 1¼" / G 1¼"

## VIL DU VITE MER?

Ta kontakt med oss!  
post@busch.no eller +47 64 98 98 50



KONTAKTSKJEMA



RING NÅ