

ZEBRA RH 0003-0010 B

Two-stage oil-lubricated rotary vane vacuum pumps

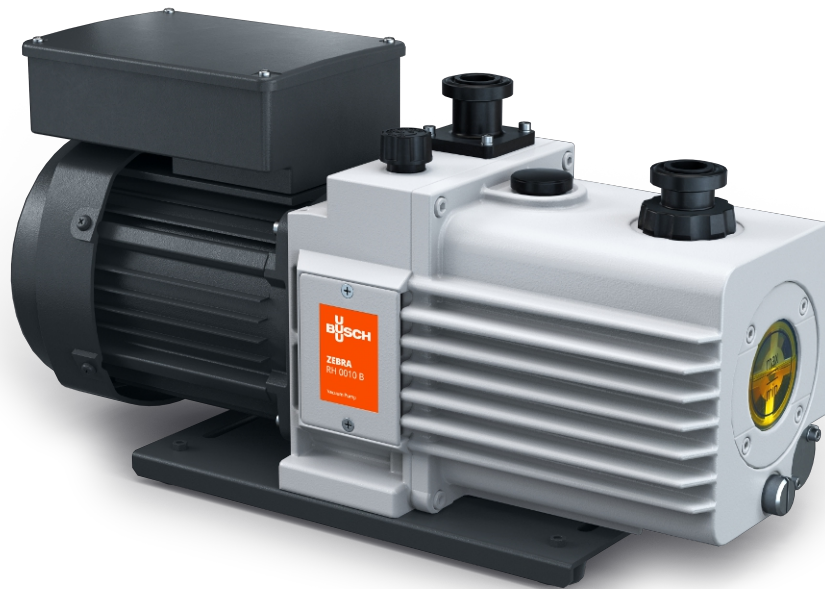

Reliable

Specially designed for a wide range of applications in the medium vacuum range, robust construction, proven rotary vane vacuum technology

High performance

Stable pumping speed even in low pressure range

Quiet

Perfectly suited for research labs and low-noise working environments, < 60 dB(A) at 50 Hz

Accessories, spare parts and options

- Inlet filter
- Oil mist separator
- Gas-ballast valve

ZEBRA RH 0003-0010 B

Two-stage oil-lubricated rotary vane vacuum pumps



Dimensional drawing

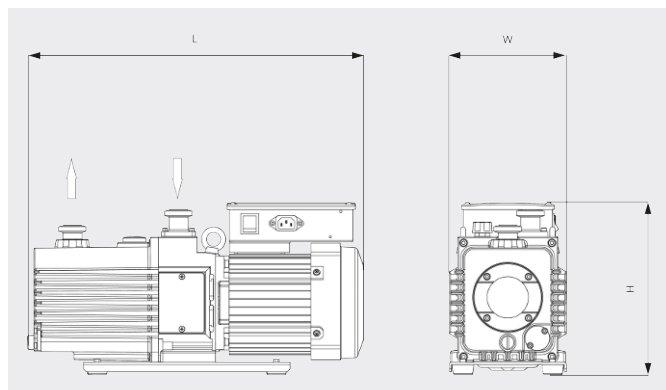

Pumping speed

Air at 20°C. Tolerance: ± 10%

— 50 Hz 60 Hz

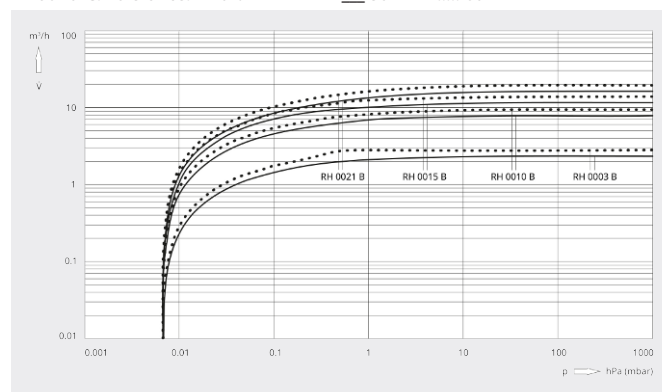

	ZEBRA RH 0003 B	ZEBRA RH 0010 B	ZEBRA RH 0010 B
Pumping speed	2.4 / 2.9 m³/h (50 / 60 Hz)	8.1 / 9.7 m³/h (50 / 60 Hz)	8.1 / 9.7 m³/h (50 / 60 Hz)
Pumping speed	40 / 48 l/min (50 / 60 Hz)	135 / 162 l/min (50 / 60 Hz)	135 / 162 l/min (50 / 60 Hz)
Ultimate partial pressure (gas-ballast valve closed)	$6.7 \cdot 10^{-4}$ hPa (mbar)	$6.7 \cdot 10^{-4}$ hPa (mbar)	$6.7 \cdot 10^{-4}$ hPa (mbar)
Ultimate total pressure (gas-ballast valve closed)	$6.7 \cdot 10^{-3}$ hPa (mbar)	$6.7 \cdot 10^{-3}$ hPa (mbar)	$6.7 \cdot 10^{-3}$ hPa (mbar)
Ultimate total pressure (gas-ballast valve open)	$6.7 \cdot 10^{-2}$ hPa (mbar)	$6.7 \cdot 10^{-2}$ hPa (mbar)	$6.7 \cdot 10^{-2}$ hPa (mbar)
Max. continuous inlet pressure	100 hPa (mbar)	100 hPa (mbar)	100 hPa (mbar)
Max. back pressure (gauge)	300 hPa (mbar)	300 hPa (mbar)	300 hPa (mbar)
Water vapor capacity (gas-ballast valve open)	5 g/h	38 g/h	38 g/h
Nominal motor rating	0.2 kW	0.4 kW	0.4 kW
Operating voltage	100 – 120 / 200 – 240 V (50 / 60 Hz)	100 – 120 / 200 – 240 V (50 / 60 Hz)	200 – 240 / 380 – 415 / 200 – 240 / 380 – 460 V (50 / 60 Hz)
Motor phase	Single-phase	Single-phase	Three-phase
Ambient temperature	7 – 40 °C	7 – 40 °C	7 – 40 °C
Oil	VSD 026	VMA 055	VMA 055
Oil capacity	0.8 l	1 l	1 l

ZEBRA RH 0003-0010 B

Two-stage oil-lubricated rotary vane vacuum pumps



VACUUM SOLUTIONS

	ZEBRA RH 0003 B	ZEBRA RH 0010 B	ZEBRA RH 0010 B
Noise level (ISO 2151)	< 52 / < 53 dB(A) (50 / 60 Hz)	< 52 / < 54 dB(A) (50 / 60 Hz)	< 49 / < 52 dB(A) (50 / 60 Hz)
Weight approx.	16 kg	29 kg	26 kg
Dimensions (L x W x H)	427 x 150 x 228 mm	488 x 170 x 250 mm	486 x 170 x 250 mm
Gas inlet / outlet	ISO-KF 25 / ISO-KF 25	ISO-KF 25 / ISO-KF 25	ISO-KF 25 / ISO-KF 25
Marking	cTUVus	cTUVus	cTUVus
Additional information	<ul style="list-style-type: none">• M/A switch• Prefilled with VSD 026 oil	<ul style="list-style-type: none">• M/A switch• Prefilled with VMA 055 oil	<ul style="list-style-type: none">• Terminal box• Prefilled with VMA 055 oil

DO YOU WANT TO KNOW MORE?

Get in touch with us directly!
busch@busch.com.my or +60 (0)3 55 25 95 00



CONTACT FORM



CALL NOW