

DOLPHIN LR 1560/2200 A

Liquid ring vacuum pumps



VACUUM SOLUTIONS



Robust

Proven technology, reliable operation, extremely high vapor and particle tolerance, specially designed for challenging environments like mining, power plants, sugar production, pulp and paper industry, steel production etc.

High performance

High-capacity, high pumping speeds

Flexible

Modular design, choice of cast iron (EN-GJL-200) housing with ductile cast iron impeller or all 304 grade, or 316L grade corrosion-free stainless steel material, operating fluids other than water possible, operation as compressor possible

Accessories

- Motorized pumpsets, with gearbox or V-belt drive system, mounted on sturdy steel base frames
- Partial or total recirculation systems
- Cavitation protection
- Gas ejector
- Non-return valves
- Vacuum relief valves

DOLPHIN LR 1560/2200 A

Liquid ring vacuum pumps



VACUUM SOLUTIONS

Dimensional drawing

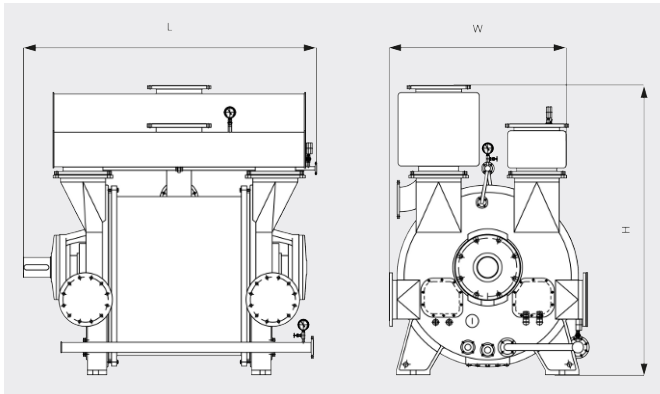

Pumping speed

Air at 20°C. Tolerance: ± 10%

— 50 Hz 60 Hz

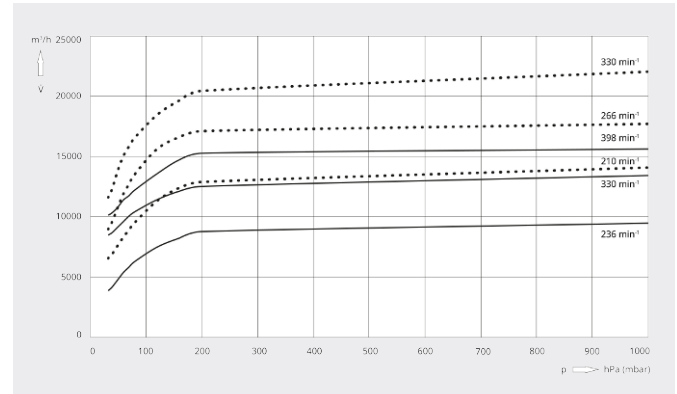

	DOLPHIN LR 1560 A	DOLPHIN LR 2200 A
Nominal pumping speed	9500 – 15600 m ³ /h	14100 – 22000 m ³ /h
Ultimate pressure	33 hPa (mbar)	33hPa (mbar)
Nominal motor rating	220 – 450 kW	355 – 600 kW
Nominal motor speed	236 – 398 min ⁻¹	210 – 330 min ⁻¹
Noise level (ISO 2151)	< 85 dB(A)	< 85 dB(A)
Weight approx.	8340 kg	12000 kg
Dimensions (L x W x H)	2512 x 1785 x 2560 mm	2891 x 2065 x 2965 mm
Gas inlet / outlet	DN 400 PN 10 / DN 400 PN 10	DN 500 PN 10 / DN 500 PN 10

DO YOU WANT TO KNOW MORE?

Get in touch with us directly!
busch@busch.com.my or +60 (0)3 55 25 95 00



CONTACT FORM



CALL NOW