

SIMPLEX VD 0025-0100 G

Vacuum System

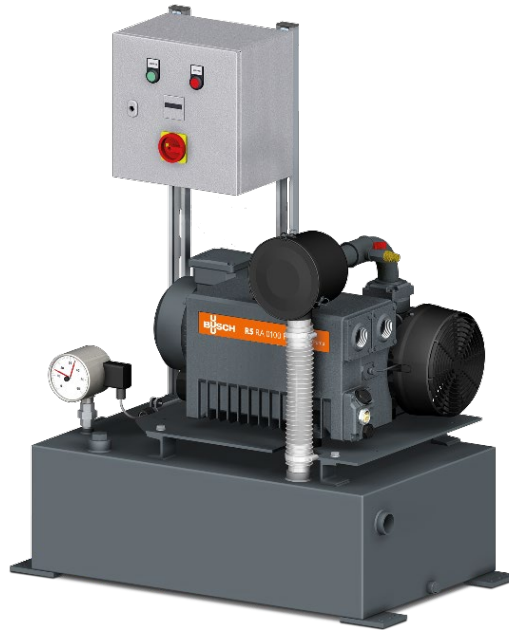

Efficient

Low energy consumption, can replace several individual vacuum pumps, nearly maintenance-free

Flexible

Application-oriented, easy installation, no unnecessary run-times due to autonomous pressure control, optimum safety through a vacuum vessel

Compact

Vacuum vessel mounted directly beneath the vacuum pump

Accessories / Spare Parts

- Mobile version on casters
- Vacuum pump oils for all applications

SIMPLEX VD 0025-0100 G

Vacuum System



Dimensional drawing

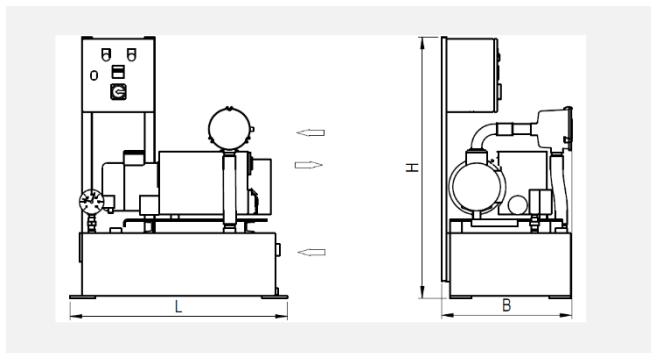

Pumping speed

Air at 20°C. Tolerance: ± 10% ; 50 Hz

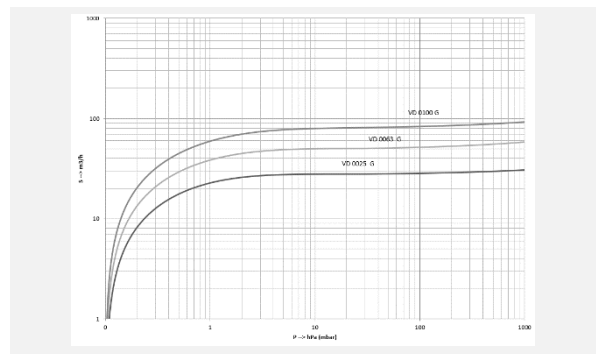

Technical data

	VD 0025 G	VD 0063 G	VD 0100 G
Nominal pumping speed	25 m ³ /h	63 m ³ /h	100 m ³ /h
Ultimate pressure	1,5 hPa (mbar)	1,5 hPa (mbar)	1,5 hPa (mbar)
Nominal motor rating	1 kW	2 kW	2,7 kW
Nominal system rating	1,5 kW	2,5 kW	3 kW
Noise level (ISO 2151)	60 dB(A)	64 dB(A)	65 dB(A)
Oil capacity	1 l	2 l	2 l
Volume vacuum vessel	100 l	100 l	100 l
Weight approx.	110 kg	127 kg	155 kg
Dimensions (L x W x H)	900 x 549 x 1079 mm	900 x 556 x 1079 mm	900 x 556 x 1079 mm
Gas inlet / outlet	G 1 ¼" / G 1 ¼"	G 1 ¼" / G 1 ¼"	G 1 ¼" / G 1 ¼"

Technical data only for 50 Hz, as operating voltage of control panel 380-400 V / 50 Hz

DO YOU WANT TO KNOW MORE?

Get in touch with us directly!
sales@busch.de or +49 7622 681-0