

PUMA WP 0700/1000 D/D2/ D4

Vacuum boosters



VACUUM SOLUTIONS



Reliable

Solid lobe design, robust construction made of GGG40 material

High performance

Excellent volumetric efficiency, increases the performance of a vacuum system by up to a factor of ten, specially designed for rough and medium vacuum applications

Flexible

Can be flanged directly on the system at any position, boosts the performance of all types of backing pumps

PUMA WP 0700/1000 D/D2/D4

Vacuum boosters



Dimensional drawing

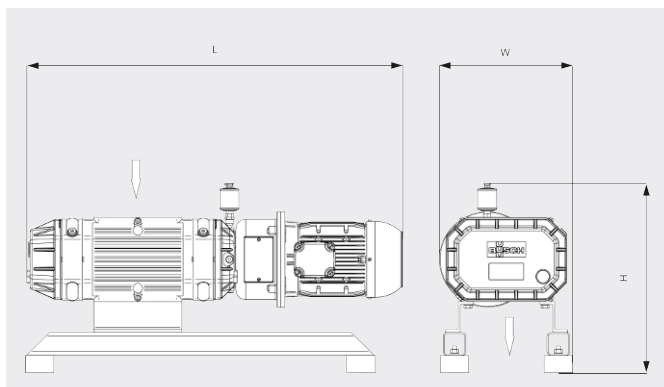

Pumping speed
Air at 20°C. Tolerance: ± 10%

— 50 Hz 60 Hz

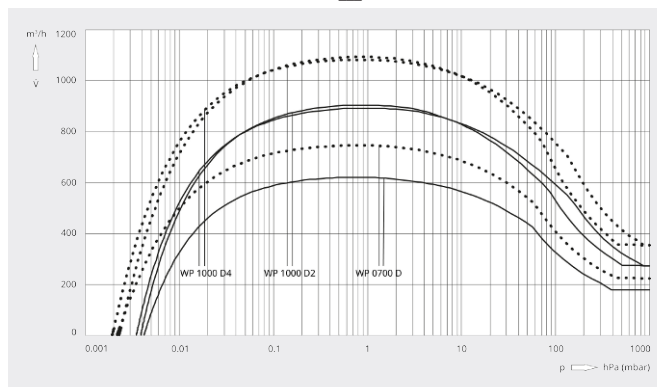

	PUMA WP 0700 D	PUMA WP 1000 D2	PUMA WP 1000 D4
Nominal pumping speed	700 / 840 m³/h (50 / 60 Hz)	1000 / 1200 m³/h (50 / 60 Hz)	1000 / 1200 m³/h (50 / 60 Hz)
Pumping speed	620 / 750 m³/h (50 / 60 Hz)	900 / 1090 m³/h (50 / 60 Hz)	900 / 1090 m³/h (50 / 60 Hz)
Max. differential pressure	50 hPa (mbar) (50 / 60 Hz)	50 hPa (mbar) (50 / 60 Hz)	80 hPa (mbar) (50 / 60 Hz)
Nominal motor rating	3.5 / 4.8 kW (50 / 60 Hz)	3.5 / 4.8 kW (50 / 60 Hz)	5.5 / 6.6 kW (50 / 60 Hz)
Nominal motor speed	3000 / 3600 min ⁻¹ (50 / 60 Hz)	3000 / 3600 min ⁻¹ (50 / 60 Hz)	1500 / 1800 min ⁻¹ (50 / 60 Hz)
Weight approx.	190 kg	200 kg	350 kg
Dimensions (L x W x H)	905 x 345 x 494 mm	992 x 345 x 494 mm	1244 x 420 x 578 mm
Gas inlet / outlet	DN 100 ISO / DN 100 ISO	DN 160 ISO / DN 160 ISO	DN 160 ISO / DN 160 ISO

DO YOU WANT TO KNOW MORE?

Get in touch with us directly!



CONTACT FORM