

# COBRA NC 0100-0300 B

Dry screw vacuum pumps



VACUUM SOLUTIONS



## High performance

Advanced screw design, patented self-balancing screws, perfectly suited for chemical processes, distillation and vacuum drying

## Efficient

Low cost of ownership, minimal maintenance, long service intervals, high uptime, efficient water cooling

## Flexible

Air cooling, various sealing and coating configurations as well as ATEX-certified versions available

### Accessories

- Purge gas system
- Sealing gas supply
- Dilution gas supply
- Connection adapter to connect ISO or ASME flanges
- Non-return valve
- Exhaust gas silencer
- Air cooling
- Various sealing and coating configurations
- ATEX-certified versions available

# COBRA NC 0100-0300 B

Dry screw vacuum pumps



VACUUM SOLUTIONS

Dimensional drawing

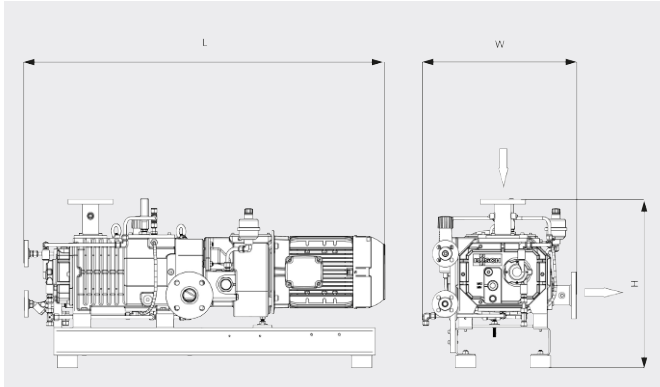

Pumping speed

Air at 20°C. Tolerance: ± 10%

— 50 Hz ..... 60 Hz

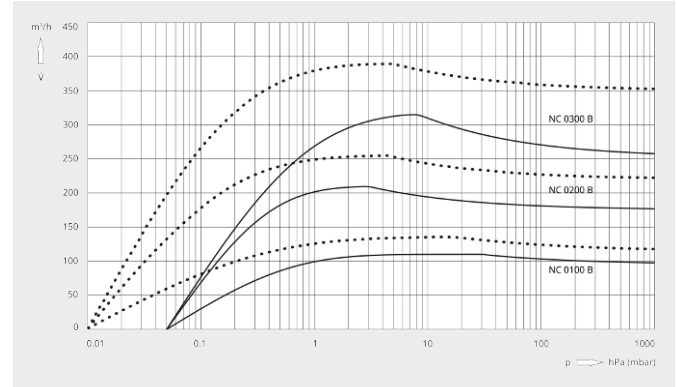

	COBRA NC 0100 B	COBRA NC 0200 B	COBRA NC 0300 B
<b>Pumping speed</b>	110 / 130 m³/h (50 / 60 Hz)	220 / 265 m³/h (50 / 60 Hz)	320 / 385 m³/h (50 / 60 Hz)
<b>Ultimate pressure</b>	≤ 0.05 / ≤ 0.01 hPa (mbar) (50 / 60 Hz)	≤ 0.05 / ≤ 0.01 hPa (mbar) (50 / 60 Hz)	≤ 0.05 / ≤ 0.01 hPa (mbar) (50 / 60 Hz)
<b>Nominal motor rating</b>	3.5 / 4.8 kW (50 / 60 Hz)	6.0 / 7.6 kW (50 / 60 Hz)	7.5 / 9.5 kW (50 / 60 Hz)
<b>Nominal motor speed</b>	3000 / 3600 min <sup>-1</sup> (50 / 60 Hz)	3000 / 3600 min <sup>-1</sup> (50 / 60 Hz)	3000 / 3600 min <sup>-1</sup> (50 / 60 Hz)
<b>Noise level (ISO 2151)</b>	≤ 70 / ≤ 74 dB(A) (50 / 60 Hz)	≤ 71 / ≤ 76 dB(A) (50 / 60 Hz)	≤ 72 / ≤ 77 dB(A) (50 / 60 Hz)
<b>Weight approx.</b>	300 kg	350 kg	400 kg
<b>Dimensions (L x W x H)</b>	1127 x 520 x 595 mm	1264 x 520x 607 mm	1334 x 520 x 607 mm
<b>Gas inlet / outlet</b>	DN 40 PN 16 / DN 40 PN 16	DN 50 PN 16 / DN 50 PN 16	DN 50 PN 16 / DN 50 PN 16

## DO YOU WANT TO KNOW MORE?

Get in touch with us directly!  
[sales@buschindia.com](mailto:sales@buschindia.com) or +91 (0)124 475 1300



CONTACT FORM



CALL NOW