

# MINK MV 1202 B

Dry claw vacuum pump



Discover all advantages of the product series MINK MV

## Quiet

Low noise level due to a state-of-the-art acoustic design, can be installed at workstations

## Efficient

Latest claw vacuum technology, low energy consumption, minimized operating costs, nearly maintenance-free, effective air cooling

## Compact

Small footprint

### Accessories

- Aqua version
- IoT kit
- ATEX Category 3

# MINK MV 1202 B

Dry claw vacuum pump



VACUUM SOLUTIONS

## Dimensional drawing

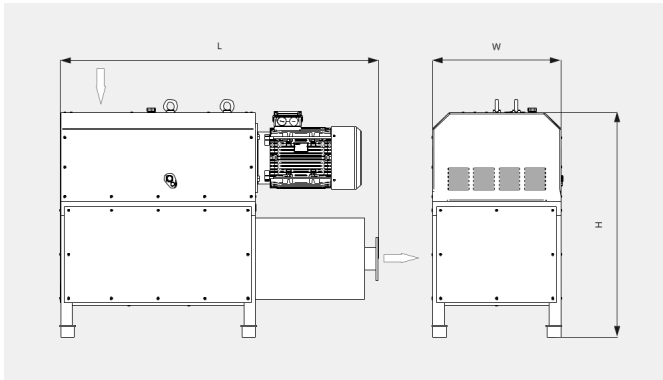

## Pumping speed

Air at 20 °C. Tolerance:  $\pm 10\%$

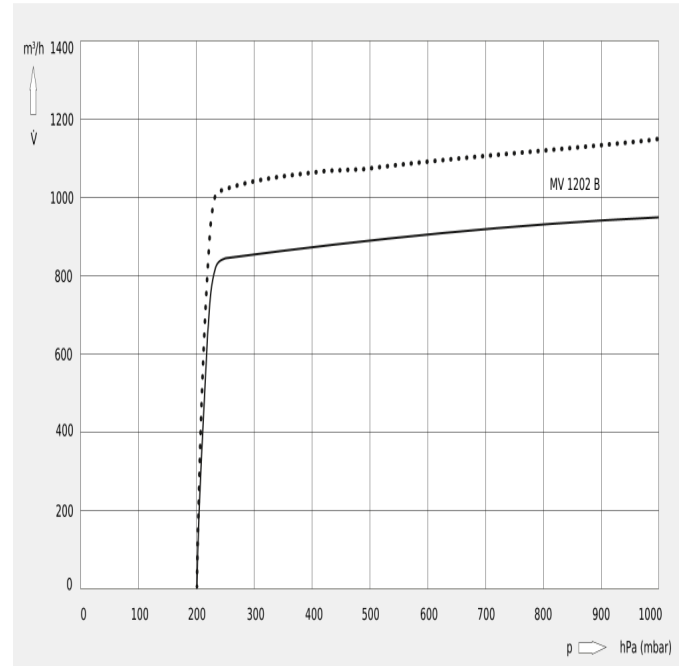

The following technical values refer to ISO 50 Hz

MINK MV 1202 B	
Nominal pumping speed	950 m <sup>3</sup> /h
Ultimate pressure	200 hPa (mbar)
Nominal motor rating	18.5 kW
Nominal motor speed	3000 min <sup>-1</sup>
Noise level (ISO 2151)	79 dB(A)
Oil capacity	3.5 l
Weight approx.	900 kg
Dimensions (L x W x H)	1620 x 670 x 1210 mm
Gas inlet	DN 100, PN 10/16
Gas outlet	DN 100, PN 10/16

# MINK MV 1202 B

Dry claw vacuum pump



The following technical values refer to ISO 60 Hz

MINK MV 1202 B	
Nominal pumping speed	1150 m <sup>3</sup> /h
Ultimate pressure	200 hPa (mbar)
Nominal motor rating	22.0 kW
Nominal motor speed	3600 min <sup>-1</sup>
Noise level (ISO 2151)	82 dB(A)
Oil capacity	3.5 l
Weight approx.	900 kg
Dimensions (L x W x H)	1620 x 670 x 1210 mm
Gas inlet	DN 100, PN 10/16
Gas outlet	DN 100, PN 10/16

## DO YOU WANT TO KNOW MORE

Please contact us!  
[service\\_sales@busch.co.il](mailto:service_sales@busch.co.il) or +972 (0)8 6810485



CONTACT FORM



CALL US NOW