

# ZEBRA RH 0003-0010 B

Two-stage oil-lubricated rotary vane vacuum pumps

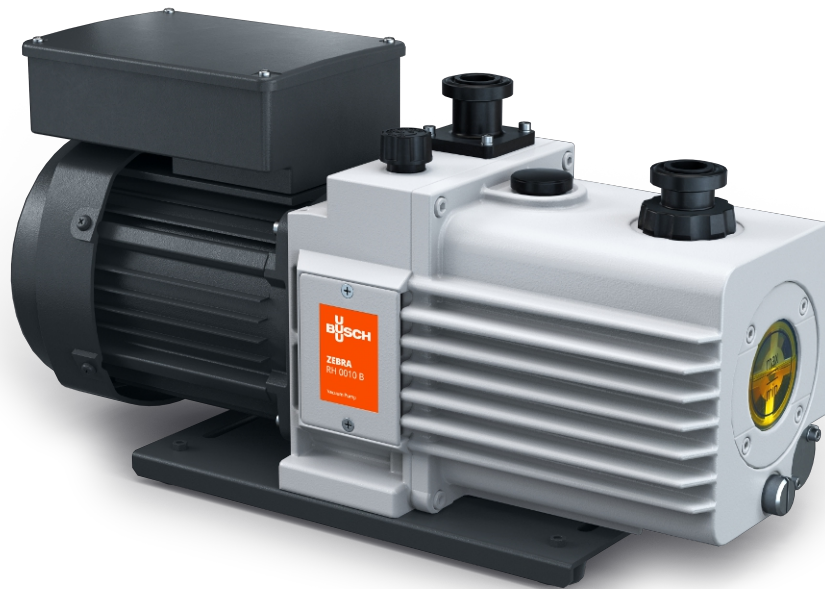

## Reliable

Specially designed for a wide range of applications in the medium vacuum range, robust construction, proven rotary vane vacuum technology

## High performance

Stable pumping speed even in low pressure range

## Quiet

Perfectly suited for research labs and low-noise working environments, < 60 dB(A) at 50 Hz

Accessories, spare parts and options

- Inlet filter
- Oil mist separator
- Gas-ballast valve

# ZEBRA RH 0003-0010 B

Two-stage oil-lubricated rotary vane vacuum pumps



VACUUM SOLUTIONS

Dimensional drawing

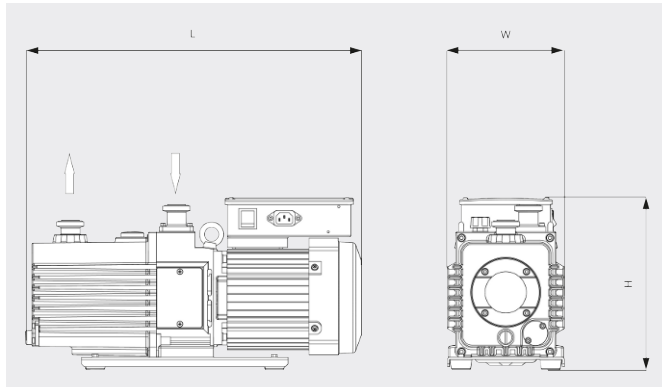

Pumping speed

Air at 20°C. Tolerance: ± 10%

— 50 Hz ..... 60 Hz

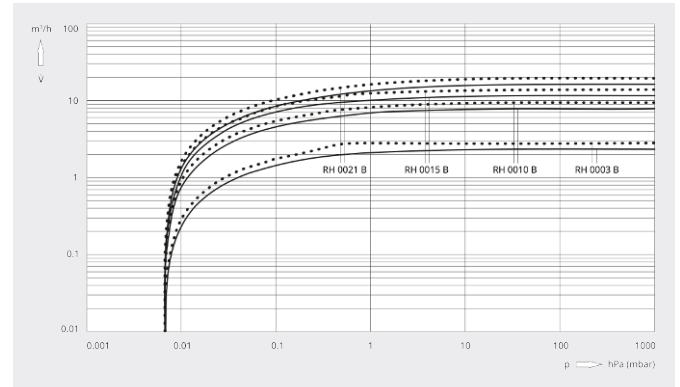

	ZEBRA RH 0003 B	ZEBRA RH 0010 B	ZEBRA RH 0010 B
<b>Pumping speed</b>	2.4 / 2.9 m³/h (50 / 60 Hz)	8.1 / 9.7 m³/h (50 / 60 Hz)	8.1 / 9.7 m³/h (50 / 60 Hz)
<b>Pumping speed</b>	40 / 48 l/min (50 / 60 Hz)	135 / 162 l/min (50 / 60 Hz)	135 / 162 l/min (50 / 60 Hz)
<b>Ultimate partial pressure (gas-ballast valve closed)</b>	$6.7 \cdot 10^{-4}$ hPa (mbar)	$6.7 \cdot 10^{-4}$ hPa (mbar)	$6.7 \cdot 10^{-4}$ hPa (mbar)
<b>Ultimate total pressure (gas-ballast valve closed)</b>	$6.7 \cdot 10^{-3}$ hPa (mbar)	$6.7 \cdot 10^{-3}$ hPa (mbar)	$6.7 \cdot 10^{-3}$ hPa (mbar)
<b>Ultimate total pressure (gas-ballast valve open)</b>	$6.7 \cdot 10^{-2}$ hPa (mbar)	$6.7 \cdot 10^{-2}$ hPa (mbar)	$6.7 \cdot 10^{-2}$ hPa (mbar)
<b>Max. continuous inlet pressure</b>	100 hPa (mbar)	100 hPa (mbar)	100 hPa (mbar)
<b>Max. back pressure (gauge)</b>	300 hPa (mbar)	300 hPa (mbar)	300 hPa (mbar)
<b>Water vapor capacity (gas-ballast valve open)</b>	5 g/h	38 g/h	38 g/h
<b>Nominal motor rating</b>	0.2 kW	0.4 kW	0.4 kW
<b>Operating voltage</b>	100 – 120 / 200 – 240 V (50 / 60 Hz)	100 – 120 / 200 – 240 V (50 / 60 Hz)	200 – 240 / 380 – 415 / 200 – 240 / 380 – 460 V (50 / 60 Hz)
<b>Motor phase</b>	Single-phase	Single-phase	Three-phase
<b>Ambient temperature</b>	7 – 40 °C	7 – 40 °C	7 – 40 °C
<b>Oil</b>	VSD 026	VMA 055	VMA 055
<b>Oil capacity</b>	0.8 l	1 l	1 l

# ZEBRA RH 0003-0010 B

Two-stage oil-lubricated rotary vane vacuum pumps



VACUUM SOLUTIONS

	ZEBRA RH 0003 B	ZEBRA RH 0010 B	ZEBRA RH 0010 B
Noise level (ISO 2151)	< 52 / < 53 dB(A) (50 / 60 Hz)	< 52 / < 54 dB(A) (50 / 60 Hz)	< 49 / < 52 dB(A) (50 / 60 Hz)
Weight approx.	16 kg	29 kg	26 kg
Dimensions (L x W x H)	427 x 150 x 228 mm	488 x 170 x 250 mm	486 x 170 x 250 mm
Gas inlet / outlet	ISO-KF 25 / ISO-KF 25	ISO-KF 25 / ISO-KF 25	ISO-KF 25 / ISO-KF 25
Marking	cTUVus	cTUVus	cTUVus
Additional information	<ul style="list-style-type: none"><li>• M/A switch</li><li>• Prefilled with VSD 026 oil</li></ul>	<ul style="list-style-type: none"><li>• M/A switch</li><li>• Prefilled with VMA 055 oil</li></ul>	<ul style="list-style-type: none"><li>• Terminal box</li><li>• Prefilled with VMA 055 oil</li></ul>

## DO YOU WANT TO KNOW MORE?

Get in touch with us directly!  
[service\\_sales@busch.co.il](mailto:service_sales@busch.co.il) or +972 (0)8 681 04 85



CONTACT FORM



CALL NOW