

# R5 RU 0050/0070 B

Oil-lubricated rotary vane vacuum pumps



Discover all advantages of the product series R5 RU

## Reliable

Robust construction, proven rotary vane technology, special chemical-resistant oil, electromagnetic compatibility in accordance with directive 2014/30/EU, approved according to UL 61010-1 and EN 61010-1

## High performance

Specially designed for use in analytical and scientific applications, variable speed drive

## Quiet

State-of-the-art acoustic design, low noise and vibration levels, ideal for installation at workstations

# R5 RU 0050/0070 B

## Oil-lubricated rotary vane vacuum pumps

### Dimensional drawing

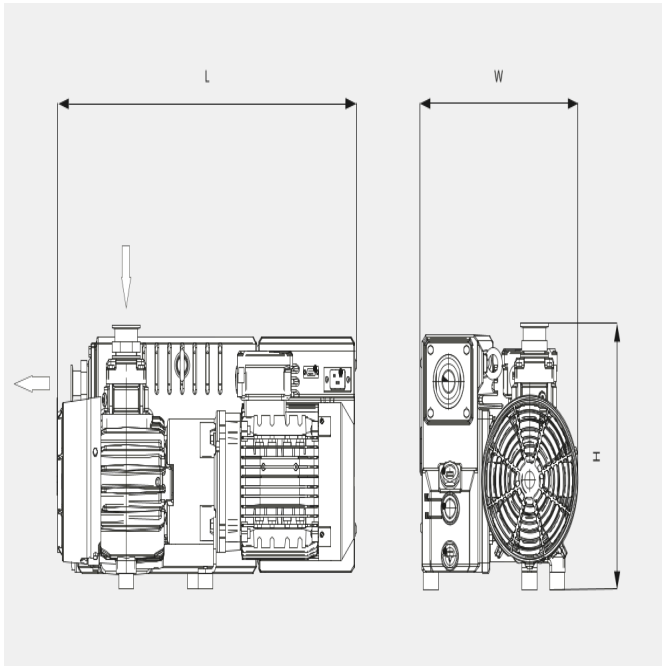

### Pumping speed

Air at 20 °C. Tolerance: ± 10%

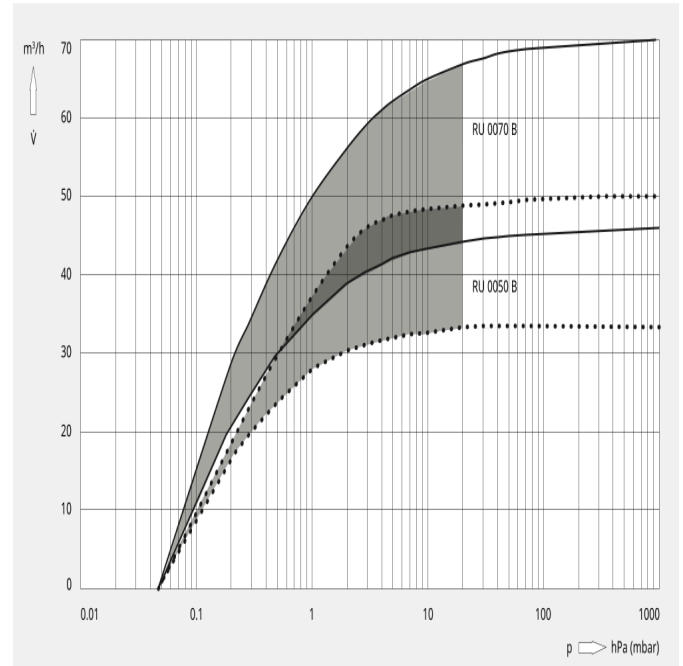

The following technical values refer to ISO 50 Hz

	R5 RU 0050 B	R5 RU 0070 B
<b>Pumping speed (m³/h)</b>	50 m³/h	70 m³/h
<b>Pumping speed (l/min)</b>	833 l/min	1167 l/min
<b>Pumping speed at 3 mbar (m³/h)</b>	46 m³/h	59 m³/h
<b>Pumping speed at 3 mbar (l/min)</b>	767 l/min	983 l/min
<b>Ultimate pressure</b>	< 0.05 hPa (mbar)	< 0.05 hPa (mbar)
<b>Nominal motor rating</b>	1.2 kW	1.2 kW
<b>Nominal voltage</b>	200–240 ± 10% V	200–240 ± 10% V
<b>Ambient temperature</b>	12–50 °C	12–50 °C
<b>Noise level (ISO 2151) at 3 mbar and 1800 min#¹</b>	57 dB(A)	57 dB(A)
<b>Oil capacity</b>	1.7 l	1.7 l
<b>Weight approx.</b>	56 kg	56 kg

# R5 RU 0050/0070 B

Oil-lubricated rotary vane vacuum pumps



VACUUM SOLUTIONS

	R5 RU 0050 B	R5 RU 0070 B
Dimensions (L x W x H)	591 x 311 x 287 mm	601 x 311 x 287 mm
Gas outlet	DN 25 KF	DN 25 KF
Gas inlet	DN 40 KF	DN 40 KF
Safety	IEC / UL / EN 61010-1 / NRTL mark	IEC / UL / EN 61010-1 / NRTL mark
Immunity	EN 61326-1 Table 2, EN 61000-6-2	EN 61326-1 Table 2, EN 61000-6-2
Protection class	IP20	IP20
Emissions	EN 61000-3-2 class A, EN 61000-6-4 CISPR 11 class A, CFR 47 FCC part 15 class A, EN 55011, EN 61326-1	EN 61000-3-2 class A, EN 61000-6-4 CISPR 11 class A, CFR 47 FCC part 15 class A, EN 55011, EN 61326-1

The following technical values refer to ISO 60 Hz

	R5 RU 0050 B	R5 RU 0070 B
Pumping speed (m <sup>3</sup> /h)	50 m <sup>3</sup> /h	70 m <sup>3</sup> /h
Pumping speed (l/min)	833 l/min	1167 l/min
Pumping speed at 3 mbar (m <sup>3</sup> /h)	46 m <sup>3</sup> /h	59 m <sup>3</sup> /h
Pumping speed at 3 mbar (l/min)	767 l/min	983 l/min
Ultimate pressure	< 0.05 hPa (mbar)	< 0.05 hPa (mbar)
Nominal motor rating	1.2 kW	1.2 kW
Nominal voltage	200–240 ± 10% V	200–240 ± 10% V
Ambient temperature	12–50 °C	12–50 °C
Noise level (ISO 2151) at 3 mbar and 1800 min <sup>#1</sup>	57 dB(A)	57 dB(A)
Oil capacity	1.7 l	1.7 l
Weight approx.	56 kg	56 kg
Dimensions (L x W x H)	591 x 311 x 287 mm	601 x 311 x 287 mm
Gas outlet	DN 25 KF	DN 25 KF
Gas inlet	DN 40 KF	DN 40 KF
Safety	IEC / UL / EN 61010-1 / NRTL mark	IEC / UL / EN 61010-1 / NRTL mark
Immunity	EN 61326-1 Table 2, EN 61000-6-2	EN 61326-1 Table 2, EN 61000-6-2

# R5 RU 0050/0070 B

Oil-lubricated rotary vane vacuum pumps



	R5 RU 0050 B	R5 RU 0070 B
<b>Protection class</b>	IP20	IP20
<b>Emissions</b>	EN 61000-3-2 class A, EN 61000-6-4 CISPR 11 class A, CFR 47 FCC part 15 class A, EN 55011, EN 61326-1	EN 61000-3-2 class A, EN 61000-6-4 CISPR 11 class A, CFR 47 FCC part 15 class A, EN 55011, EN 61326-1

## DO YOU WANT TO KNOW MORE

Please contact us!  
[sales@busch.ie](mailto:sales@busch.ie) or +353 (0)1 8321330



CONTACT FORM



CALL US NOW