

R5 KB 0020-0040 D/F

Oil-lubricated rotary vane vacuum pumps



Compact

Direct-drive construction, reduced height and weight, ideal for installation in vacuum packaging machines

Flexible

Various design options available, easy adaption to individual customer requirements and processes

Reliable

Robust construction, highly durable vanes, proven rotary vane technology, long service life

Accessories, spare parts and options

- Gas-ballast valve
- Filter pressure gauge
- Vacuum pump oils for all applications
- Various inlet filters
- Oil level switch
- Vacuum regulating unit

R5 KB 0020-0040 D/F

Oil-lubricated rotary vane vacuum pumps



VACUUM SOLUTIONS

Dimensional drawing

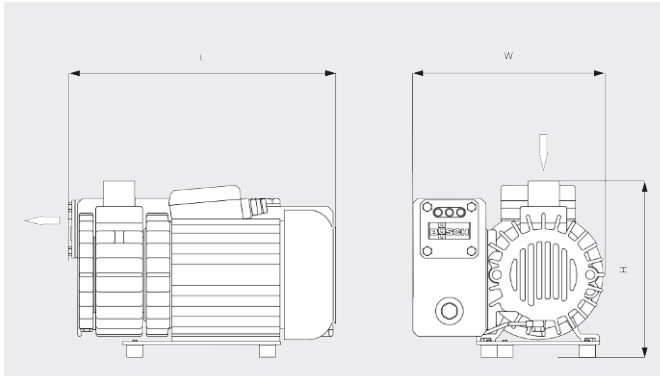

Pumping speed

Air at 20°C. Tolerance: ± 10%

— 50 Hz 60 Hz

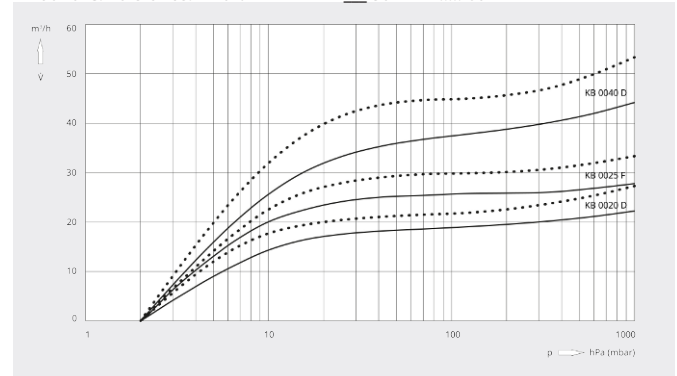

	R5 KB 0020 D	R5 KB 0025 F	R5 KB 0040 D
Nominal pumping speed	20 / 24 m³/h (50 / 60 Hz)	25 / 30 m³/h (50 / 60 Hz)	40 / 48 m³/h (50 / 60 Hz)
Ultimate pressure	2.0 hPa (mbar) (50 / 60 Hz)	2.0 hPa (mbar) (50 / 60 Hz)	2.0 hPa (mbar) (50 / 60 Hz)
Nominal motor rating	0.75 kW (50 / 60 Hz)	0.9 / 1.1 kW (50 / 60 Hz)	1.5 kW (50 / 60 Hz)
Nominal motor speed	3000 / 3600 min ⁻¹ (50 / 60 Hz)	3000 / 3600 min ⁻¹ (50 / 60 Hz)	3000 / 3600 min ⁻¹ (50 / 60 Hz)
Noise level (ISO 2151)	67 / 70 dB(A) (50 / 60 Hz)	68 / 69 dB(A) (50 / 60 Hz)	69 / 71 dB(A) (50 / 60 Hz)
Oil capacity	0.45 l	0.45 l	0.8 l
Weight approx.	19 kg	20 kg	29 kg
Dimensions (L x W x H)	323 x 231 x 211 mm	347 x 250 x 229 mm	432 x 256 x 238 mm
Gas inlet / outlet	G ¾" / -	G ¾" / -	G 1¼" / G 1¼"

DO YOU WANT TO KNOW MORE?

Get in touch with us directly!
busch@buschvacuum.hu or +36 24 887 308



CONTACT FORM



CALL NOW