

COBRA NC 2500 B

Dry screw vacuum pump



VACUUM SOLUTIONS



High performance

Advanced screw design, patented self-balancing screws, perfectly suited for steel degassing, space simulation or vacuum drying

Efficient

Low cost of ownership, minimal maintenance, long service intervals, high uptime, efficient water cooling

Flexible

Various sealing configurations and ATEX-certified versions available

Accessories

- Seal gas system
- Dilution gas system
- Adapter for ASME flanges
- Exhaust silencer
- Various sealing configurations
- ATEX-certified versions available

COBRA NC 2500 B

Dry screw vacuum pump



VACUUM SOLUTIONS

Dimensional drawing

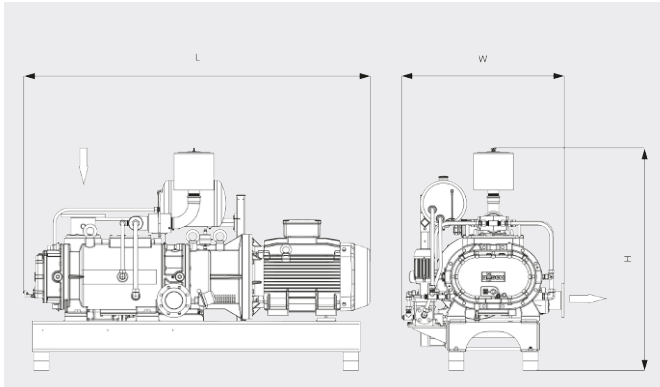

Pumping speed

Air at 20°C. Tolerance: ± 10%

— 50 Hz 60 Hz

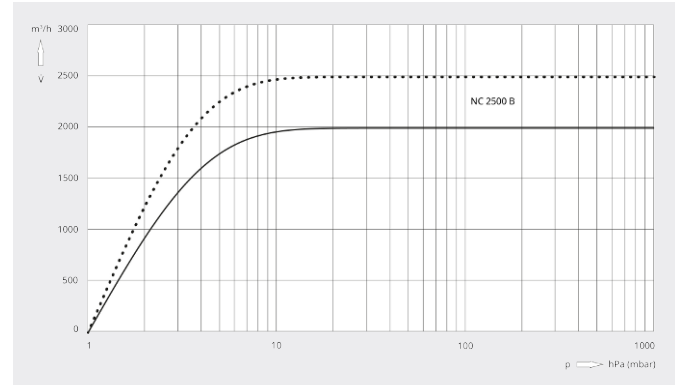

COBRA NC 2500 B	
Nominal pumping speed	2000 / 2500 m³/h (50 / 60 Hz)
Ultimate pressure	≤ 1.0 hPa (mbar) (50 / 60 Hz)
Nominal motor rating	55.0 / 63.0 kW (50 / 60 Hz)
Nominal motor speed	3000 / 3600 min ⁻¹ (50 / 60 Hz)
Noise level (ISO 2151)	82 / 84 dB(A) (50 / 60 Hz)
Weight approx.	2000 kg
Dimensions (L x W x H)	2243 x 1053 x 1437 mm
Gas inlet / outlet	DN 150 PN 16 / DN 100 PN 16

DO YOU WANT TO KNOW MORE?

Get in touch with us directly!
busch@buschvacuum.hu or +36 24 887 308



CONTACT FORM



CALL NOW