

APOVAC AP 0430–0750 A

Vacuum systems for chemical and pharmaceutical industries



Proven performance

Standard vacuum system with proven DOLPHIN liquid ring vacuum pumps, specially designed for major processes in chemical and pharmaceutical industries, such as distillation, crystallization, filtration, vacuum drying

Robust

Handling of toxic, corrosive or explosive gases, extremely high vapor and particle tolerance, for harsh process conditions, double condensation to ensure minimum carryover and maximum solvent recovery

Cost-effective

Low operating costs, high uptime, minimal maintenance, long service life

APOVAC AP 0430–0750 A

Vacuum systems for chemical and pharmaceutical industries



VACUUM SOLUTIONS

Dimensional drawing

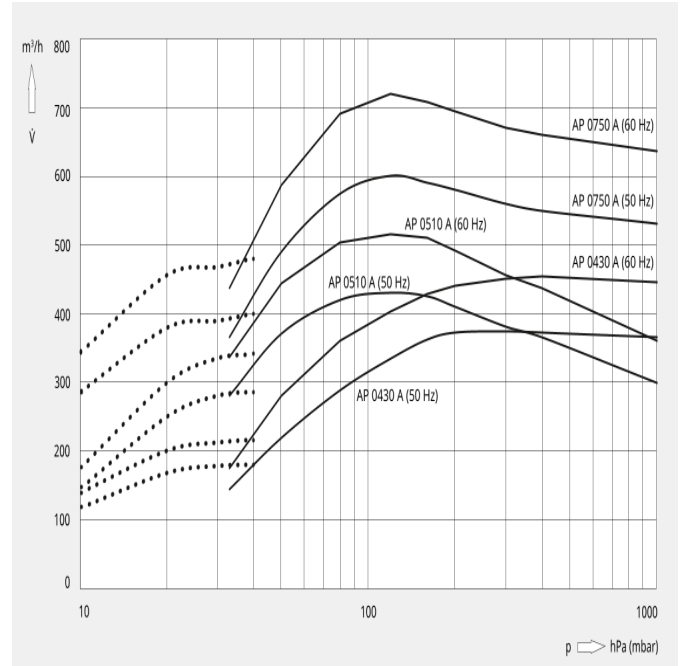
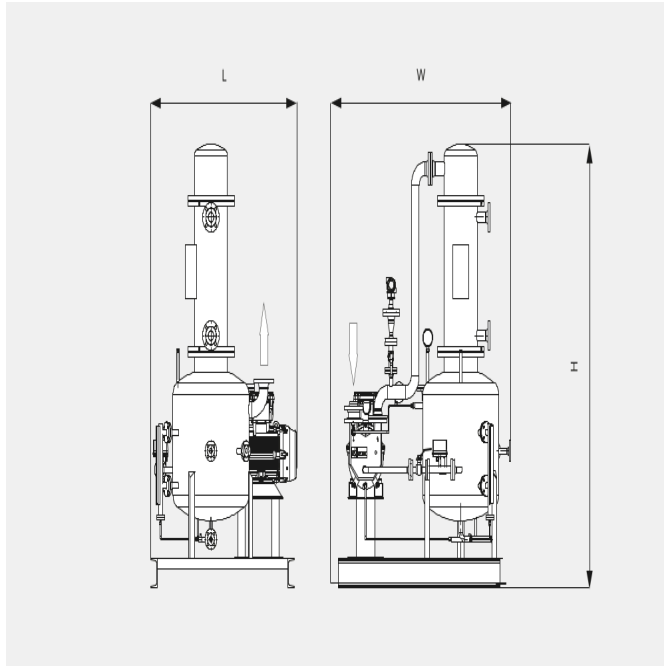

The following technical values refer to ISO 50 Hz

	AP 0430 A	AP 0510 A	AP 0750 A
Nominal pumping speed	372 m ³ /h	430 m ³ /h	617 m ³ /h
Ultimate pressure	33 hPa (mbar)	33 hPa (mbar)	33 hPa (mbar)
Nominal motor rating	11.0 kW	15.0 kW	18.5 kW
Nominal motor speed	1450 min ⁻¹	1450 min ⁻¹	1450 min ⁻¹
Weight approx.	840 kg	900 kg	950 kg
Dimensions (L x W x H)	1600 x 1400 x 2500 mm	1600 x 1400 x 2500 mm	1600 x 1400 x 2500 mm
Gas inlet	DN 65	DN 50	DN 65
Gas outlet	DN 80	DN 80	DN 80

The following technical values refer to ISO 60 Hz

	AP 0430 A	AP 0510 A	AP 0750 A
Nominal pumping speed	455 m ³ /h	510 m ³ /h	710 m ³ /h

APOVAC AP 0430–0750 A

Vacuum systems for chemical and pharmaceutical industries



VACUUM SOLUTIONS

	AP 0430 A	AP 0510 A	AP 0750 A
Ultimate pressure	10 (with optional ejector) hPa (mbar)	10 (with optional ejector) hPa (mbar)	10 (with optional ejector) hPa (mbar)
Nominal motor rating	15.0 kW	18.5 kW	30.0 kW
Nominal motor speed	1750 min ⁻¹	1750 min ⁻¹	1750 min ⁻¹
Weight approx.	840 kg	900 kg	950 kg
Dimensions (L x W x H)	1600 x 1400 x 2500 mm	1600 x 1400 x 2500 mm	1600 x 1400 x 2500 mm
Gas inlet	DN 65	DN 50	DN 65
Gas outlet	DN 80	DN 80	DN 80

DO YOU WANT TO KNOW MORE

Please contact us!
sales@busch.de or +49 (0)7622 681-3240



CONTACT FORM



CALL US NOW