

Instruction Manual

MINK Hydrogen

Hydrogen Recirculation Blower
MH 0018 A

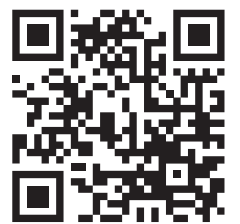
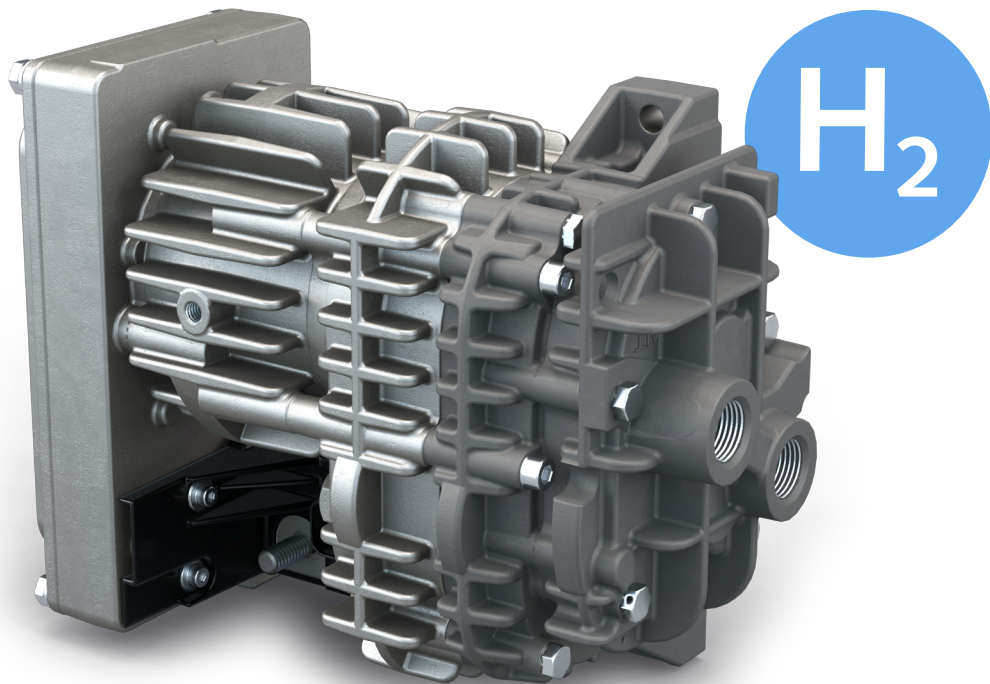

Table of Contents

| | | |
|-----------|--|-----------|
| 1 | Safety | 3 |
| 2 | Product Description | 4 |
| 2.1 | Operating Principle | 5 |
| 2.2 | Application | 5 |
| 3 | Transport | 5 |
| 4 | Storage | 6 |
| 5 | Installation | 6 |
| 5.1 | Installation Conditions..... | 6 |
| 5.2 | Connecting Lines / Pipes | 7 |
| 5.2.1 | Suction Connection | 8 |
| 5.2.2 | Discharge Connection | 8 |
| 5.3 | Electrical Connection | 9 |
| 5.3.1 | Version with Analogue Speed Control | 10 |
| 5.3.2 | Version with CAN-Communication..... | 10 |
| 5.3.3 | Motor Rotation Direction | 11 |
| 6 | Commissioning | 11 |
| 6.1 | Standard Version..... | 12 |
| 6.2 | Version with Analogue Speed Control..... | 12 |
| 6.3 | Version with CAN-Communication | 12 |
| 7 | Maintenance | 15 |
| 7.1 | Maintenance Schedule | 15 |
| 7.2 | Oil Draining | 16 |
| 7.2.1 | Overall Information | 16 |
| 7.2.2 | Draining Procedure..... | 17 |
| 7.2.3 | Service Kit and Oil Type | 22 |
| 7.2.4 | Oil Troubleshooting..... | 22 |
| 7.3 | Machine Stage Replacement | 23 |
| 7.3.1 | Stage Disassembly | 23 |
| 7.3.2 | Stage Replacement Package | 26 |
| 7.3.3 | Stage Reassembly | 26 |
| 7.3.4 | Stage Testing..... | 28 |
| 7.3.5 | Machine Identification..... | 28 |
| 8 | Overhaul | 29 |
| 9 | Decommissioning | 29 |
| 9.1 | Dismantling and Disposal | 29 |
| 10 | Spare Parts | 30 |
| 11 | CAN Protocol | 31 |
| 11.1 | Standard CAN Interface 250 kBit/s..... | 31 |
| 11.2 | CAN Interface 500 kBit/s | 32 |
| 11.3 | CAN Interface 250 kBit/s, DOT Yellow | 32 |
| 11.4 | CAN Interface 250 kBit/s, DOT Red | 32 |
| 11.5 | CAN Interface 250 kBit/s, DOT Purple | 32 |
| 12 | Technical Data | 34 |
| 13 | TÜV Certificate | 35 |
| 14 | EU Declaration of Conformity | 36 |
| 15 | UK Declaration of Conformity | 37 |

1 Safety

Prior to handling the machine, this instruction manual should be read and understood. If anything needs to be clarified, please contact your Busch representative.

Read this manual carefully before use and keep for future reference.

This instruction manual remains valid as long as the customer does not change anything on the product.

The machine is intended for industrial use. It must be handled only by technically trained personnel.

Always wear appropriate personal protective equipment in accordance with the local regulations.

The machine has been designed and manufactured according to state-of-the-art methods. Nevertheless, residual risks may remain. This instruction manual highlights potential hazards where appropriate. Safety notes and warning messages are tagged with one of the keywords DANGER, WARNING, CAUTION, NOTICE and NOTE as follows:

DANGER

... indicates an imminent dangerous situation that will result in death or serious injuries if not prevented.

WARNING

... indicates a potentially dangerous situation that could result in death or serious injuries.

CAUTION

... indicates a potentially dangerous situation that could result in minor injuries.

NOTICE

... indicates a potentially dangerous situation that could result in damage to property.

NOTE

... indicates helpful tips and recommendations, as well as information for efficient and trouble-free operation.

2 Product Description

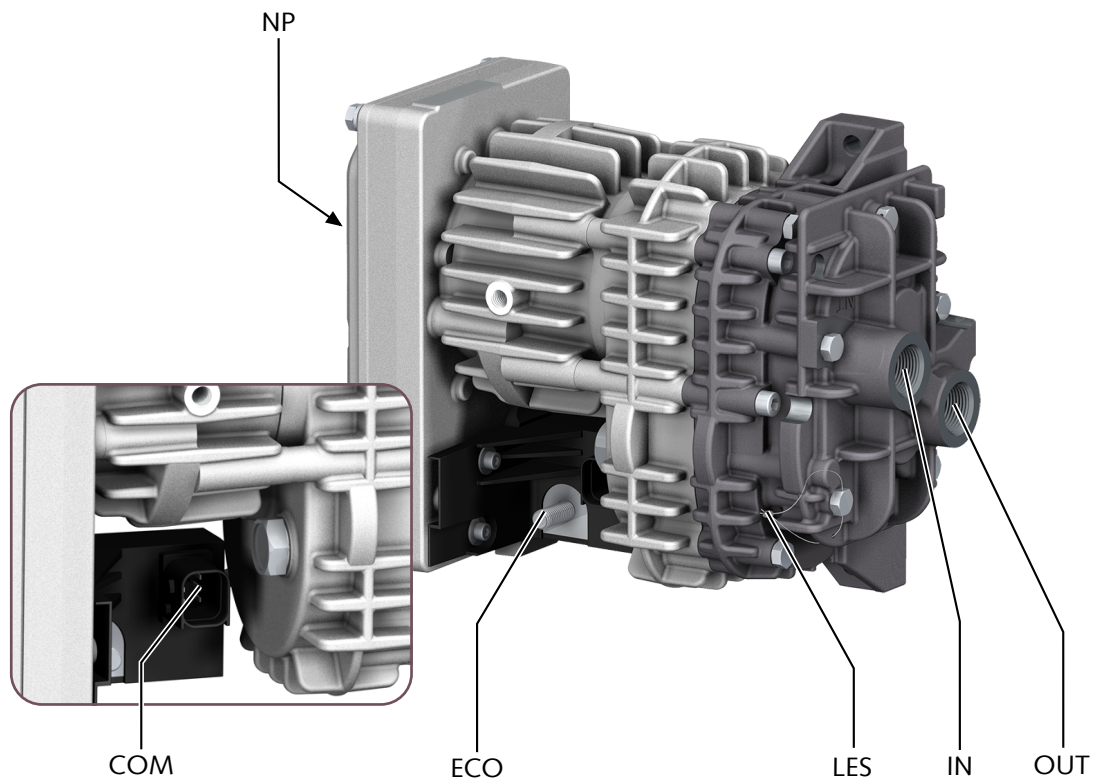

| | | | |
|-----|------------------------------|-----|---|
| COM | 6-pole HDSCS connector (CAN) | ECO | Electrical connection (+V _{Batt}) |
| IN | Inlet connection | LES | Lead seal |
| NP | Nameplate | OUT | Pressure connection |

NOTE

Technical term.

In this instruction manual, we consider that the term 'machine' refers to the 'compressor'.

NOTE

Illustrations

In this instruction manual the illustrations may differ from the machine appearance.

2.1 Operating Principle

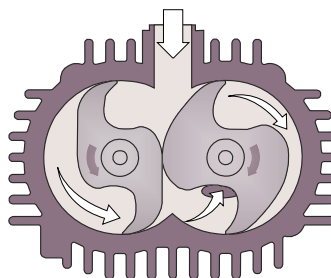

The machine works on the claw principle.

2.2 Application

The machine is intended for the recirculation of hydrogen gases or gas mixtures of nitrogen/humid hydrogen.

The machine is intended to be used with a water separator upstream of the suction connection. Liquid water permanently flowing through the process chamber will reduce its lifetime in a proportion linked to the amount of that liquid water.

Conveying of other media leads to an increased thermal and/or mechanical load on the machine and is permissible only after a consultation with Busch.

The machine is intended for the placement in a non-potentially explosive environment.

The machine is suitable for continuous operation.

Permitted environmental conditions, see Technical Data [► 34].

3 Transport

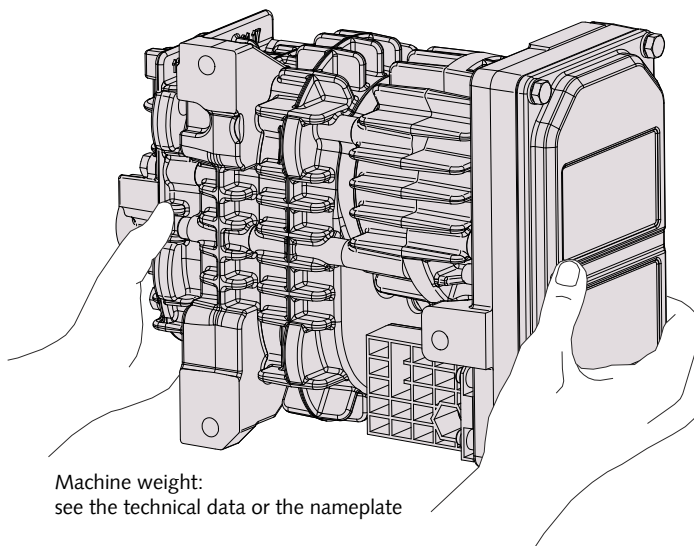

Machine weight:
see the technical data or the nameplate

- Check the machine for transport damage.

If the machine is secured to a base plate:

- Remove the machine from the base plate.

4 Storage

- Seal all apertures with adhesive tape or reuse provided caps, if not connected to a system.

If the machine is to be stored for more than 2 months:

- Make sure that the inside of the process chamber will be kept dry and dust free at ambient temperature.
- Before restarting the machine after a long period of machine shutdown, it is recommended to maintain as described in chapter Oil Draining [► 16].

5 Installation

5.1 Installation Conditions

WARNING

Hydrogen leaks.

Risk of severe injury!

Risk of explosion!

- Perform a hydrogen leak test of the entire system in order to fulfil a maximum leak rate of 10 Ncm³/h.
- Please refer to the Commission Regulation (EU) No 406/2010 and the Regulation (EU) No 79/2009.
- Make sure the machine is vented enough or monitored by a hydrogen sensor.
- Make sure that no excess pressure of more than 1.8 bar(a) reaches the machine inlet.

NOTICE

Use of the machine outside of the permitted installation conditions.

Risk of premature failure!

Loss of efficiency!

- Take care that the installation conditions are fully complied with.

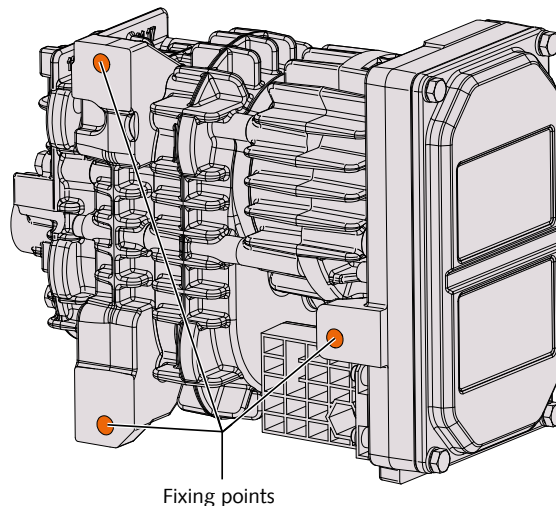

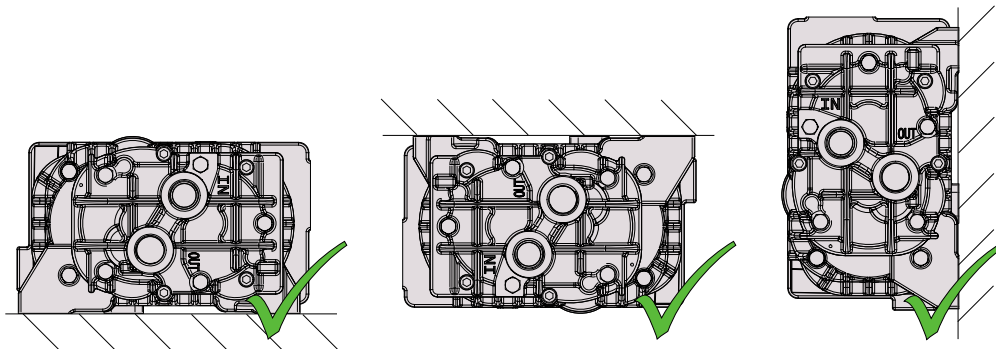

- Make sure that the environment of the machine is not potentially explosive.
- Make sure that the ambient conditions comply with the Technical Data [▶ 34].
- Make sure that the machine surface is clean from dust and dirt to guarantee an efficient cooling.
- Make sure that the installation space or location is vented such that sufficient cooling of the machine is provided.
- We strongly recommend to install the product at the top level of the fluid circuit to avoid the stagnation of condensates inside the compression stage.
- Make sure that all provided covers, guards, hoods, etc. are mounted.

WARNING

Vibration level.

Risk of premature failure!

- Make sure the product is protected from external shocks. Regarding vibration level, please contact your Busch representative to discuss the corresponding levels.

5.2 Connecting Lines / Pipes

WARNING

Unprotected connection.

Risk of severe injury!

- Do not put hand or fingers in the connection.
- Remove all protective covers before installation.
- Make sure that the connection lines cause no stress on the machine's connection; if necessary use flexible joints.
- Make sure that the line size of the connection lines over the entire length is at least as large as the connections of the machine.

In case of long connection lines it is advisable to use larger line sizes in order to avoid a loss of efficiency. Seek advice from your Busch representative.

- Make sure that the connections are "face sealed" and not "thread sealed" to ensure tightness.

5.2.1 Suction Connection

WARNING

Unprotected connection.

Risk of severe injury!

- Do not put hand or fingers in the connection.

NOTICE

Inlet gas particle size.

Risk of damage to the machine!

- Make sure that the inlet gas complies with ISO 12103-1, A.2 fine test dust.

NOTICE

Ingress of foreign objects or liquids.

Risk of damage to the machine!

If the inlet gas contains dust or other foreign solid particles:

- Install a suitable filter (5 micron or less) upstream from the machine.

Connection size(s):

- G1/2

Depending on the specific order, other connection dimensions may apply.

- Make sure that the gas is drawn without obstruction.
- Provide a water separator upstream of the suction connection. Liquid water permanently flowing through the process chamber will reduce its lifetime in a proportion linked to the amount of that liquid water.

5.2.2 Discharge Connection

WARNING

Unprotected connection.

Risk of severe injury!

- Do not put hand or fingers in the connection.

Connection size(s):

- G1/2

Depending on the specific order, other connection dimensions may apply.

- Make sure that the discharged gas will flow without obstruction. Do not shut off or throttle the discharge line.

5.3 Electrical Connection

DANGER

Live wires.

Risk of electrical shock.

- Electrical installation work must only be executed by qualified personnel.
- Make sure that the motor of the machine will not be affected by electric or electromagnetic disturbance from the mains; if necessary seek advice from Busch.
- Electrically connect the machine
- Make sure the resistance between the compressor and the grounded case is $R \geq 50 \text{ k}\Omega$ (e.g. rubber feet)
- Make sure that the resistance between compressor and connected lines is $R \geq 50 \text{ k}\Omega$ (e.g. hoses with resistance)

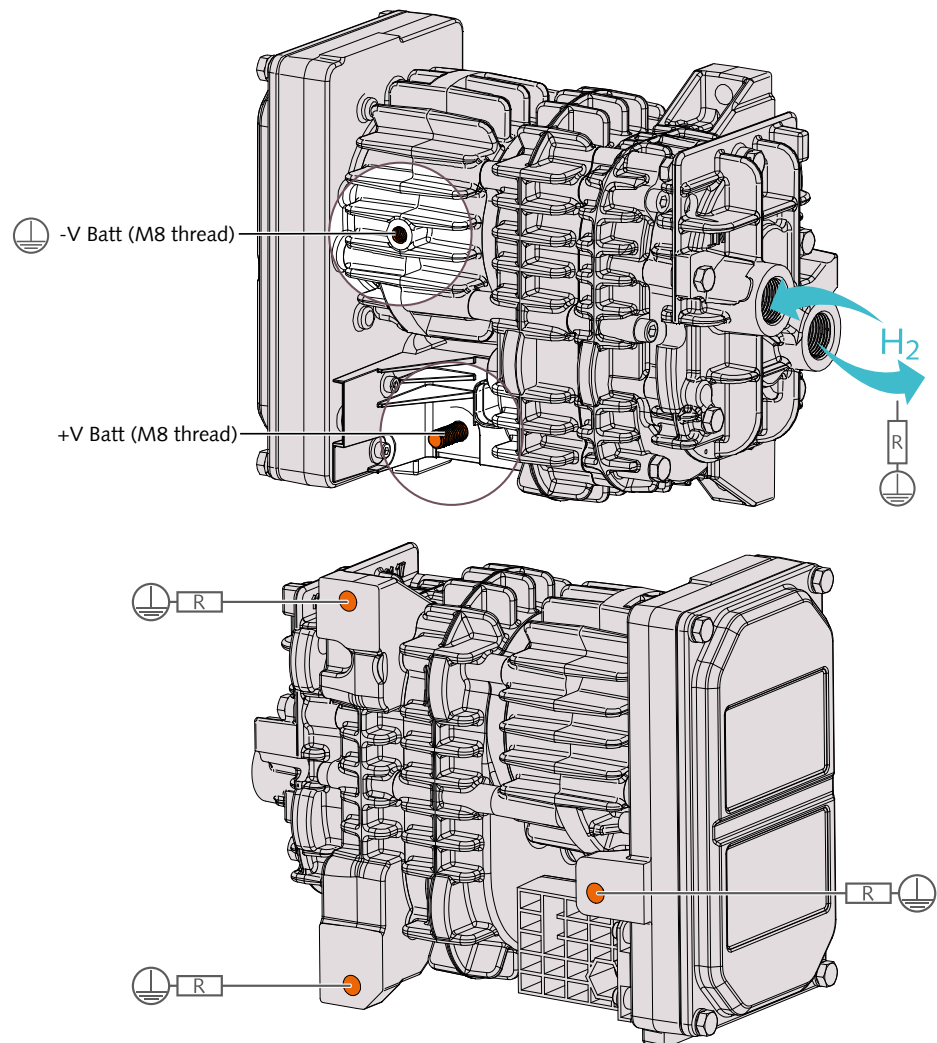

5.3.1 Version with Analogue Speed Control

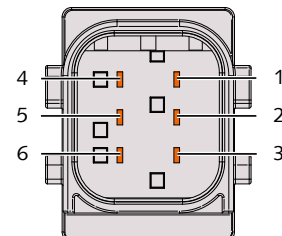
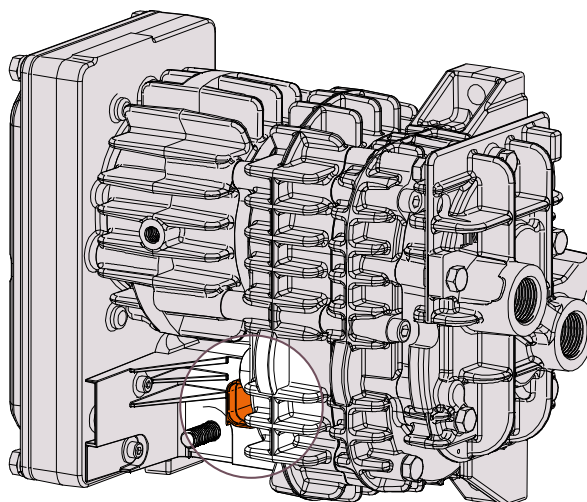

| | |
|----------------------------------|-------|
| 1 = 0 ... 5 V (= 0 ... 6600 rpm) | 4 = - |
| 2 = - | 5 = - |
| 3 = - | 6 = - |

5.3.2 Version with CAN-Communication

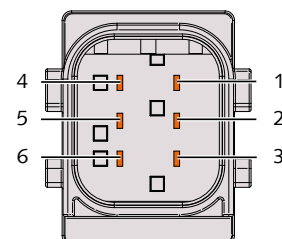
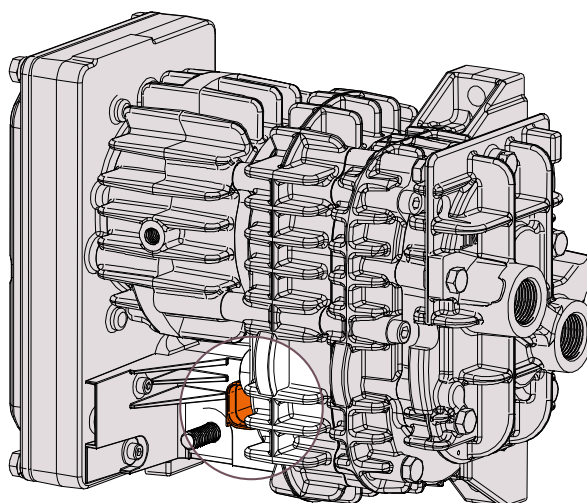

| | |
|---------------------|-------|
| 1 = KL15 (20-32VDC) | 4 = - |
| 2 = CAN H | 5 = - |
| 3 = CAN L | 6 = - |

i NOTE

If KL15 cable (pin 1 of the CAN connector) and CAN cable are longer than 30 meters.

Risk of electromagnetic disturbances!

- Make sure that the length of each cable does not exceed 30 meters.

5.3.3 Motor Rotation Direction

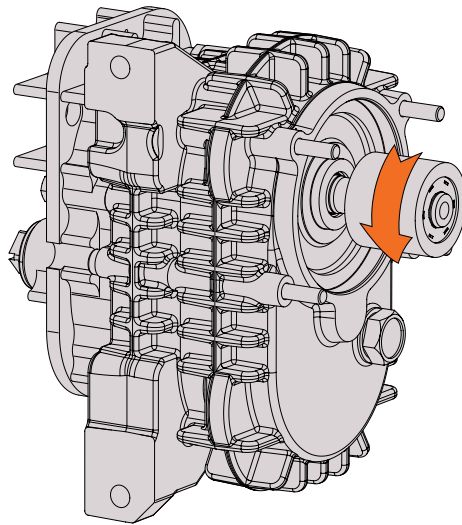

6 Commissioning

! NOTICE

Lubricating a dry running machine (compression chamber).

Risk of damage to the machine!

- Do not lubricate the compression chamber of the machine with oil or grease.

! CAUTION

During operation the surface of the machine may reach temperatures of more than 70°C.

Risk of burns!

- Avoid contact with the machine during and directly after operation.



! CAUTION

Noise of running machine.

Risk of damage to hearing!

If persons are present in the vicinity of a non noise insulated machine over extended periods:

- Make sure that ear protection is being used.
- Make sure that the installation conditions (see Installation Conditions [► 6]) are met.
- Switch on the machine.
- Make sure that the operating conditions comply with the Technical Data [► 34].

As soon as the machine is operated under normal operating conditions:

- Measure the motor current and record it as reference for future maintenance and troubleshooting work.

6.1 Standard Version

The machine starts automatically with maximum speed as soon as electrical power is supplied.

6.2 Version with Analogue Speed Control

The electronic is automatically activated as soon as electrical power is supplied.

The speed can be controlled by a potentiometer connected to terminal 1 (KL15) on the HDSC connector (CON).

Observe the following diagram to adjust the speed.

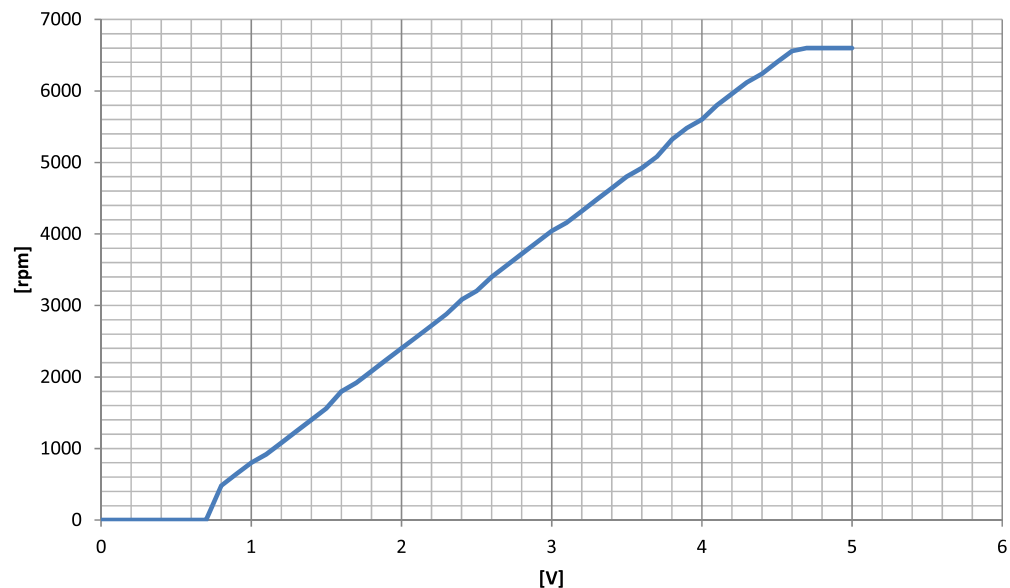

6.3 Version with CAN-Communication

The CAN communication and protocol are based on the following standards:

- ISO 11898 for hardware,
- SAE J1939 as vehicle standard for the software.

The CAN address coding is using the Intel protocol with Little Endian format.

The machine is controlled via CAN communication (see CAN Protocol [► 31]). The CAN control message send all necessary signals and reference values to the machine.

There are two different operating modes.

The speed control mode controls the speed of the machine.

The mass flow control mode controls the speed of the machine depending on the mass flow. For mass flow control mode the machine must be equipped with an air mass flow sensor. In case of a failure of the air mass flow sensor the machine switches automatically to speed control mode.

Terminal 1 (KL15)



The KL15 must be powered with the same voltage as the +Vbatt (20-32VDC with a nominal voltage of 24VDC).

High voltage level on terminal 1 (KL15) switches on the internal power supply of the machine. After switching on, the machine waits 10 seconds for a valid CAN control message before a CAN failure will be detected.

In case of a voltage level below 1.2V on terminal 1 (KL15) the machine decelerates to a speed of 1800 min⁻¹. After 10 seconds the machine stops. After further 2.5 seconds the internal power supply of the machine switches off.

CAN Status Message (Actual Values)

One second after startup, the machine sends every 50 ms a CAN status message with actual values. If the machine receives a CAN control message before the first second after startup the machine sends the CAN status message immediately.

Power-On Bit

After startup a power-on bit is set in the CAN status frame for one second. The power-on bit can be used to identify unexpected resets/restarts.

Loss of CAN Communication

If a loss of CAN communication occurs the reference value for mass flow will be set to 100 g/min. A loss of CAN communication will be detected if no valid CAN control message have been received for 500 ms. As soon as the CAN communication is available again the machine switches to normal operation immediately.

Speed reduction by temperature

The maximum speed of the machine depends on the electronic temperature to ensure safe operation of the machine at any temperatures.

The machine will reduce the speed if the electronic temperature is too high even if the reference speed value is higher than the actual speed. The speed reduction resulted from the electronic temperature is indicated by the sixth bit in the CAN status frame. There will be no indication on the sixth bit if the actual speed limited by the electronic temperature complies with the maximum speed.

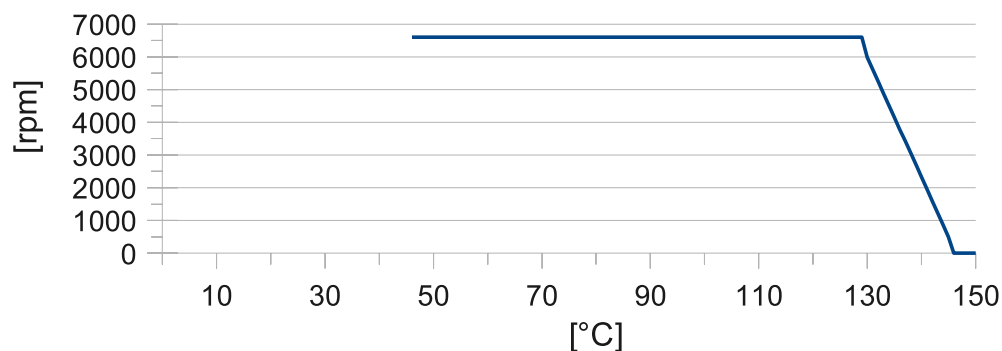

Loss of air mass flow sensor

At loss of the air mass flow sensor, the software switches automatically into the speed control mode with the predefined speed pre-control value.

Without or in case of loss of air mass flow sensor, the actual air temperature (given by the CAN Actual Values) is 214°C by default.

The loss of air mass flow sensor is visible in the CAN Status bit (see CAN Protocol). This failure is automatically reset as soon as new values are received from the air mass flow sensor. Without air mass flow sensor, the bit 2 of the diagnostics is automatically set to 1.

Over current protection

The electronics is protected against a blocked rotor or overload by an overcurrent protection. If an overcurrent is detected the motor stops immediately. The bit 7 "overcurrent" in the CAN Status frame is set for about 2 seconds.

One second after the stop of the motor the electronic tries to restart the motor automatically. If the overcurrent error occurs one more time, the motor stops again and the error bit in the can status frame stays on.

Plausibility check

A blocked rotor cannot be detected under all conditions by an overcurrent detection. Therefore, an additionally plausibility check is implemented.

The plausibility check checks different ratios inside the motor controller. If a plausibility check error occur the motor stops immediately and the bit 5 "plausibility error" in the CAN Status frame is set.

The timing for the error bit and the restart is identical to the overcurrent protection.

Electronics limits

| Status and diagnostic | Bit number | Limit |
|-----------------------|------------|--|
| Wrong voltage | 4 | 24 V motor ► 35 V |
| Speed derating | 6 | 130 ... 145 °C ► rotation speed decrease >145 °C ► motor off If Power Consumption permanently > 700W ► motor off |
| Overload | 6 and 7 | 700 W |

7 Maintenance



WARNING

Machines contaminated with hazardous material.

Risk of poisoning!

Risk of infection!

If the machine is contaminated with hazardous material:

- Wear appropriate personal protective equipment.

CAUTION

Hot surface.

Risk of burns!

- Prior to any action requiring touching the machine, let the machine cool down first.

NOTICE

Remove lead seal without Busch approval.

Loss of Busch liability!

- Ask your Busch representative before removing the lead seal.
- Shut down the machine and lock against inadvertent start up.
- Vent the connected lines to atmospheric pressure.

If necessary:

- Disconnect all connections.
- Separate special waste from the machine.
- Dispose of special waste in compliance with applicable regulations.
- Dispose of the machine as scrap metal.

7.1 Maintenance Schedule

The maintenance intervals depend very much on the individual operating conditions. The intervals given below are desired to be considered as starting values which should be shortened or extended as appropriate. Particularly harsh applications such as high liquid water content in the process gas, other contamination or ingress of process material, can make it necessary to shorten the maintenance intervals significantly.

The following maintenance schedule has been defined as information according to internal tests performed at Busch.

NOTE

Final maintenance schedule.

The final maintenance schedule must be committed between customers and Busch, based on field test results and analysis.

| Interval | Maintenance work |
|---|--|
| Every 5000 to 6000 hours, at the latest after 6 years | <ul style="list-style-type: none"> • Oil Draining [▶ 16] ⇒ If water content inside the gearbox lower than 30mL, replace the oil, see Oil Draining [▶ 16]. ⇒ If water content inside the gearbox higher than 30mL, replace the machine stage only, see Machine Stage Replacement [▶ 23]. |
| Every 12000 hours | <ul style="list-style-type: none"> • Replace the complete machine. |

7.2 Oil Draining

7.2.1 Overall Information

NOTE

Oil draining.

Recommendation.

- There is no ideal angle to put the gear for oil draining. We would recommend to move the gearbox several times from standard "vertical position" to a 90° position. The remaining oil must be the lowest possible.
- The illustration below shows the internal ribs and explains that there will always remain some oil inside.

Internal view of gearbox and oil output

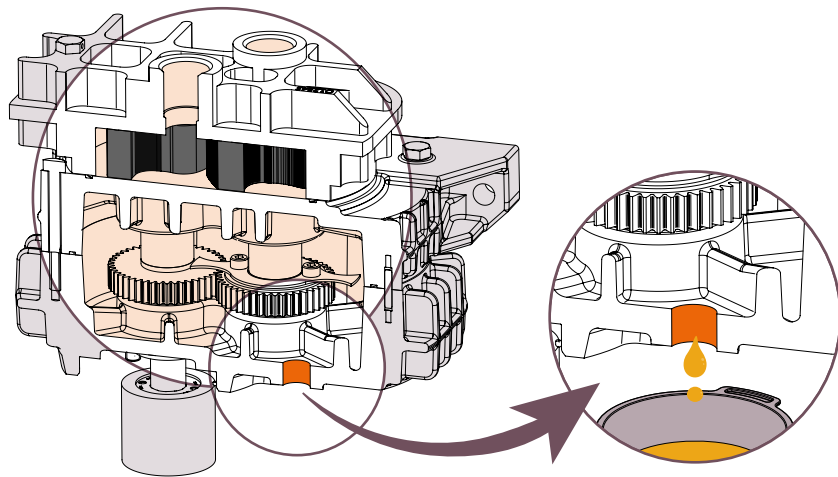

- The illustration below shows the "vertical position" for oil refilling.

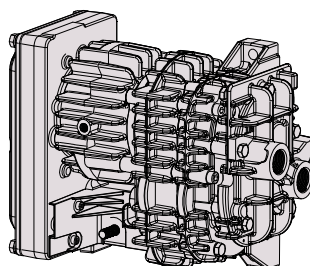

7.2.2 Draining Procedure

! NOTICE

Oil draining procedure.

Risk of damage to the machine!

- Before proceeding the oil draining, make sure that the cylinder of your machine has four access holes to the motor screws. If not, do not proceed the oil draining and contact your Busch representative.

STEP 1

- Remove the machine from the system.

STEP 2

- Use an M5 hexagonal tool to unscrew the four motor screws directly accessible through the four access holes of the cylinder.

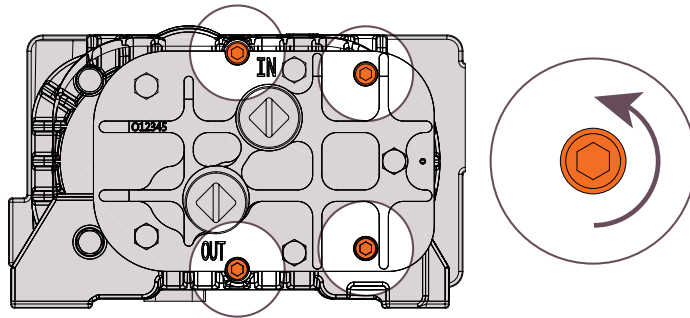

STEP 3

Removing the motor:

- Hold the motor while pulling up the stage (because of the resistance coming from the rotor's magnetic force).

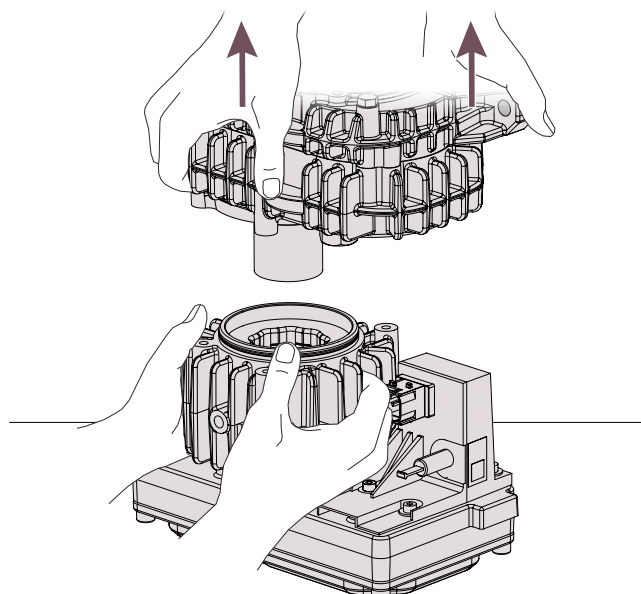

STEP 4

 **NOTE**

Oil draining.

Recommendation.

- There is no ideal angle to put the gear for oil draining. We would recommend to move the gearbox several times from standard "vertical position" to a 90° position. The remaining oil must be the lowest possible.

Oil draining and refilling

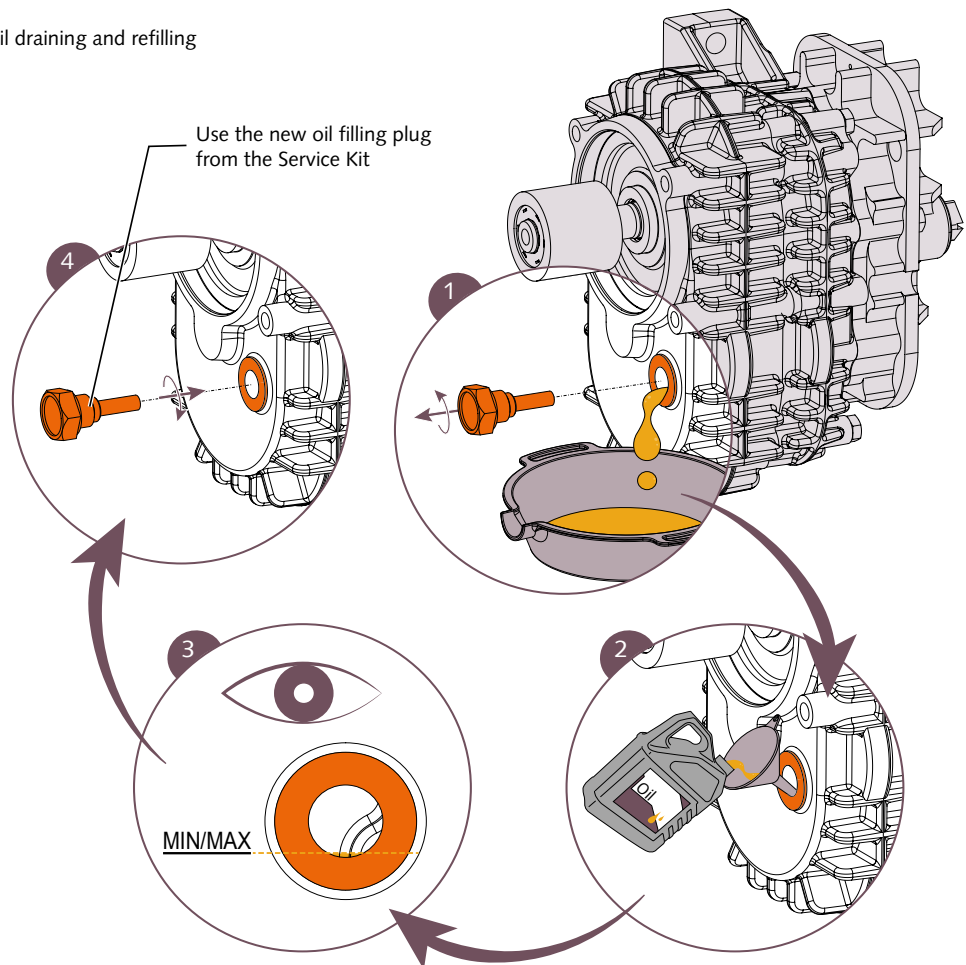

As shown in the illustration above:

- 1. Remove the oil filling plug and drain the oil.
- 2-3. With the machine in vertical position, refill with the new oil until the oil level is close to the lower edge of the oil draining/filling hole. The amount of oil required to refill is approximately 90 ml (see Service Kit and Oil Type [► 22] for the oil type to be used to refill).
- 4. Replace the old oil filling plug by the new one from the Service Kit (see Service Kit and Oil Type [► 22] for the service kit part number to be ordered) and tighten it with a **7 Nm screwing torque**.

STEP 5

- 1. Check the surface cleanliness for oil traces.

! NOTICE

Cleaning the surface.

Risk of damage to the machine!

- Do not use any solvent or liquid. Use only clean and dry paper or tissue!

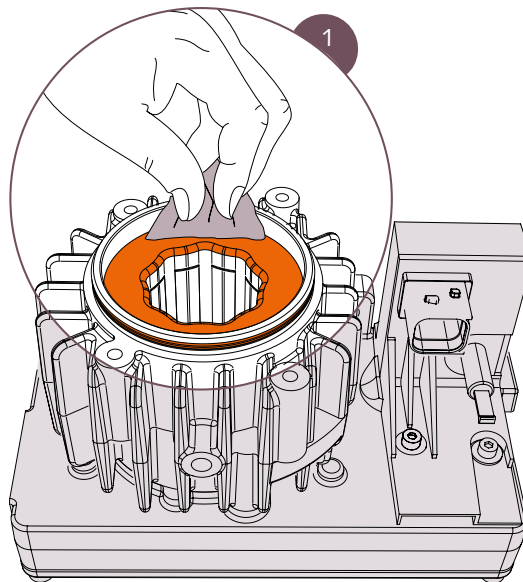

- 2. Remove the existing O-Ring carefully to avoid damaging the groove.

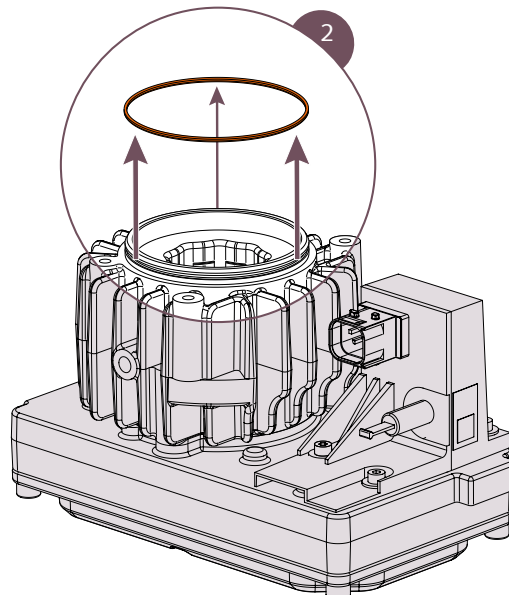

- Make sure there is no burr on machined surfaces (chamfer, groove, flange surface, etc.).

STEP 6

- Replace the old motor nose O-ring by the new one delivered in the kit. Put grease on it then place it correctly in its groove.

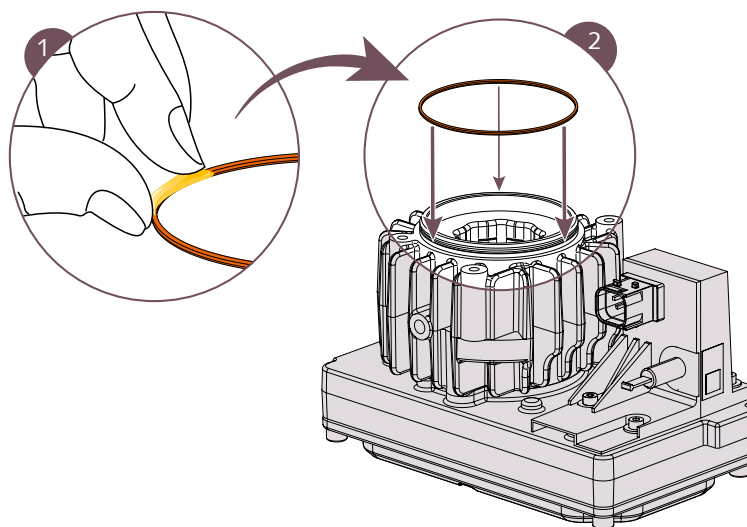

STEP 7

! NOTICE

Inserting the stage into the motor.

Risk of damage to the machine!

- Take care and make sure not to shock or bump the stage while inserting it into the motor!
- Insert gently the stage into the motor. Then insert and tighten the four M6 screws with a **5 Nm (+/-10%) screwing torque**.

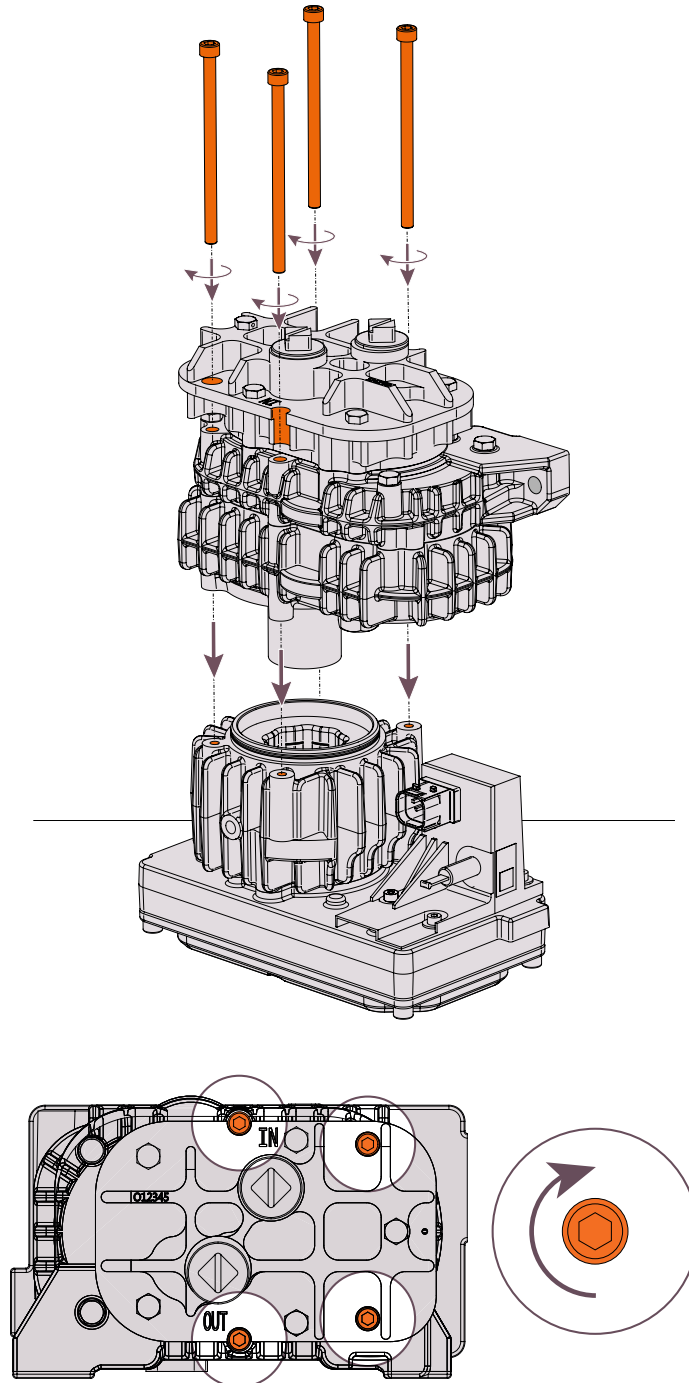

7.2.3 Service Kit and Oil Type

Service Kit

- Part number: 0990221163
- Content: Oil filling plug + Motor nose O-ring

Oil Type

| | VPA 032 |
|---------------------------|--------------|
| ISO-VG (Viscosity Class) | 32 |
| Base oil | PFPE |
| Part number 1 L packaging | 0831 237 294 |
| Part number 5 L packaging | 0831 237 295 |
| Applications | Fuel Cell |

Please consult your Busch representative for more details.

Oil has to be purchased locally by sales companies because of oil packaging.

7.2.4 Oil Troubleshooting

- Part numbers starting with 134123XXXX

| Problem | Remedy |
|---|--------------------------------------|
| Oil with less than 30mL of water inside gearbox | See Oil Draining [▶ 16] |
| Oil with more than 30mL of water inside gearbox | See Machine Stage Replacement [▶ 23] |

- Other part numbers

| Problem | Remedy |
|-----------|--------------------------------------|
| Black oil | See Machine Stage Replacement [▶ 23] |
| Grey oil | See Machine Stage Replacement [▶ 23] |

7.3 Machine Stage Replacement

7.3.1 Stage Disassembly

STEP 1

- If the cylinder has four holes to directly access to the motor screws, unscrew them using an M5 hexagonal tool and switch to STEP 4. If not, follow the instructions described on STEPS 2 and 3.

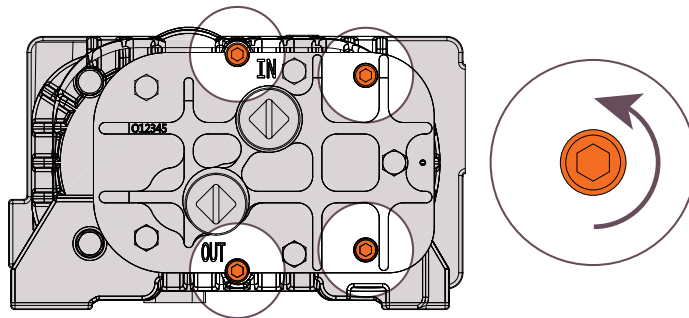

STEP 2

- If there is any, remove the plumbing (cut the wire) or the blue seal.

STEP 3

- 1. Remove the five M6 screws holding the cylinder and remove the cylinder.

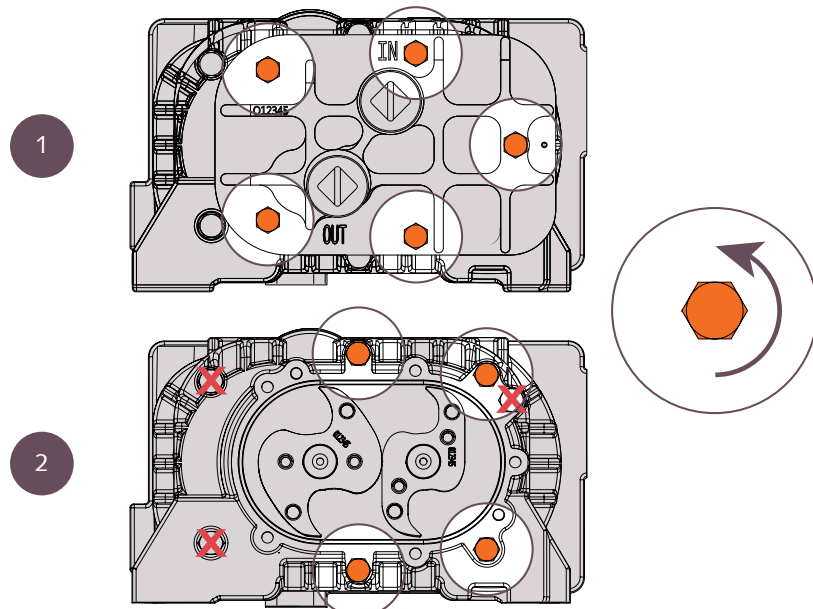

- 2. Then remove the four M6 screws holding the motor.
Do not unscrew the 3 other screws!

STEP 4

- Hold the motor while pulling up the stage (because of the resistance coming from the rotor's magnetic force).

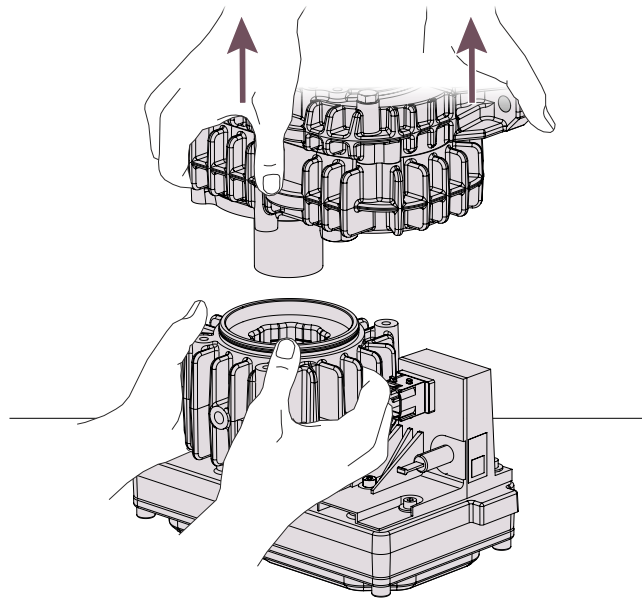

STEP 5

- 1. Check the surface cleanliness for oil traces.

! NOTICE

Cleaning the surface.

Risk of damage to the machine!

- Do not use any solvent or liquid. Use only clean and dry paper or tissue!

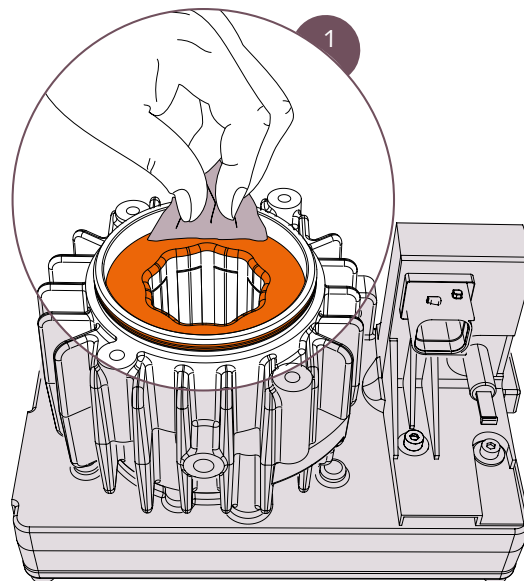

- 2. Remove the existing O-Ring carefully to avoid damaging the groove.

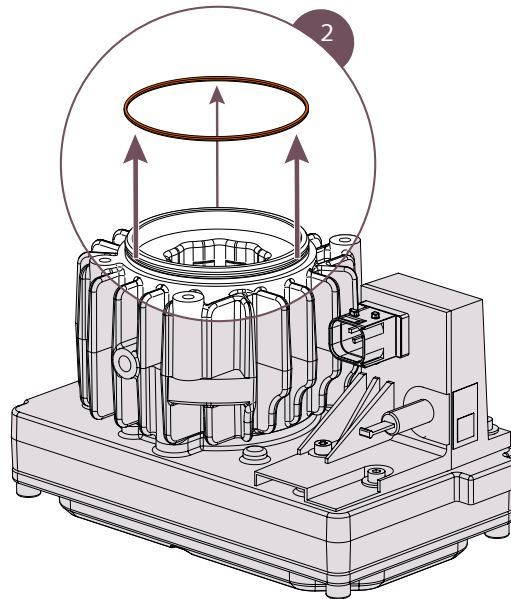

- Make sure there is no burr on machined surfaces (chamfer, groove, flange surface, etc.).

STEP 6

- Peel the label off (located on the backside of the motor). Do not use temperature higher than 100°C to help removing the label.
- Clean up the surface.

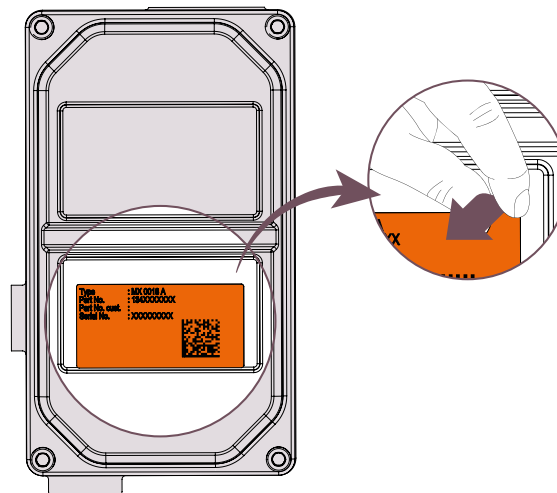

STEP 7

- To keep the traceability, report the former serial number in a dedicated file (such as an .xls file for instance) together with the dismounting date. Report as well the new serial number shown on the new identification label, see Stage Replacement Package [▶ 26]

7.3.2 Stage Replacement Package

The new stage is delivered with a kit in a plastic bag including a label with Serial Number. **This label must follow the stage to maintain the traceability.**

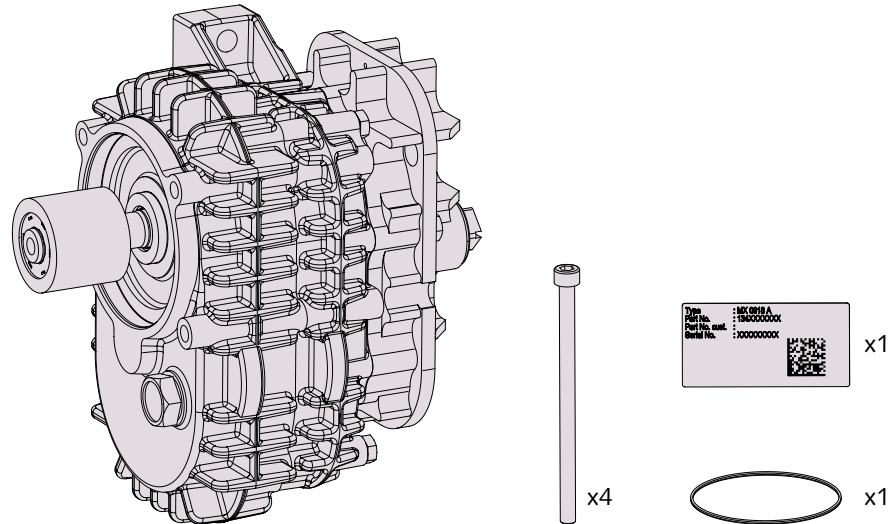

The plastic bag kit content is the following:

- M6 x 100 mm screws (x4),
- New identification label with new serial number (x1),
- Spare O-ring for motor nose (x1).

7.3.3 Stage Reassembly

STEP 1

- Place and stabilize the motor to be refurbished on an adapted positioning device.

STEP 2

- Replace the old motor nose O-ring by the new one delivered in the kit. Put grease on it then place it correctly in its groove.

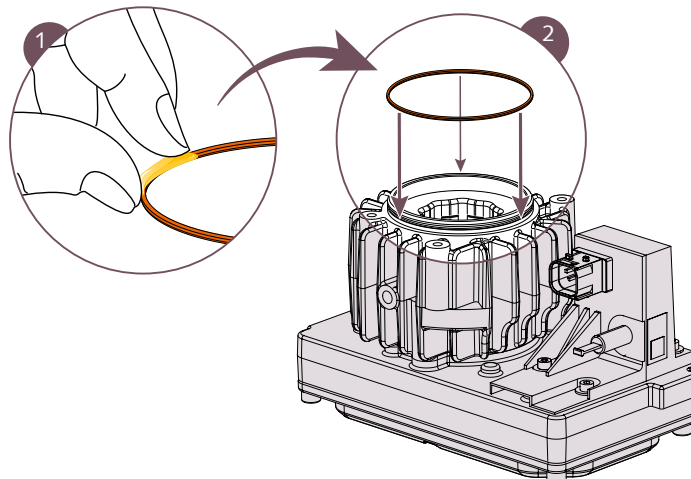

STEP 3

! NOTICE

Inserting the stage into the motor.

Risk of damage to the machine!

- Take care and make sure not to shock or bump the stage while inserting it into the motor!
- Insert gently the stage into the motor. Then insert and tighten the four M6 screws with a **5 Nm (+/-10%) screwing torque**.

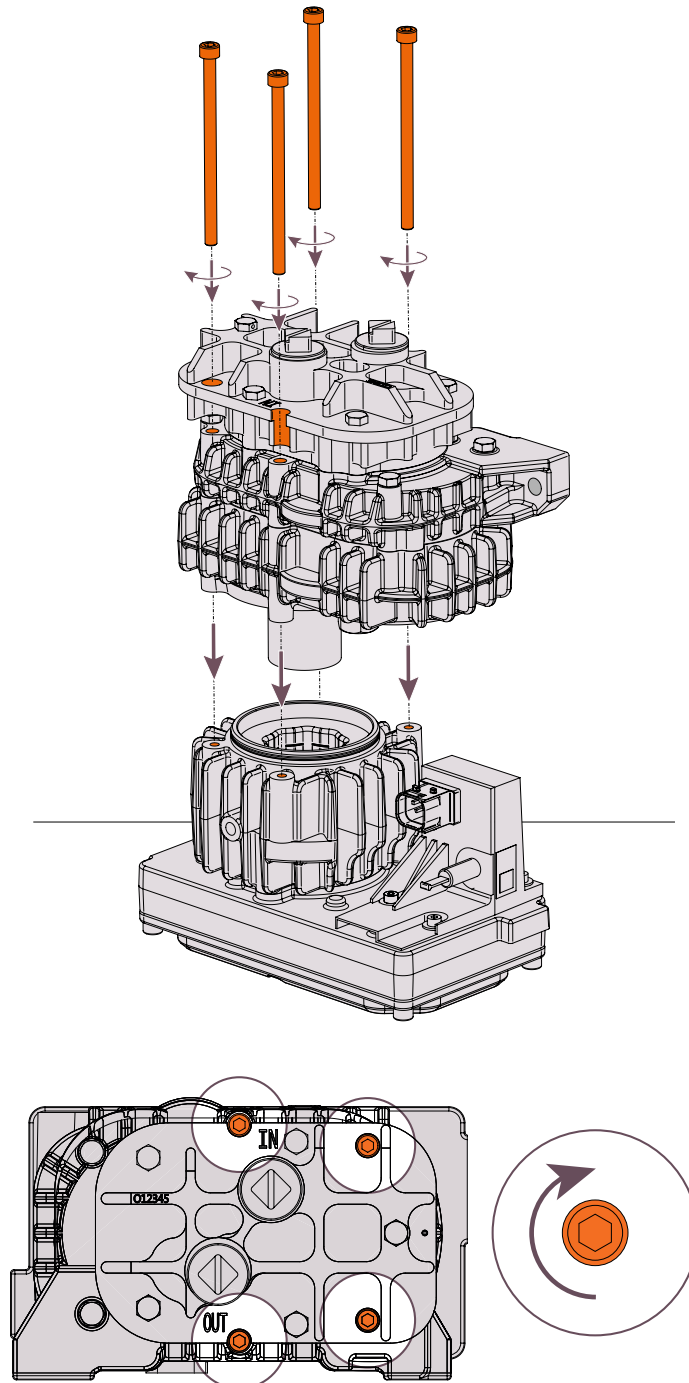

7.3.4 Stage Testing

Motor start test:

100% of stages are tested at the manufacturing company and performances are stored for traceability. This test intends to guarantee that the complete blower starts properly.

- Use a stabilized 500 Watts power supply.
- Plug the ground (black wire) on the motor housing. Plug the power (red wire) to the screw.
- Set the voltage to 24V and the current to maximum (the compressor will consume what it needs).
- Shut down the power after 10 seconds.

7.3.5 Machine Identification

Relabelling the pump with the new label contained in the kit package:

- Make sure that the serial number engraved on the gearbox cover of the machine is the same than the one on the new label (make sure the traceability was not lost).
- If the serial number is the same both on label and gearbox cover, stick the label on the motor side. If not, check pairing.

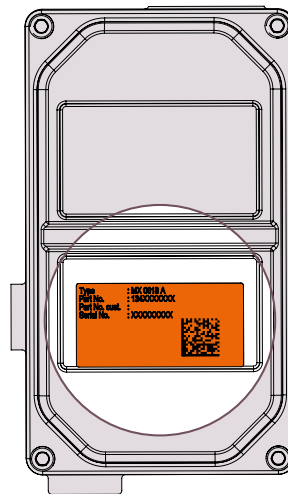

8 Overhaul



WARNING

Machines contaminated with hazardous material.

Risk of poisoning!

Risk of infection!

If the machine is contaminated with hazardous material:

- Wear appropriate personal protective equipment.

NOTICE

Improper assembly.

Risk of premature failure!

Loss of efficiency!

- It is highly recommended that any dismantling of the machine that goes beyond anything that is described in this manual should be done through Busch.

In case of the machine having conveyed gas that was contaminated with foreign materials which are dangerous to health:

- Decontaminate the machine as much as possible and state the contamination status in a 'Declaration of Contamination'.

Busch will only accept machines that come with a completely filled in and legally binding signed 'Declaration of Contamination' (form downloadable from www.buschvacuum.com).

9 Decommissioning

- Shut down the machine and lock against inadvertent start up.
- Vent the connected lines to atmospheric pressure.
- Disconnect all connections.

If the machine is going to be stored:

- See Storage.

9.1 Dismantling and Disposal

- Drain the oil.
- Separate special waste from the machine.
- Dispose of special waste in compliance with applicable regulations.
- Dispose of the machine as scrap metal.

10 Spare Parts

NOTICE

Use of non-Busch genuine spare parts.

Risk of premature failure!

Loss of efficiency!

- The exclusive use of Busch genuine spare parts and consumables is recommended for the correct functioning of the machine and to validate the warranty.
-

Standard spare parts kits are available for this product.

- For oil draining, see Service Kit and Oil Type [[▶ 22](#)].
- For stage replacement, see Stage Replacement Package [[▶ 26](#)].
- Please contact your Busch representative for further information.

11 CAN Protocol

11.1 Standard CAN Interface 250 kBit/s

| Transmit Control Unit | No. Control Unit | Message Name | Signal Name | Identifier | DLC | | Repetition Rate | Start Byte | | Bit Length | Signal Resolution | Signed/Unsigned Value | Offset | Signal Unit | Comments | Default Value | | | | |
|------------------------|------------------|---|---|---------------|----------|------|-----------------|----------------|------------|------------|-------------------|-----------------------|--------|---|----------|---------------|--|--|--|--|
| | | | | | Hex | Byte | | Dez | Dez | | | | | | | | | | | |
| EnCU | | Control Message | Mass Flow Setpoint | 0x0C FF A6 3D | 8 | 50 | 0 | 0 | 16 | 0.001 | Unsigned | 0 | kg/h | 0 - 64,265 kg/h | | | | | | |
| | | | Speed Setpoint | | | | 2 | 0 | 16 | 1.000 | Unsigned | 0 | U/min | 0 - 64255 U/min | | | | | | |
| | | | Enable Pump | | | | 4 | 0 | 2 | | Unsigned | 0 | | 00 - Disable Pump 01 - Enable Pump 11 - Not Available | | | | | | |
| PCU | | Actual Values | Enable Mass Flow Governor | 0x0C FF A7 B4 | 8 | 50 | 4 | 2 | 2 | | Unsigned | 0 | | 00 - Disable Mass Flow Governor 01 - Enable Mass Flow Governor 11 - Not Available | | | | | | |
| | | | Actual Mass Flow | | | | 0 | 0 | 16 | 0.002 | Unsigned | -60 | kg/h | -60-68.51 kg/h | | | | | | |
| | | | Actual Speed | | | | 2 | 0 | 8 | 40.000 | Unsigned | 0 | U/min | 0 - 10200 U/min | | | | | | |
| | | | Actual Current | | | | 3 | 0 | 8 | 0.500 | Unsigned | 0 | A | 0 - 125 A | | | | | | |
| | | | Actual Voltage | | | | 4 | 0 | 8 | 0.200 | Unsigned | 0 | V | 0 - 50 V | | | | | | |
| | | | Actual Electronic Temperature | | | | 5 | 0 | 8 | 1.000 | Unsigned | 0 | °C | -40 - 210 °C | | | | | | |
| | | | Actual Air Temperature | | | | 6 | 0 | 8 | 1.000 | Unsigned | -40 | °C | -40 - 210 °C | | | | | | |
| | | | Status and Diagnose Word (see below) | | | | 7 | 0 | 8 | | Unsigned | 0 | | see below | | | | | | |
| | | | Parameter Values | | | | 0x0C FF A8 3D | 8 | | | | | | | | | | | | |
| | | | Bm_IP1MassFlow_C | | | | 0 | 0 | 8 | 10.00 | Unsigned | 0 | ms | 0 - 2500 ms | 100 ms | | | | | |
| Bm_KpAirGvnr_C | 1 | 0 | 8 | 0.05 | Unsigned | 0 | 1/g | 0 - 12.7 | 1,25 1/g | | | | | | | | | | | |
| Bm_KiAirGvnr_C | 2 | 0 | 8 | 0.05 | Unsigned | 0 | 1/g | 0 - 12.7 | 2,6 1/g | | | | | | | | | | | |
| Bm_nSetErrorRepValue_C | 3 | 0 | 8 | 20.00 | Unsigned | 0 | U/min | 0 - 5000 U/min | 3120 U/min | | | | | | | | | | | |
| PCU | | Acknowledgment (according to SAE-J1939-21) | Acknowledge | 0x18 FF AB B4 | 8 | | 0 | 0 | 1 | | Unsigned | 0 | | 0 for Positive Acknowledge 1 for Negative Acknowledge | | | | | | |
| | | | Parameter Group Number of the Message, which needs an Acknowledge | | | | 5 | 0 | 24 | | Unsigned | 0 | | In this Case 'FF A8' | | | | | | |

| Bit-Timing | Status and Diagnose Word | Bit |
|-------------------|----------------------------|------|
| Baudrate | Status and Diagnose Word | bit0 |
| Time Quanta TQ: | Pump enabled | bit1 |
| Bit time | Mass Flow Governor enabled | bit2 |
| Sync. jump width | MAF Error | bit3 |
| Sample Point | PowerOn | bit4 |
| Number of samples | Wrong Voltage | bit5 |
| | Plausibility error | bit6 |
| | Speed derating | bit7 |
| | Over Current | |

11.2 CAN Interface 500 kBit/s

- Baudrate 500 kb/s
- Bit length 11 bit
- Behaviour at CAN loss: "0" RPM
- Enable signal for electronics activation "Yes"
- Motor behaviour when flow request "0" → "Motor waits for signal"
- CAN ID
 - Control message: 0x101
 - Parameter values: 0x103
 - Actual values: 0x102
 - Acknowledgement: 0x104

11.3 CAN Interface 250 kBit/s, DOT Yellow

- Baudrate 250 kb/s
- Bit length 29 bit
- Behaviour at CAN loss: "0" RPM
- Enable signal for electronics activation "No"
- Motor behaviour when flow request "0" → "Motor waits for signal"
- CAN ID
 - Control message: 0x0C FF A6 3D
 - Parameter values: 0x0C FF A8 3D
 - Actual values: 0x0C FF A7 B4
 - Acknowledgement: 0x18 FF AB B4

11.4 CAN Interface 250 kBit/s, DOT Red

- Baudrate 250 kb/s
- Bit length 29 bit
- Behaviour at CAN loss: "0" RPM
- Enable signal for electronics activation "No"
- Motor behaviour when flow request "0" → "Motor waits for signal"
- CAN ID
 - Control message: 0x0C FF A6 3F
 - Parameter values: 0x0C FF A8 3F
 - Actual values: 0x0C FF A7 B6
 - Acknowledgement: 0x18 FF AB B6

11.5 CAN Interface 250 kBit/s, DOT Purple

- Baudrate 250 kb/s
- Bit length 29 bit
- Behaviour at CAN loss: "0" RPM
- Enable signal for electronics activation "No"
- Motor behaviour when flow request "0" → "Motor waits for signal"
- CAN ID
 - Control message: 0x0C FF A6 4D
 - Parameter values: 0x0C FF A8 4D
 - Actual values: 0x0C FF A7 C4
 - Acknowledgement: 0x18 FF AB C4

12 Technical Data

| | | MH 0018 A |
|--|---------------------|--|
| Nominal max. pumping speed | m ³ /h | 18 |
| Overpressure | bar(g) | 0.4 max. |
| Admissible inlet pressure | bar(a) | from ambient to 1.8 max. |
| Nominal motor rating | kW | 0.5 |
| Nominal motor voltage | V DC | 24 (20-32) |
| Permitted motor speed range | min ⁻¹ | 480 ... 6000 |
| Noise level (EN ISO 2151) at 3000 / 6000 min ⁻¹ | dB(A) | 68 / 73 (inlet and outlet connected to a system) |
| Inlet gas temperature range | °C | -30 ... +85 |
| Ambient temperature range | °C | -30 ... +95 |
| Leak rate (EU 79/2009 & 406/2010) | Ncm ³ /h | <10 |
| Ambient pressure | | Atmospheric pressure |
| Oil capacity | mL | 100 0/+5 |
| Oil leak rate | mL/1000hours | 5 |
| Dimensions | mm | 249.5 x 120 x 199 |
| Weight approx. | kg | 6.5 |

High frequency transient phases (with up and down pressure levels) need to be discussed and validated between customers and Busch on applications themselves.

13 TÜV Certificate



Confirmation
P0EU0003-00



Confirmation

SGS-TÜV Saar GmbH

Kraftfahrt-Bundesamt (KBA),
Federal Republic of Germany

notified by
National Standards
Authority of Ireland (NSAI)

Rijksdienst voor het Wegver-
keer (RDW),
The Netherlands
No. 99050064 00

No. KBA - P 00084 – 10

No. 101

confirms for manufacturer

Ateliers Busch S.A.
Zone Industrielle
2906, Chevenez (Switzerland)



that the hydrogen recirculation blower of

Type: MH 0018 A
Make: Mink

is in compliance with the required safety level of the test standard

Regulation (EC) 79/2009
(Annex V including Regulation (EU) 406/2010)
Hydrogen components, other than containers,
designed to use compressed (gaseous) hydrogen

and suitable for the use in automotive hydrogen applications. For details and restrictions refer to SGS-TÜV Saar GmbH Laboratory Report P0EU0002-00 of Aug 28, 2019.

Munich, Aug 28, 2019

Responsible expert

Conformity check

Bastian Babin

Karim Kortländer

This Confirmation shall be reproduced and published in full only and by the client only.
It shall be reproduced partially with the written permission of the Test Laboratory only.

This document is issued by the Company subject to its General Conditions of Service (www.sgsgroup.de/agb). Attention is drawn to the limitations of liability, indemnification and jurisdictional issues established therein. This document is an original. If the document is submitted digitally, it is to be treated as an original within the meaning of UCP 600. Any holder of this document is advised that information contained hereon reflects the Company's findings at the time of its intervention only and within the limits of client's instructions, if any. The Company's sole responsibility is to its Client and this document does not exonerate parties to a transaction from exercising all their rights and obligations under the transaction documents. Any unauthorized alteration, forgery or falsification of the content or appearance of this document is unlawful and offenders may be prosecuted to the fullest extent of the law.

SGS-TÜV Saar GmbH | Am TÜV 1 | D-66280 Sulzbach | t +49 6897 506 - 60 | f +49 6897 506 - 102 | www.sgs-tuev-saar.com

Member of the SGS Group (Société Générale de Surveillance)

Alle Dienstleistungen werden auf Grundlage der anwendbaren Allgemeinen Geschäftsbedingungen der SGS, die auf Anfrage zur Verfügung gestellt werden, erbracht.
Die Veröffentlichung und Vervielfältigung unserer Prüfberichte und Gutachten zu Werbezwecken sowie deren auszugsweise Verwendung in sonstigen Fällen bedürfen unserer schriftlichen Genehmigung.
Geschäftsführer: Stefan Steinhardt, Sitz der Gesellschaft: Sulzbach, HRB 977 Amtsgericht Saarbrücken

Page
1 of 1

14 EU Declaration of Conformity

This Declaration of Conformity and the CE-mark affixed to the nameplate are valid for the machine within the Busch scope of delivery. This Declaration of Conformity is issued under the sole responsibility of the manufacturer. When this machine is integrated into a superordinate machinery the manufacturer of the superordinate machinery (this can be the operating company, too) must conduct the conformity assessment process for the superordinate machine or plant, issue the Declaration of Conformity for it and affix the CE-mark.

The manufacturer **Ateliers Busch S.A.**
Zone Industrielle
CH-2906 Chevenez

declares that the machine(s): **MINK MH 0018 A**

fulfil(s) all the relevant provisions from European directives:

- 'Machinery' 2006/42/EC
- 'Electromagnetic Compatibility' 2014/30/EU
- 'RoHS' 2011/65/EU Restriction of the use of certain hazardous substances in electrical and electronic equipment (incl. all related applicable amendments)

and comply(-ies) with the following designated standards that have been used to fulfil those provisions:

| Standard | Title of the Standard |
|--|---|
| EN ISO 12100 : 2010 | Safety of machinery - Basic concepts, general principles of design |
| EN ISO 13857 : 2019 | Safety of machinery - Safety distances to prevent hazard zones being reached by the upper and lower limbs |
| EN 1012-1 : 2010 EN 1012-2 : 1996 + A1 : 2009 | Compressors and vacuum pumps - Safety requirements - Part 1 and Part 2 |
| EN ISO 2151 : 2 : 2008 | Acoustics - Noise test code for compressors and vacuum pumps - Engineering method (grade 2) |
| EN IEC 60204 : 2019 | Safety of machinery - Electrical equipment of machines - Part 1: General requirements |
| EN IEC 61000-6-2 : 2019 | Electromagnetic compatibility (EMC) - Generic standards. Immunity for industrial environments |
| EN IEC 61000-6-4 : 2019 | Electromagnetic compatibility (EMC) - Generic standards. Emission standard for industrial environments |
| EN ISO 13849-1 : 2015 ⁽¹⁾ | Safety of machinery - Safety-related parts of control systems - Part 1: General principles for design |

⁽¹⁾ In case control systems are integrated.

Legal person authorized to compile the technical file
 and authorized representative in the EU
 (if the manufacturer is not located in the EU):

Busch Dienste GmbH
 Schauinslandstr. 1
 DE-79689 Maulburg

Chevenez, 14.05.2021



Christian Hoffmann, General Director

15 UK Declaration of Conformity

This Declaration of Conformity and the UKCA-mark affixed to the nameplate are valid for the machine within the Busch scope of delivery. This Declaration of Conformity is issued under the sole responsibility of the manufacturer. When this machine is integrated into a superordinate machinery the manufacturer of the superordinate machinery (this can be the operating company, too) must conduct the conformity assessment process for the superordinate machine or plant, issue the Declaration of Conformity for it and affix the UKCA-mark.

The manufacturer

**Ateliers Busch S.A.
Zone Industrielle
CH-2906 Chevenez**

declares that the machine(s): **MINK MH 0018 A**

fulfil(s) all the relevant provisions from UK legislations:

- Supply of Machinery (Safety) Regulations 2008
- Electromagnetic Compatibility Regulations 2016
- Restriction of the use of certain hazardous substances in electrical and electronic equipment Regulations 2012

and comply(-ies) with the following designated standards that have been used to fulfil those provisions:

| Standard | Title of the Standard |
|--|--|
| BS EN ISO 12100 : 2010 | Safety of machinery. Basic concepts, general principles of design. Risk assessment and risk reduction. |
| BS EN ISO 13857 : 2019 | Safety of machinery - Safety distances to prevent hazard zones being reached by the upper and lower limbs. |
| BS EN 1012-1 : 2010 BS EN 1012-2 : 1996 + A1 : 2009 | Compressors and vacuum pumps. Safety requirements. Air compressors and vacuum pumps. |
| BS EN ISO 2151 : 2 : 2008 | Acoustics - Noise test code for compressors and vacuum pumps - Engineering method (grade 2) |
| BS EN 60204-1 : 2018 | Safety of machinery. Electrical equipment of machines. General requirements. |
| BS EN IEC 61000-6-2 : 2019 | Electromagnetic compatibility (EMC) - Generic standards. Immunity standard for industrial environments. |
| BS EN IEC 31000-6-4 : 2019 | Electromagnetic compatibility (EMC) - Generic standards. Emission standard for industrial environments. |
| BS EN 13849-1 : 2015 ⁽¹⁾ | Safety of machinery. Safety-related parts of control systems. General principles for design. |

⁽¹⁾ In case control systems are integrated.

Legal person authorized to compile the technical file
and importer in the UK
(if the manufacturer is not located in the UK):

Busch (UK) Ltd
30 Hortonwood
Telford - UK

Chevenez, 14.05.2021



Christian Hoffmann, General Director

Note

A large, empty rectangular box with a thin gray border, occupying most of the page below the 'Note' header. It is intended for the user to write their notes.

A large, empty rectangular box with a thin grey border, occupying most of the page below the 'Note' header. It is intended for the user to write their notes.

Busch

Vacuum Solutions

We shape vacuum for you.

Argentina

info@busch.com.ar

Australia

sales@busch.com.au

Austria

busch@busch.at

Bangladesh

sales@busch.com.bd

Belgium

info@busch.be

Brazil

vendas@buschdobrasil.com.br

Canada

info@busch.ca

Chile

info@busch.cl

China

info@busch-china.com

Colombia

info@buschvacuum.co

Czech Republic

info@buschvacuum.cz

Denmark

info@busch.dk

Finland

info@busch.fi

France

busch@busch.fr

Germany

info@busch.de

Hungary

busch@buschvacuum.hu

India

sales@buschindia.com

Ireland

sales@busch.ie

Israel

service_sales@busch.co.il

Italy

info@busch.it

Japan

info@busch.co.jp

Korea

busch@busch.co.kr

Malaysia

busch@busch.com.my

Mexico

info@busch.com.mx

Netherlands

info@busch.nl

New Zealand

sales@busch.co.nz

Norway

post@busch.no

Peru

info@busch.com.pe

Poland

busch@busch.com.pl

Portugal

busch@busch.pt

Romania

office@buschromania.ro

Russia

info@busch.ru

Singapore

sales@busch.com.sg

South Africa

info@busch.co.za

Spain

contacto@buschiberica.es

Sweden

info@busch.se

Switzerland

info@buschag.ch

Taiwan

service@busch.com.tw

Thailand

info@busch.co.th

Turkey

vakutek@ttmail.com

United Arab Emirates

sales@busch.ae

United Kingdom

sales@busch.co.uk

USA

info@buschusa.com