

# Instruction Manual

## VACTEST

Vacuum Measurement Equipment  
Digital Transmitter DPH 400



Get technical data,  
instruction manuals,  
service kits



# Table of Contents

<b>1</b>	<b>Safety</b> .....	<b>3</b>
<b>2</b>	<b>Product Description</b> .....	<b>4</b>
2.1	Interface Illustration .....	4
2.2	Product Identification .....	4
2.3	Delivery Content .....	4
2.4	Proper Use .....	4
2.5	Improper Use .....	4
<b>3</b>	<b>Transport and Storage</b> .....	<b>5</b>
<b>4</b>	<b>Installation</b> .....	<b>5</b>
4.1	Installation Conditions .....	5
4.2	Vacuum Connection.....	5
4.3	Electrical Connection .....	7
4.3.1	Connecting to the Active Sensor Controller .....	7
4.3.2	Connecting to the USB/RS485 Converter .....	8
4.3.3	I/O and Communication Port Schematic .....	9
4.4	Change Display Unit and Orientation (Display version only).....	10
<b>5</b>	<b>Operation</b> .....	<b>10</b>
5.1	Before Operation .....	10
5.2	Operating the Gauge .....	11
5.2.1	Operating Flowchart .....	12
5.3	Setpoints .....	13
5.4	Degas.....	13
5.4.1	Degas Control by Pushbutton.....	14
5.4.2	Degas Control by External Voltage Signal .....	14
5.4.3	Degas Control via Software Command .....	14
5.4.4	Degas Control via Controller .....	14
5.5	Bake-out .....	15
5.6	Readjustment .....	15
5.6.1	Readjustment by Pushbutton.....	15
5.6.2	Readjustment via Software Command .....	16
5.6.3	Readjustment via Controller .....	16
<b>6</b>	<b>Communication</b> .....	<b>17</b>
6.1	Setting RS485 Address .....	17
6.2	Commands Overview.....	18
6.2.1	Setpoints .....	20
6.2.2	Readjustment .....	20
6.2.3	Degas.....	21
6.2.4	Sensor Transition .....	21
6.2.5	Ionization Sensor .....	22
6.3	VacTest Explorer Software.....	23
<b>7</b>	<b>Maintenance and Service</b> .....	<b>23</b>
7.1	Replacing the Sensor Head .....	24
<b>8</b>	<b>Troubleshooting</b> .....	<b>24</b>
<b>9</b>	<b>Spare Parts and Accessories</b> .....	<b>25</b>
<b>10</b>	<b>Technical Data</b> .....	<b>26</b>
10.1	Gas Correction Factor.....	27
<b>11</b>	<b>EU Declaration of Conformity</b> .....	<b>28</b>

# 1 Safety

- Read and follow the instructions of this manual.
- Inform yourself regarding hazards, which can be caused by the product or arise in your system.
- Comply with all safety instructions and regulations for accident prevention.
- Check regularly that all safety requirements are being complied with.
- Take account of the ambient conditions when installing your gauge. The protection class is IP 40 (the unit is protected against penetration of foreign bodies) or IP 54 when using suitable electrical connectors.
- Adhere to the applicable regulations and take the necessary precautions for the process media used.
- Consider possible reactions between materials and process media.
- Consider possible reactions of the process media due to the heat generated by the product.
- Before you start working, find out whether any of the vacuum components are contaminated.
- Adhere to the relevant regulations and take the necessary precautions when handling contaminated parts.
- Communicate the safety instructions to other users.

This instruction manual highlights potential hazards where appropriate. Safety notes and warning messages are tagged with one of the keywords DANGER, WARNING, CAUTION, NOTICE and NOTE as follows:

## DANGER

... indicates an imminent dangerous situation that will result in death or serious injuries if not prevented.

## WARNING

... indicates a potentially dangerous situation that could result in death or serious injuries.

## CAUTION

... indicates a potentially dangerous situation that could result in minor injuries.

## NOTICE

... indicates a potentially dangerous situation that could result in damage to property.

## NOTE

... indicates helpful tips and recommendations, as well as information for efficient and trouble-free operation.

## 2 Product Description

The digital transmitter DPH 400 consists of combined Pirani and hot cathode after Bayard-Alpert sensors whose measurement principles are based respectively on the thermal conductivity of gases and the ionization probability.

Those sensors provide indirect pressure measurements which are dependent on the gas nature.

The DPH 400 D is the same gauge but equipped with a LCD display.

### 2.1 Interface Illustration

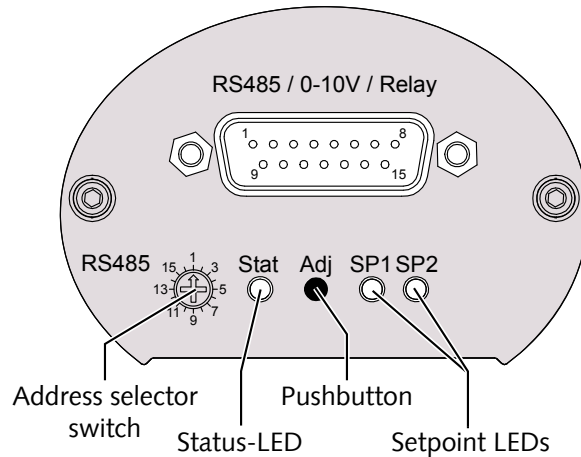

### 2.2 Product Identification

The product model can be found on the product's nameplate. Technical modifications are reserved without prior notification.

### 2.3 Delivery Content

Included in the delivery consignment are:

- Digital transmitter DPH 400
- Protective cover
- Instruction manual

Available accessories, consult the chapter Spare Parts and Accessories [► 25].

### 2.4 Proper Use

The DPH 400 serves exclusively to measure total pressure in a range of:

- 1000 ...  $5 \times 10^{-10}$  mbar.

### 2.5 Improper Use

The use for purposes not mentioned above is regarded as improper, especially:

- Connection to pumps or units which are not suitable for this purpose according to their operating instructions.
- Connection to units which have exposed voltage-carrying parts.
- Operation of the devices in areas with ionizing radiation.

No liability or warranty will be accepted for claims arising from improper use.

## 3 Transport and Storage

- Check the device for transport damage.

### NOTICE

Devices without external protection.

#### **Risk of damage to the device!**

- The device must not come into contact with electrostatically chargeable materials and must not be moved within electrical or high magnetic fields.

If a storage is planned:

- Seal the vacuum flange with the protective cover.
- Comply with the storage temperatures, see technical data.
- In rooms with moist or aggressive atmospheres, the device must be airproof shrink-wrapped in a plastic bag together with a bag a desiccant.

## 4 Installation

### CAUTION

Unauthorized modifications.

#### **Risk to injury!**

- Modifications or conversions of the gauge are not allowed.

### 4.1 Installation Conditions

- Make sure that the environment of the device is not potentially explosive.
- Make sure that the ambient conditions comply with the Technical Data [► 26].

### 4.2 Vacuum Connection

#### CAUTION

Unintended opening of clamp with an overpressure in the vacuum system over 1000 mbar.

#### **Risk to injury!**

#### **Damage to your health!**

- Parts may fly around.
- Unsecured hose connections can release process media.

#### CAUTION

Overpressure in the vacuum system over 1500 mbar

#### **Damage to your health!**

The elastomer washers cannot withstand the pressure and can release process media.

- Use sealing rings with an outer centering ring.

**! NOTICE**

Dirt and damage at the vacuum flange.

**Impair the function of the gauge!**

- Make sure that the flange is clean, dry and free of grease.
- When handling the instrument, make sure that the flange is protected against dirt and damage.

- 
- Remove the protective cover (is required again during maintenance work!).
  - Connect the flange to the system.

Connection size:

- ISO KF 25 or ISO KF 40

- Make sure that the sensor flange is connected to the ground.

**Mounting position:**

The installation position can be freely selected. The preferred position is a horizontal to vertical position so that condensate and particles do not penetrate the measurement chamber.

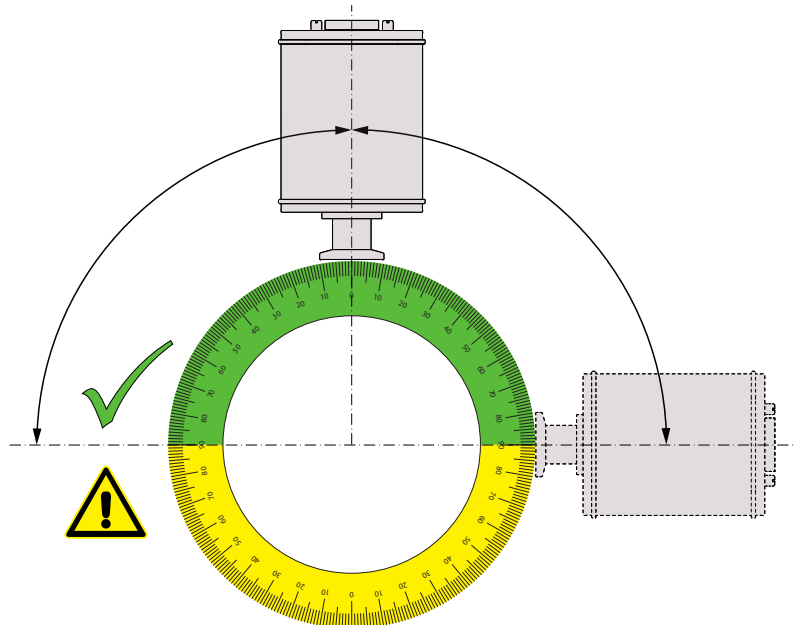

## 4.3 Electrical Connection

### ! NOTICE

Establish a connection using a live cable.

#### Risk of damage to the device!

- Only connect cables when de-energised.

### 4.3.1 Connecting to the Active Sensor Controller

For operation of the gauge with controller, a suitable measurement connection cable must be used (see accessories).

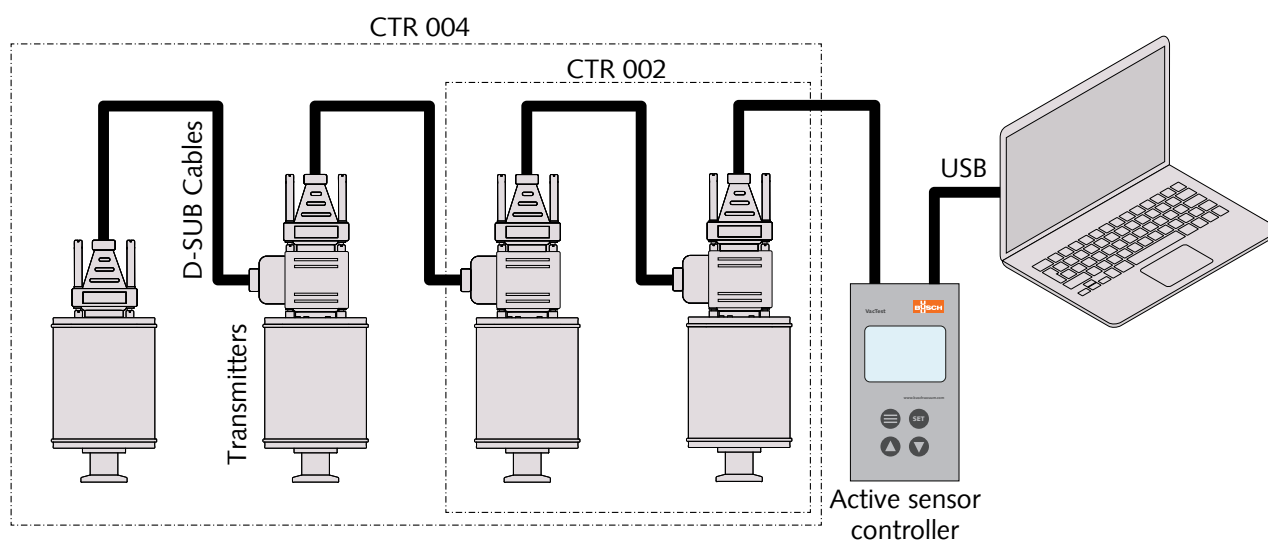

With the controller CTR 002: up to 2 gauges can be connected.

With the controller CTR 004: up to 4 gauges can be connected.

- Set the relevant address at the address selector switch, see Setting RS485 Address [▶ 17].
- Connect the D-Sub connector to the gauge and secure it with the screws.
- Connect the controller and secure the D-Sub connector with the screws.
- Switch on the controller.

### 4.3.2 Connecting to the USB/RS485 Converter

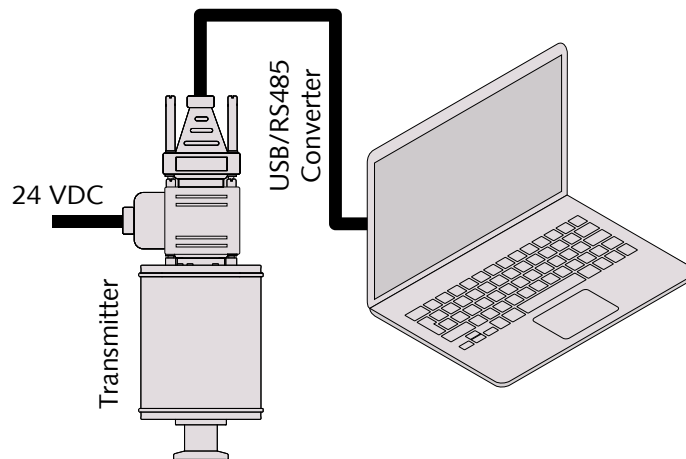

- Set the relevant address at the address selector switch, see Setting RS485 Address [▶ 17].
- Connect the gauge to the power supply cable.
- Connect the USB/RS485 converter and secure the D-Sub connector with the screws.
- Connect the power supply cable to the mains.



### 4.3.3 I/O and Communication Port Schematic

The electrical connection is to be made by means of suitable cables considering EMI demands and according to the pin description shown below:

**Connector:** D-Sub15, 15-pin, male

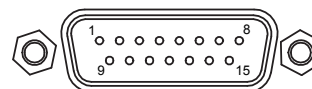

Pin no.	Description	Pin no.	Description
1	Identification	2	Signal Output 0 ... 10 VDC
3	AGND	4	Voltage Supply 24 VDC
5	Supply GND	6	Relay 1, NO (normally open)
7	Relay 1, Common	8	Relay 1, NC (normally closed)
9	Degas, extern	10	RS485, D+
11	RS485, D-	12	Ground
13	Relay 2, NO (normally open)	14	Relay 2, Common
15	Relay 2, NC (normally closed)		

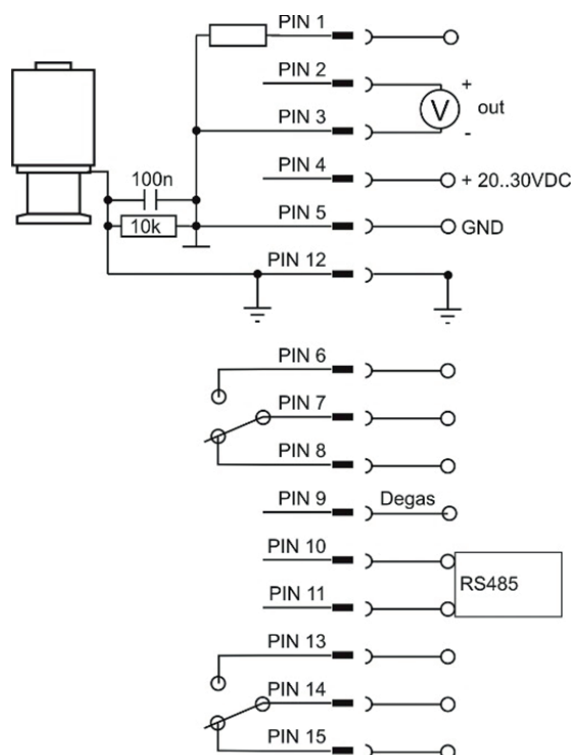

#### NOTE

We recommend to have "Ground" (Pin 12) and supply common (Pin 5) grounded.

#### NOTICE

Incorrect supply voltage.

**Risk of damage to the device!**

- Make sure to supply a correct and admissible voltage.

## 4.4 Change Display Unit and Orientation (Display version only)

In order to change the display unit (mbar, Torr, hPa):

- Hold the "Adj" pushbutton pressed while connecting power supply until the display shows "Unit".
- Select the desired unit by pressing the "Adj" pushbutton.

Display unit and orientation can be changed via VacTest explorer or by software command, see chapter Commands Overview [► 18].

# 5 Operation

### NOTICE

Aggressive media such as fluorides, halogenides, carbon, oxygen plasma and all other corrosive media.

#### **Reduce sensor life-time!**

- Furthermore, dust, oil or condensing vapours will affect sensor performance and may cause malfunction.

### NOTICE

Hydrocarbons contamination.

#### **Wear of the hot cathode sensor!**

- Protect the gauge from oil backstreaming of oil-lubricated vacuum pump.

## 5.1 Before Operation

### **Warm-Up Time**

The signal output of the gauge is available approx. 2 seconds after the unit is switched on.

To take advantage of the maximum accuracy of the unit it is advisable to wait 5 ... 10 minutes for stabilization before measurement.









### **Dependence On Gas Type**

The measured pressure will depend on composition and type of gas. The gauge is factory calibrated for N<sub>2</sub> and dry air.

To adjust to other gases, a suitable correction factor for Pirani and Bayard-Alpert sensors can be set in the gauge for the pressure range below 0.1 mbar, see Gas Correction Factor [► 27].

## 5.2 Operating the Gauge

The gauge is equipped with a status LED (see Interface Illustration [▶ 4]) signalizes the following operational states:

-  Normal operation / hot cathode on (green LED continuously on)
-  Normal operation / hot cathode off (green LED flashing slowly)
-  Initializing input (green LED flashing quickly)
-  Error (red LED continuously on)
-  Degas on (red LED flashing slowly)
-  Initializing degas (red LED flashing quickly)
-  Warning: hot cathode filament 1 defective (orange LED continuously on)
-  Ready for adjustment (orange LED flashing slowly)
-  Initializing adjustment (orange LED flashing quickly)

The setpoint LEDs are on when the related relay is activated.

For gauges with LCD display:

Operation error or malfunction the display is illuminated by a red background color.

### 5.2.1 Operating Flowchart

By means of the "Adj" pushbutton of the gauge "degas" and "adjustment" functions can be started.

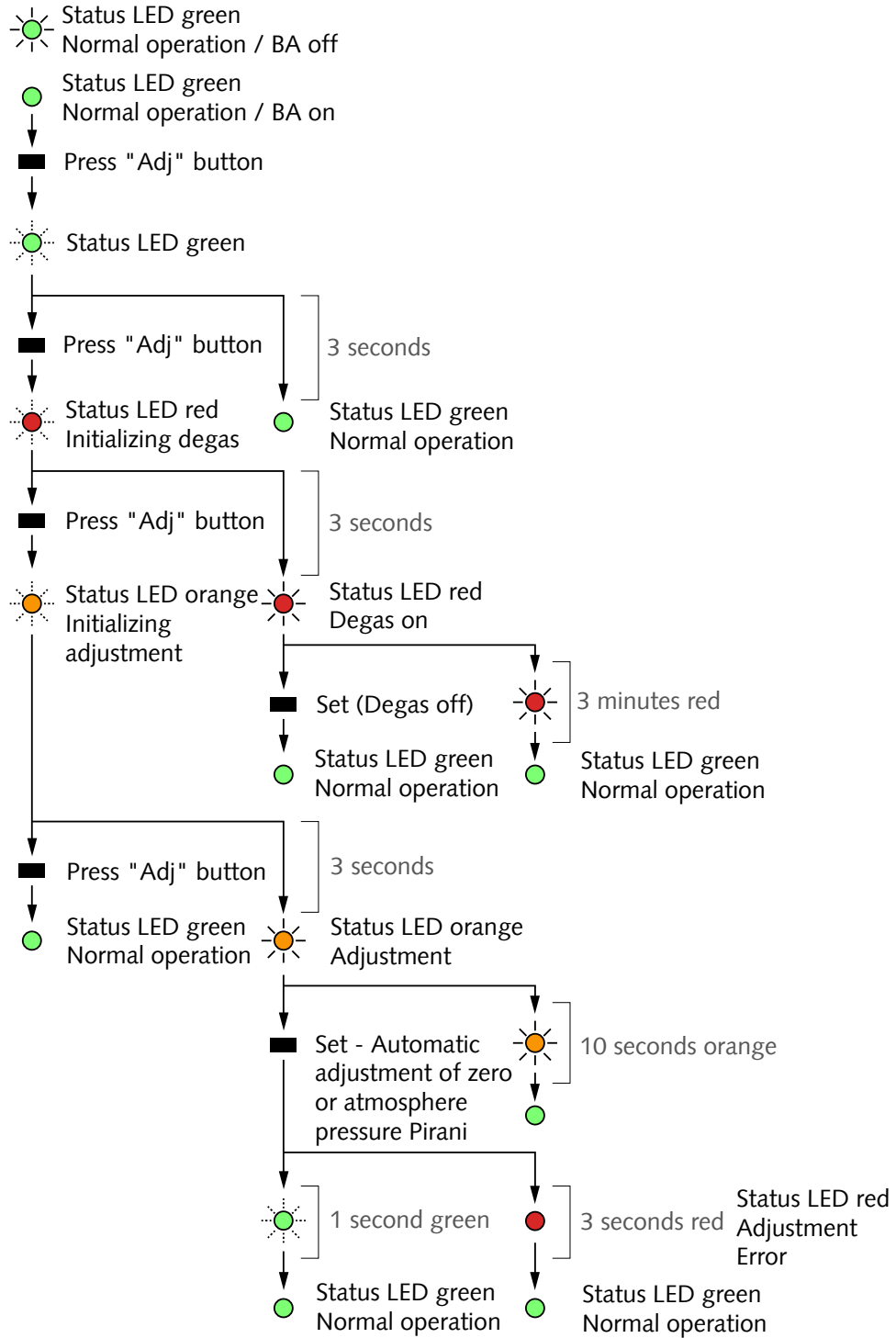

## 5.3 Setpoints

The gauge features 2 independent, potential-free relay contacts that can be configured via RS485 and VacTest explorer.

The 2 relays are controlled by the two setpoints SP1 and SP2.

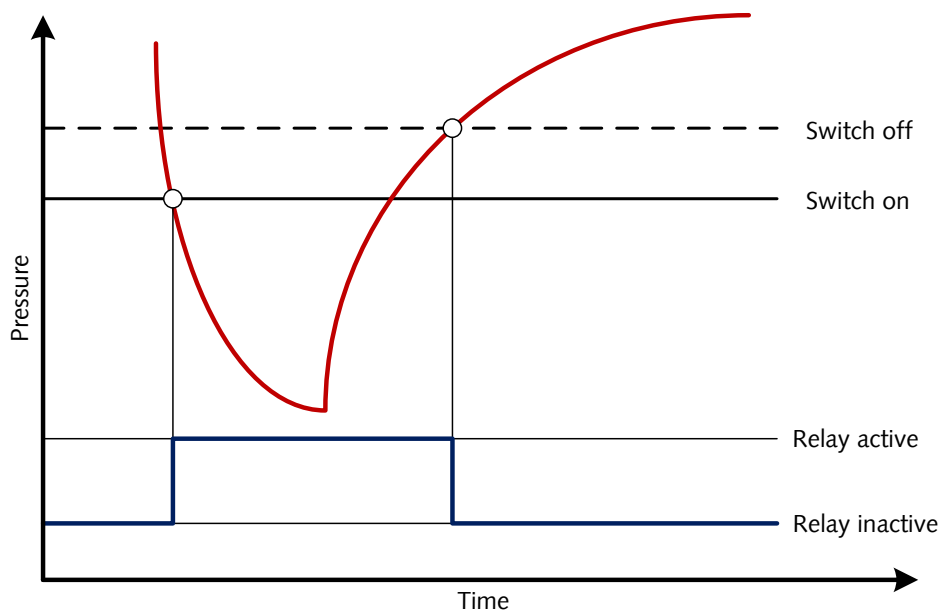

## 5.4 Degas

Deposition or adsorbed gas molecules on the electrodes of the hot cathode sensor may lead to increased degassing in ultra-high vacuum or even cause instabilities of the measurement signal.

In this case it is appropriate to clean the sensor anode from adsorbed gas molecules by degassing at a pressure below  $2.0 \times 10^{-6}$  mbar. The degassing is done by ohmic heating of the anode to temperatures around 800 °C.

### NOTE

The degas procedure will stop automatically after approx. 3 minutes, but can be cancelled any time.

While the sensor is degassing the red status LED is flashing slowly in red color.

### 5.4.1 Degas Control by Pushbutton

The degas function can be activated directly at the gauge by means of the “Adj” pushbutton, see Operating Flowchart [► 12].

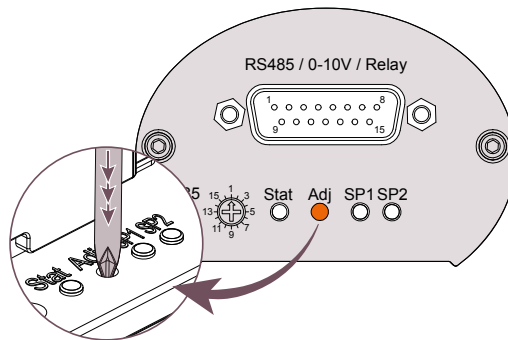

- Remove the rubber cap above the “Adj” pushbutton.
- Press the button several times by means of a small screwdriver or similar tool until the status LED starts quickly flashing in red color.

After 3 seconds the degas process starts.

- Reinsert the rubber cap.

### 5.4.2 Degas Control by External Voltage Signal

Degas can be started simply by connecting Pin 9 (see chapter I/O and Communication Port Schematic [► 9]) to a defined voltage level for a short moment (min. 20 ms). Depending on the setting of software parameter “Degas Logic” the degas procedure starts, as soon as pin 9 is

- connected to GND for a short moment (parameter set to 0, active low, default setting) or
- connected to 3 ... 24 VDC for a short moment (parameter set to 1, active high).

The degas process can be cancelled any time by again connecting Pin 9 in the above mentioned manner.

### 5.4.3 Degas Control via Software Command

Degas can be controlled either via VacTest explorer software or in accordance with the communication instructions, see chapter Commands Overview [► 18].

### 5.4.4 Degas Control via Controller

See instruction manual of the controller.

## 5.5 Bake-out

### NOTICE

Excessive bake-out temperature.

#### **Risk of damage to the electronics!**

- Baking temperatures up to 180 °C, always switch off the power supply.
- Baking temperatures higher than 180 °C may damage the sensor head and electronics.
- The vacuum flange and the sensor must not be thermally isolated. During baking it needs to be cooled by natural convection of ambient air.

## 5.6 Readjustment

The gauge is factory calibrated in upright position. Other orientations, different climatic conditions, extreme temperature changes, ageing or contamination may necessitate re-adjustment.

### NOTE

Conduct adjustment at the same ambient temperature at which the device is typically operated.

### NOTE

For zero adjustment actual pressure should be less than  $5 \times 10^{-5}$  mbar.

### NOTE

To achieve optimum results of the adjustment we recommend to consider a warm-up of at least 10 minutes at the appropriate calibration pressure before any adjustment.

### 5.6.1 Readjustment by Pushbutton

Readjustment on atmosphere or zero pressure can be done by means of the “Adj” pushbutton of the gauge. The gauge will notice automatically which adjustment point is relevant.

See Operating Flowchart [▶ 12].

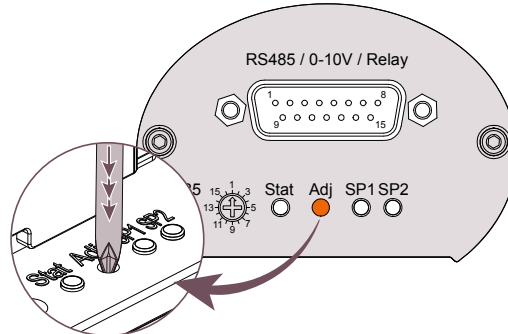

- Remove the rubber cap above the “Adj” pushbutton.
- Press the button several times by means of a small screwdriver or similar tool until the status LED starts quickly flashing in orange color.

After further 3 seconds, a slowly flashing status LED signalizes that the gauge now can be readjusted

- Push the button once again
- Reinsert the rubber cap.

### 5.6.2 Readjustment via Software Command

Readjustment can be controlled either via VacTest explorer software or in accordance with the communication instructions, see chapter Readjustment [▶ 20].

### 5.6.3 Readjustment via Controller

See instruction manual of the controller.



## 6 Communication

### NOTE

The Busch communication protocol is available separately on request.

**Ask your Busch representative to get the document.**

### 6.1 Setting RS485 Address

The transmitter is equipped with a serial RS485 interface.

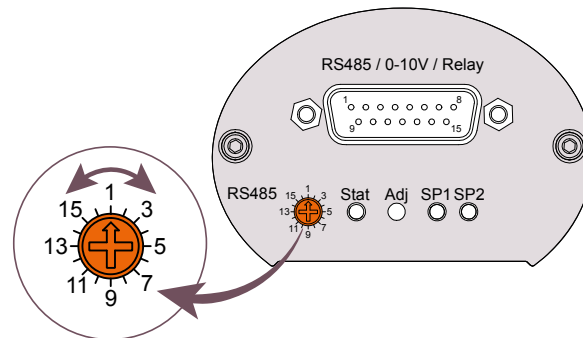

The communication is effected via serial interface RS485:

- Remove the rubber cap over the address selector switch.
- Set the address selector switch to a value between 1 and 16 using a small screwdriver.
- Reinsert the rubber cap.

### NOTE

The analog output signal 0-10V is simultaneously available with RS485 !

## 6.2 Commands Overview

### Main commands:

Code	Description	DTP 400	DPP 400	DPH 400	DPC 400	DCC 400
TD	Displays the device type.	x	x	x	x	x
PN	Displays the product name.	x	x	x	x	x
SD	Displays the device serial number .	x	x	x	x	x
SH	Displays the sensor head serial number.	x	x	x	x	x
VD	Displays the device's hardware version.	x	x	x	x	x
VF	Displays the device's firmware version.	x	x	x	x	x
VB	Displays the device's bootloader version.	x	x	x	x	x
BR	Set the baud rate for data transmission Value range: 9600, 14400, 19200, 28800, 38400, 57600, 115200 Bd.	x	x	x	x	x
RD	Display and set the time delay between receiving a telegram and sending the answer. Value range: 1 ... 99999 µs (default 5500 µs).	x	x	x	x	x
DR	Make a device reset.	x	x	x	x	x
MR	Displays the measurement range of the gauge.	x	x	x	x	x
MV	Displays the current pressure measurement.	x	x	x	x	x
M1	Displays the current pressure of the Pirani sensor.	x	x	x	x	
M2	Displays the current pressure of the Piezo sensor.		x			
M3 <sup>(2)</sup>	Displays the current pressure of the hot cathode sensor.			x		
M4 <sup>(2)</sup>	Displays the current pressure of the cold cathode sensor.				x	
DU <sup>(1)</sup>	Display and set the pressure unit used for the LCD display of the gauge. Value range: mbar (default), Torr, hPa.	x	x	x	x	x
DO <sup>(1)</sup>	Display and set the display orientation, i.e. the display can be rotated by 180°. Value range: 0 (default), 1 (rotated 180°).	x	x	x	x	x
R1	Display and set the relay mode: see chapter Setpoints [► 20] for more information.	x	x	x	x	x
R2						
AH	Adjustment of the Pirani sensor at atmospheric pressure. See chapter Readjustment [► 20] for more information.	x	x	x	x	
AL	Adjustment of the Pirani sensor at zero pressure. See chapter Readjustment [► 20] for more information.	x	x	x	x	

<sup>(1)</sup> Valid only for transmitters with LCD display.

<sup>(2)</sup> Not available when cathode is switched off.

**Gauge parameters:**

Code	Description	DTP 400	DPP 400	DPH 400	DPC 400	DCC 400
DG	Control the degas process and display the status. See chapter Degas [▶ 21] for more information.			x		
DL	DPH400 ▶ Configure the degas logic. See chapter Degas [▶ 21] for more information. DCC400 ▶ Configure the cathode control logic. See chapter Ionization Sensor [▶ 22] for more information.			x		x
CM	Configure the cathode control mode. See chapter Ionization Sensor [▶ 22] for more information.					x
ST	Configure the transition between the sensors. See chapter Sensor Transition [▶ 21] for more information.		x	x	x	
CC	Configure the control of the ionization sensor. See chapter Ionization Sensor [▶ 22] for more information.			x	x	x
FC	Configure the use of the hot cathode filaments. See chapter Ionization Sensor [▶ 22] for more information.			x		
FN	Displays which hot cathode filament is currently activated.			x		
FS	Displays the status of the hot cathode filaments. See chapter Ionization Sensor [▶ 22] for more information.			x		
C1	Display and set the gas correction factor for the Pirani sensor.	x	x	x	x	
C3	Display and set the gas correction factor for the hot cathode sensor.			x		
C4	Display and set the gas correction factor for the cold cathode sensor.				x	x
OC	Scale the analog output characteristic of the gauge: consult the Busch communication protocol.	x	x	x	x	x

## 6.2.1 Setpoints

The gauge provides 2 independent, potential-free relay setpoints. These are available as change-over switches at the connector according to the pin assignment described in chapter I/O and Communication Port Schematic [► 9].

### Relay R1, R2:

The relays can be independently configured for various switching modes. The Parameter is used to query and set these switching modes.

#### Settings:

Settings	Meaning
T[p <sub>1</sub> ] F[p <sub>2</sub> ]	2 pressure thresholds T[p <sub>1</sub> ] (true) und F[p <sub>2</sub> ] (false) are transmitted. T[p <sub>1</sub> ] < F[p <sub>2</sub> ] Relay closes below p <sub>1</sub> and opens above p <sub>2</sub> T[p <sub>1</sub> ] > F[p <sub>2</sub> ] Relay opens below p <sub>2</sub> and closes above p <sub>1</sub>
E	Relay closes in case of a device error.
!E	Relay opens in case of a device error.
U	Relay closes in case of pressure under-range.
!U	Relay opens in case of pressure under-range.
O	Relay closes in case of pressure over-range.
!O	Relay opens in case of pressure over-range.
C	Relay closes when cathode is switched on.
!C	Relay opens when cathode is switched on.
T0	Open relay by software command (off).
T1	Close relay by software command (on).

### NOTICE

Setting T[p<sub>1</sub>] = F[p<sub>2</sub>] is forbidden!

#### Risk of damage to the relay!

- A gap between the thresholds being too small will result in flickering of the relay

## 6.2.2 Readjustment

### Adjust High AH:

Adjustment of the Pirani sensor at atmosphere pressure

### Adjust Low AL:

Adjustment of the Pirani sensor at zero pressure. For this purpose, actual pressure must be less than  $5 \times 10^{-5}$  mbar.

## 6.2.3 Degas

### Degas (DG):

The parameter is used to control the degas procedure and query the status.

Settings	Meaning
0	Degas off
1	Degas on

### Degas Logic (DL):

Degas can be started by connecting Pin 9 (see chapter I/O and Communication Port Schematic [▶ 9]) to a defined voltage level for a short moment (min. 20 ms). With parameter Degas Logic (DL) you can configure, whether a 3 ... 24 VDC signal or GND shall be used:

Settings	Meaning
0 (Default)	GND, active low
1	3 ... 24 VDC, active high

## 6.2.4 Sensor Transition

### Sensor Transition (ST):

By default the gauge performs a continuous transition between the two sensors range whereupon an assimilation of the sensor signals is carried out.

In order to adapt the performance of the gauge to the requirements of the vacuum process the following options can be configured via RS485 by means of parameter "Sensor Transition" (ST):

Settings	Meaning
0	No transition, but direct switch-over between the sensors.
1 (Default)	Continuous transition (low).
2	Continuous transition (high).
D[p]:	No transition, but direct switch-over between the sensors.at pressure "p"
F[p <sub>1</sub> ] T[p <sub>2</sub> ]	Continuous transition in the range p <sub>1</sub> ... p <sub>2</sub>

Settings	Transition range / DHP 400
0	4 x 10 <sup>-4</sup> mbar Hot cathode "ON" at 4 x 10 <sup>-4</sup> mbar Hot cathode "OFF" at 6 x 10 <sup>-4</sup> mbar
1 (Default)	1 ... 2 x 10 <sup>-3</sup> mbar Hot cathode "ON" at 3 x 10 <sup>-3</sup> mbar Hot cathode "OFF" at 4 x 10 <sup>-3</sup> mbar
2	2 ... 5 x 10 <sup>-3</sup> mbar Hot cathode "ON" at 8 x 10 <sup>-3</sup> mbar Hot cathode "OFF" at 9 x 10 <sup>-3</sup> mbar
Value range p, p <sub>1</sub> , p <sub>2</sub>	4 x 10 <sup>-4</sup> ... 1 x 10 <sup>-2</sup> mbar

## 6.2.5 Ionization Sensor

### Cathode Control (CC):

It is possible to disable the ionization sensor by software command "Cathode Control" (CC) via RS485 interface:

Settings	Meaning
0	disabled ► ionization sensor remains switched off.
1 (Default)	enabled ► automatic ionization sensor control.

When the ionization sensor is disabled the gauge behaves like a Pirani transmitter with range 1000 -  $1 \times 10^{-4}$  mbar.

Below  $1 \times 10^{-4}$  mbar the serial interface sends a "ur" signal for under-range, the analog output remains at a voltage corresponding to  $1 \times 10^{-4}$  mbar.

### NOTE

Parameter "Cathode Control" is only temporarily saved in the gauge memory. After mains supply is switched off or disconnected the parameter will be reset to "1" and the ionization sensor enabled!

### Filament Control (FC):

The Bayard-Alpert hot cathode sensor of the gauge is equipped with two filaments. This parameter defines in which manner these filaments will be used:

Settings	Meaning
0 (Default)	Filament 1 active, in case of a defect the sensor will switch to filament 2.
1	Only filament 1 will be used.
2	Only filament 2 will be used.
3	Filament 1 and 2 will be used alternately. I.e. when the hot cathode sensor is switched off the other filament will be activated at restart of the sensor.

### Filament Status (FS):

This parameter is used to check the failure status of the Bayard-Alpert hot cathode sensor:

Settings	Meaning
0	No error, Filament 1 and 2 ok
1	Filament 1 defective
2	Filament 2 defective
3	Filament 1 and 2 defective

### NOTE

As soon as one filament is reported to be defective it is strongly recommended to replace the sensor head as soon as possible!

## 6.3 VacTest Explorer Software

VacTest explorer software has been especially developed for use with Busch vacuum gauges and is available for Windows and Android operating systems. VacTest explorer features plotting and saving of measurement data as well as a comfortable way of configuring all device parameters.

Download VacTest explorer software on the Busch website [www.buschvacuum.com](http://www.buschvacuum.com).

Features example:

- Plot, analyze and save measurement curves.
- Compare multiple plots.
- Export measurement data for MS Excel.
- Automatic calculation of leak rates by rate-of-rise measurements.
- Easy configuration of all device parameters.
- Scaling wizard with graphic support for adjusting the voltage output characteristic.
- The voltage output curve can be modified through the VacTest explorer software and can directly replace gauges of other brands.

## 7 Maintenance and Service



### **WARNING**

Units contaminated with hazardous material.

**Risk of poisoning!**

**Risk of infection!**

If the unit is contaminated with hazardous material:

- Wear appropriate personal protective equipment.

### **NOTICE**

The unit is not prepared for customer repair.

**Risk of damage to the unit!**

- Defective sensor heads can be exchanged on-site by calibrated replacement sensors.

The device requires no maintenance. External dirt and soiling can be removed by a damp cloth.

Should a defect or damage occur on the device, please send the unit to us for repair and fulfil the declaration of decontamination downloadable from [www.buschvacuum.com](http://www.buschvacuum.com).

### **NOTE**

Malfunction of the unit, which is caused by contamination or wear and tear is not covered by warranty.

## 7.1 Replacing the Sensor Head

### Disassembly:

- Vent the vacuum system to atmospheric pressure and allow to cool.
- Switch off the power supply on the controller or disconnect the gauge from the mains.
- Disconnect the gauge from the flange.
- Unscrew the knurled nuts paying attention to the sealing washers.
- Remove carefully the housing.

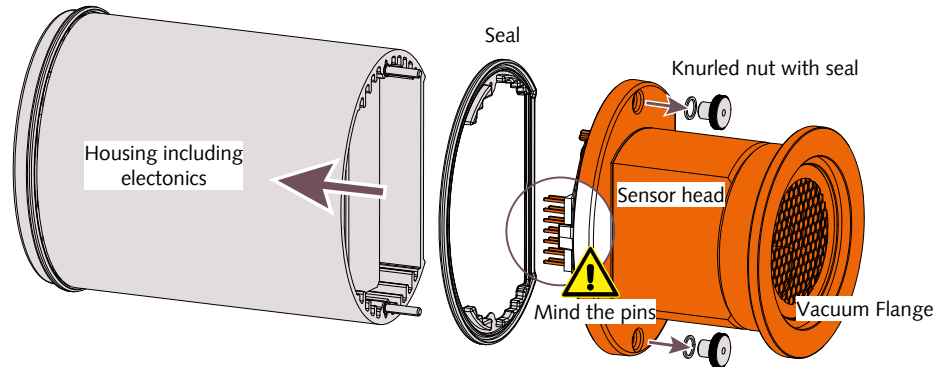

### Assembly:

- Assemble carefully the housing and the sensor head (pay attention to pins and seal positions).
- Screw in the knurled nuts with their respective seal.
- Install the gauge.

## 8 Troubleshooting

Problem	Possible Cause	Remedy
High measurement error.	Contamination, ageing, extreme temperature, maladjustment.	• Readjustment, replace sensor or send unit for repair.
Pirani zero adjustment not possible.	Measurement error exceeds possible range of readjustment.	• Replace sensor or send unit for repair.
0.5V < output signal < 1.0V "UR" via RS485.	Pressure under range.	• Pressure < 5 x 10 <sup>-10</sup> mbar.
Output signal < 0.5V / "ERROR1" via RS485 Status LED continuously red.	Defective electronics or sensor.	• Send unit for repair or replace sensor.
Status LED continuously orange.	Hot cathode filament 1 defective.	• If appropriate replace sensor.
Access code "7" via RS485.	Error message / warning.	• Contact Busch for communication protocol.



## 9 Spare Parts and Accessories

Spare part	Description	Part no.
Spare sensor	Intended for: - DPH 400 (DN 25 ISO-KF flange) - DPH 400 D (DN 25 ISO-KF flange)	0680 204 600
Spare sensor	Intended for: - DPH 400 (DN 40 ISO-KF flange) - DPH 400 D (DN 40 ISO-KF flange)	0680 204 601
Controller	Description	Part no.
Active Sensor Controller	CTR 002, 2 channels	0656 202 928
Active Sensor Controller	CTR 004, 4 channels	0656 202 929
Accessory	Description	Part no.
Connecting cable	2x D-Sub 15 poles – 2 meters	0671 204 577
Connecting cable	2x D-Sub 15 poles – 6 meters	0671 204 578
Connecting cable	2x D-Sub 15 poles – 10 meters	0671 204 580
Connecting cable	2x D-Sub 15 poles – 20 meters	0671 204 581
Bluetooth module	RS485 Interface converter to Bluetooth	0680 204 592
Connecting cable	RS485 Interface converter to USB	0671 204 593
Power supply	100-240 VAC / 50-60Hz, 300 mA - with EURO/ US/UK/AUS plugs	0671 204 594
Software	VacTest explorer - Pro version (1 license)	0870 203 191

This is only part of the available accessories, check on Busch's website or contact your Busch representative for more information.

# 10 Technical Data

		VacTest DPH 400
Measurement principle		Pirani / Bayard-Alpert
Materials exposed to vacuum		Stainless steel 1.4307, Ni, W, Pt, yttrium coated iridium, glass
Number of filaments	Pirani	1
	Bayard-Alpert	2
Filament material	Pirani	Tungsten
	Bayard-Alpert	Yttrium coated iridium
Measuring range	mbar	1000 ... $5 \times 10^{-10}$
	torr	750 ... $3.75 \times 10^{-10}$
Overpressure limit	bar abs.	4
Measurement uncertainty	% of reading	1000 ... 10 mbar: $\pm 30$ %
		10 ... $1 \times 10^{-8}$ mbar: $\pm 10$ %
Repeatability of measurement	% of reading	10 ... $1 \times 10^{-2}$ mbar: $\pm 2$ %
		$1 \times 10^{-2}$ ... $1 \times 10^{-8}$ mbar: $\pm 5$ %
Leakage rate	mbar l/s	$< 5 \times 10^{-10}$
Reaction time	ms	< 50
Serial Interface		RS485
Electrical Connection		D-Sub, 15-pin, male
Supply voltage	V	20 ... 30
Max. power consumption	W	normal operation 9
	W	degas 1
	W	relays/display 0.8
Output signal		0 ... 10 V, RS485
Output function	V	$0.7 \times \log(p_{\text{mbar}}) + 7.8$
Under-range voltage	V	0.9
Error	V	0.4
Setpoint relay		2 dry contacts
Relay contact rating		2A, 50 VAC / 2 A, 30 VDC, max. 60 VA
Operating Temperature	°C	+5 ... +60
Storage Temperature	°C	-40 ... +65
Max. bake-out temperature at the flange	°C	180
Relative Humidity:		max. 80% up to 30°C, max. 50% at 40°C, not condensing
Ambient pressure:	hPa (mbar)	860 ... 1060
Protection Class		IP40 (IP54 with appropriate D-Sub connector)
Weight	g	475

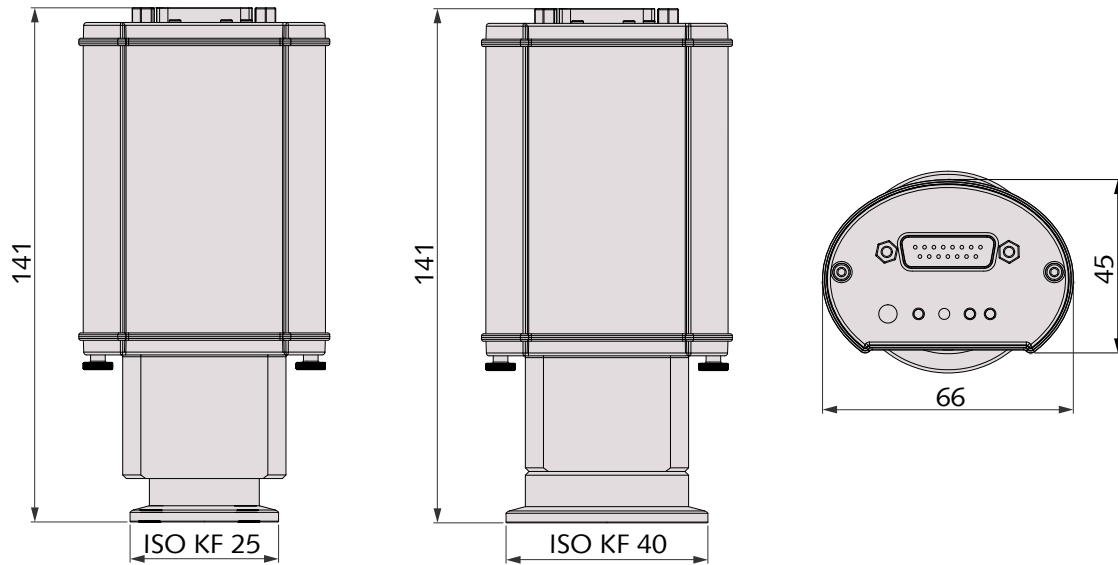

## 10.1 Gas Correction Factor

Value range ▶ 0.20 ... 8.0

### Correction factor for Pirani sensor:

Ar ▶ 1.6	CO <sub>2</sub> ▶ 0.89	He ▶ 1.0	Ne ▶ 1.4
CO ▶ 1.0	H <sub>2</sub> ▶ 0.57	N <sub>2</sub> ▶ 1.0	Kr ▶ 2.4

### Correction factor for hot cathode sensor:

Ar ▶ 0.80	H <sub>2</sub> ▶ 2.4	N <sub>2</sub> ▶ 1.0	Kr ▶ 0.6
CO <sub>2</sub> ▶ 0.74	He ▶ 5.9	Ne ▶ 3.5	Xe ▶ 0.41

# 11 EU Declaration of Conformity

This Declaration of Conformity and the CE-mark affixed to the nameplate are valid for the gauge within the Busch scope of delivery. This Declaration of Conformity is issued under the sole responsibility of the manufacturer.

The manufacturer

**Busch Produktions GmbH**  
**Schauinslandstr. 1**  
**DE-79689 Maulburg**

declare that the gauge VacTest DPH 400

has been manufactured in accordance with the European Directives:

- ‘Electromagnetic Compatibility (EMS) ’ 2014/30/EU
- ‘RoHS’ 2011/65/EU, restriction of the use of certain hazardous substances in electrical and electronic equipment

and following the standards.

Standard	Title of the Standard
EN 61326-1:2013 Group 1 / Class B	Electrical equipment for measurement, control and laboratory use. EMC requirements. General requirements
EN 50581:2012	Technical documentation for the assessment of electrical and electronic products with respect to the restriction of hazardous substances

Person authorised to compile the technical file:

Gerd Rohweder  
Busch Dienste GmbH  
Schauinslandstr. 1  
DE-79689 Maulburg

Maulburg, 24.08.2017



**Martin Gutmann, General director**

A large, empty rectangular box with a thin grey border, occupying most of the page. It is intended for writing a note.

Note

A large, empty rectangular box with a thin gray border, occupying most of the page below the 'Note' header. It is intended for the user to write their notes.

A large, empty rectangular box with a thin gray border, occupying most of the page. It is intended for writing a note.

# Busch

## Vacuum Solutions

We shape vacuum for you.

### Argentina

info@busch.com.ar

### Australia

sales@busch.com.au

### Austria

busch@busch.at

### Bangladesh

sales@busch.com.bd

### Belgium

info@busch.be

### Brazil

vendas@buschdobrasil.com.br

### Canada

info@busch.ca

### Chile

info@busch.cl

### China

info@busch-china.com

### Colombia

info@buschvacuum.co

### Czech Republic

info@buschvacuum.cz

### Denmark

info@busch.dk

### Finland

info@busch.fi

### France

busch@busch.fr

### Germany

info@busch.de

### Hungary

busch@buschvacuum.hu

### India

sales@buschindia.com

### Ireland

sales@busch.ie

### Israel

service\_sales@busch.co.il

### Italy

info@busch.it

### Japan

info@busch.co.jp

### Korea

busch@busch.co.kr

### Malaysia

busch@busch.com.my

### Mexico

info@busch.com.mx

### Netherlands

info@busch.nl

### New Zealand

sales@busch.co.nz

### Norway

post@busch.no

### Peru

info@busch.com.pe

### Poland

busch@busch.com.pl

### Portugal

busch@busch.pt

### Romania

office@buschromania.ro

### Russia

info@busch.ru

### Singapore

sales@busch.com.sg

### South Africa

info@busch.co.za

### Spain

contacto@buschiberica.es

### Sweden

info@busch.se

### Switzerland

info@buschag.ch

### Taiwan

service@busch.com.tw

### Thailand

info@busch.co.th

### Turkey

vakutek@ttmail.com

### United Arab Emirates

sales@busch.ae

### United Kingdom

sales@busch.co.uk

### USA

info@buschusa.com