

DOLPHIN LT 0130-0220 A

Liquid ring vacuum pumps



VACUUM SOLUTIONS



Robust

Proven technology, durable two-stage construction, corrosion-free stainless steel impeller, direct flange-mounted motor, no base frame required, integrated flow channel

Reliable

Extremely high vapor and particle tolerance, optimized gas flow

Flexible

Choice of cast iron (EN-GJL-200) or 316 grade stainless steel material housings, ATEX-certified version available (Cat 1G (i) 2G (o) IIC T4), operating fluids other than water possible

Accessories

- Modular pumpsets, configured for once-through, partial or total recirculation of the operating fluid
- Liquid separator
- Cavitation protection
- Heat exchanger
- Gas ejector
- Wide selection of motors
- Non-return valves
- Vacuum relief valves
- Variable speed drive (only for LT 0170/0220 A)

DOLPHIN LT 0130-0220 A

Liquid ring vacuum pumps



VACUUM SOLUTIONS

Dimensional drawing

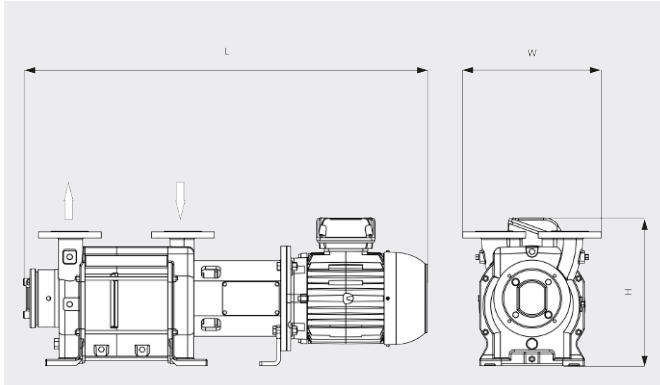

Pumping speed

Dry air at 20 °C. Operating fluid water 15 °C. Tolerance: - 10%, in accordance with HEI and Pneurop 6612

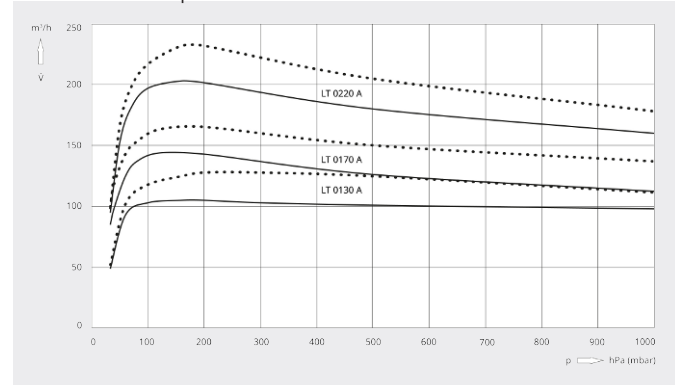

	DOLPHIN LT 0130 A	DOLPHIN LT 0170 A	DOLPHIN LT 0220 A
Nominal pumping speed	105 / 128 m³/h (50 / 60 Hz)	144 / 165 m³/h (50 / 60 Hz)	203 / 232 m³/h (50 / 60 Hz)
Ultimate pressure	33 hPa (mbar) (50 / 60 Hz)	33 hPa (mbar) (50 / 60 Hz)	33 hPa (mbar) (50 / 60 Hz)
Max. overpressure	1.5 bar(g) (50 / 60 Hz)	1.5 bar(g) (50 / 60 Hz)	1.2 bar(g) (50 / 60 Hz)
Nominal motor rating	3.0 / 4.0 kW (50 / 60 Hz)	4.0 / 5.5 kW (50 / 60 Hz)	5.5 / 7.5 kW (50 / 60 Hz)
Nominal motor speed	1450 / 1750 min ⁻¹ (50 / 60 Hz)	1450 / 1750 min ⁻¹ (50 / 60 Hz)	1450 / 1750 min ⁻¹ (50 / 60 Hz)
Noise level (ISO 2151)	70 / 71 dB(A) (50 / 60 Hz)	70 / 71 dB(A) (50 / 60 Hz)	70 / 71 dB(A) (50 / 60 Hz)
Weight approx.	139 kg	149 kg	188 kg
Dimensions (L x W x H)	906 x 330 x 329 mm	954 x 330 x 351 mm	1083 x 330 x 380 mm
Gas inlet / outlet	DN 40 PN 10 / DN 40 PN 10	DN 40 PN 10 / DN 40 PN 10	DN 40 PN 10 / DN 40 PN 10

DO YOU WANT TO KNOW MORE?

Get in touch with us directly!
info@busch.fi or +358 (0)9 774 60 60



CONTACT FORM



CALL NOW