

SAMOS SB 0710-1400 D0

Side channel blowers

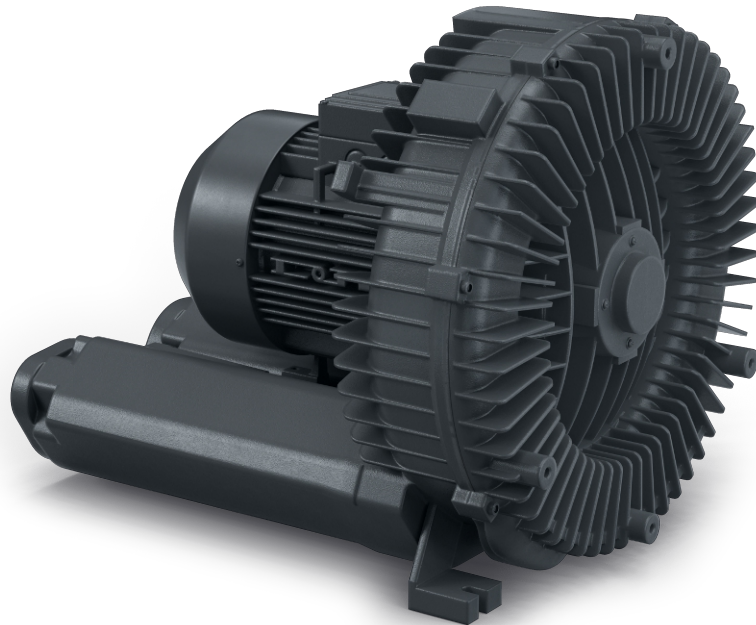

VACUUM SOLUTIONS



Reliable

Robust construction, effective air cooling, long lifetime, nearly maintenance-free, dry and contact-free operating principle

Flexible

Vacuum or overpressure operation, horizontal and vertical installation, various design options and ATEX-certified versions available

Quiet

Very low noise level, fully enclosed unit, internal silencers

Accessories

- Vacuum relief valves
- Pressure relief valves
- Additional silencers
- Thermal protection (bimetal switch or PTC-thermistor)

SAMOS SB 0710-1400 D0

Side channel blowers



VACUUM SOLUTIONS

Dimensional drawing

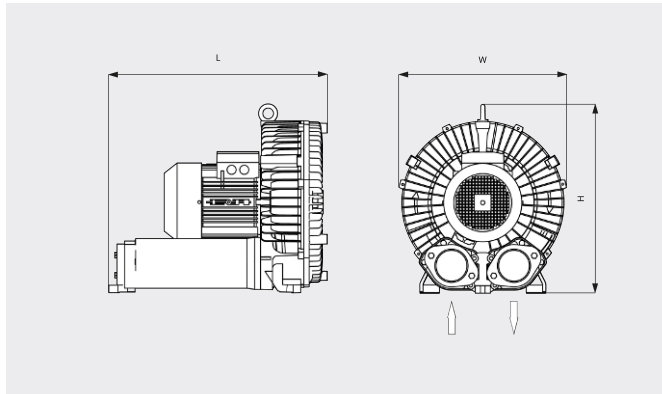

Pumping speed/Volume flow
Air at 20°C. Tolerance: ± 10%

— 50 Hz 60 Hz

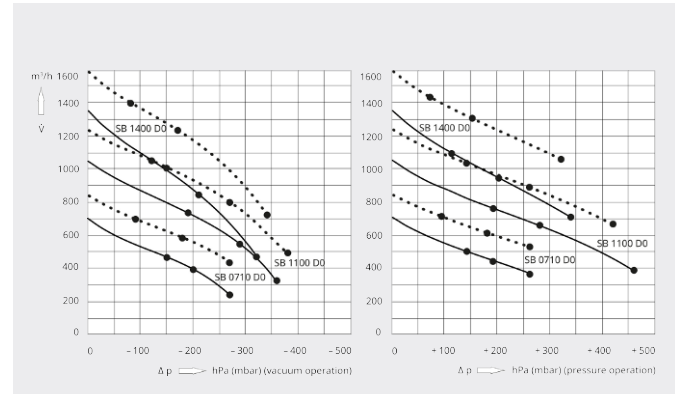

	SAMOS SB 0710 D0	SAMOS SB 0710 D0	SAMOS SB 0710 D0
Nominal pumping speed/volume flow	700 / 840 m ³ /h (50 / 60 Hz)	700 / 840 m ³ /h (50 / 60 Hz)	700 / 840 m ³ /h (50 / 60 Hz)
Max. differential pressure (vacuum version)	-150 / -90 hPa (mbar) (50 / 60 Hz)	-200 / -180 hPa (mbar) (50 / 60 Hz)	-270 hPa (mbar) (50 / 60 Hz)
Max. differential pressure (overpressure version)	+140 / +90 hPa (mbar) (50 / 60 Hz)	+190 / +180 hPa (mbar) (50 / 60 Hz)	+260 hPa (mbar) (50 / 60 Hz)
Nominal motor rating	4.0 / 4.6 kW (50 / 60 Hz)	5.5 / 6.3 kW (50 / 60 Hz)	7.5 / 8.6 kW (50 / 60 Hz)
Nominal motor speed	2850 / 3450 min ⁻¹ (50 / 60 Hz)	2850 / 3450 min ⁻¹ (50 / 60 Hz)	2850 / 3450 min ⁻¹ (50 / 60 Hz)
Noise level (ISO 3744)	70 / 74 dB(A) (50 / 60 Hz)	70 / 74 dB(A) (50 / 60 Hz)	70 / 74 dB(A) (50 / 60 Hz)
Weight approx.	112 kg	126 kg	128 kg
Dimensions (L x W x H)	495 x 498 x 514 mm	495 x 498 x 514 mm	495 x 498 x 514 mm
Gas inlet / outlet	G 2½" / G 2½"	G 2½" / G 2½"	G 2½" / G 2½"

	SAMOS SB 1100 D0	SAMOS SB 1100 D0	SAMOS SB 1100 D0
Nominal pumping speed/volume flow	1050 / 1250 m ³ /h (50 / 60 Hz)	1050 / 1250 m ³ /h (50 / 60 Hz)	1050 / 1250 m ³ /h (50 / 60 Hz)
Max. differential pressure (vacuum version)	-190 / -150 hPa (mbar) (50 / 60 Hz)	-290 / -270 hPa (mbar) (50 / 60 Hz)	-360 hPa (mbar) (50 / 60 Hz)
Max. differential pressure (overpressure version)	+190 / +140 hPa (mbar) (50 / 60 Hz)	+280 / +260 hPa (mbar) (50 / 60 Hz)	+460 / +420 hPa (mbar) (50 / 60 Hz)
Nominal motor rating	8.5 / 9.8 kW (50 / 60 Hz)	12.5 / 14.5 kW (50 / 60 Hz)	18.5 / 21.3 kW (50 / 60 Hz)

SAMOS SB 0710–1400 D0

Side channel blowers



VACUUM SOLUTIONS

	SAMOS SB 1100 D0	SAMOS SB 1100 D0	SAMOS SB 1100 D0
Nominal motor speed	2850 / 3450 min ⁻¹ (50 / 60 Hz)	2850 / 3450 min ⁻¹ (50 / 60 Hz)	2850 / 3450 min ⁻¹ (50 / 60 Hz)
Noise level (ISO 3744)	74 / 79 dB(A) (50 / 60 Hz)	74 / 79 dB(A) (50 / 60 Hz)	74 / 79 dB(A) (50 / 60 Hz)
Weight approx.	179 kg	198 kg	210 kg
Dimensions (L x W x H)	726 x 569 x 569 mm	726 x 569 x 569 mm	726 x 569 x 569 mm
Gas inlet / outlet	G 4" / G 4"	G 4" / G 4"	G 4" / G 4"

	SAMOS SB 1400 D0	SAMOS SB 1400 D0	SAMOS SB 1400 D0
Nominal pumping speed/volume flow	1350 / 1600 m ³ /h (50 / 60 Hz)	1350 / 1600 m ³ /h (50 / 60 Hz)	1350 / 1600 m ³ /h (50 / 60 Hz)
Max. differential pressure (vacuum version)	-120 / -80 hPa (mbar) (50 / 60 Hz)	-210 / -170 hPa (mbar) (50 / 60 Hz)	-320 / -340 hPa (mbar) (50 / 60 Hz)
Max. differential pressure (overpressure version)	+110 / +70 hPa (mbar) (50 / 60 Hz)	+200 / +150 hPa (mbar) (50 / 60 Hz)	+340 / +320 hPa (mbar) (50 / 60 Hz)
Nominal motor rating	8.5 / 9.8 kW (50 / 60 Hz)	12.5 / 14.5 kW (50 / 60 Hz)	18.5 / 21.3 kW (50 / 60 Hz)
Nominal motor speed	2850 / 3450 min ⁻¹ (50 / 60 Hz)	2850 / 3450 min ⁻¹ (50 / 60 Hz)	2850 / 3450 min ⁻¹ (50 / 60 Hz)
Noise level (ISO 3744)	75 / 80 dB(A) (50 / 60 Hz)	75 / 80 dB(A) (50 / 60 Hz)	75 / 80 dB(A) (50 / 60 Hz)
Weight approx.	179 kg	198 kg	210 kg
Dimensions (L x W x H)	726 x 569 x 569 mm	726 x 569 x 569 mm	726 x 569 x 569 mm
Gas inlet / outlet	G 4" / G 4"	G 4" / G 4"	G 4" / G 4"

DO YOU WANT TO KNOW MORE?

Get in touch with us directly!



CONTACT FORM