

DOLPHIN VL 0530-0800 A Total Recirculation

Liquid ring vacuum pump units



Robust

Proven technology, reliable operation, corrosion-free stainless steel impeller, extremely high vapor and particle tolerance, choice of cast iron (EN-GJL-200) or 316 grade stainless steel material housings, ATEX-certified version available (Cat. 1 (i/o) IIC, T4)

All-in-One

Unit with base frame, operating fluid separator, heat exchanger, control system, including inlet check valve, fresh liquid supply kit, level indicator with switches, temperature and pressure indicators and cavitation protection

Efficient

Full recirculation of operating fluid, low operating fluid consumption, recovery of condensed vapors and process gases, isolation of cooling liquid from operating fluid, operating fluids other than water possible

DOLPHIN VL 0530-0800 A Total Recirculation

Liquid ring vacuum pump units



Dimensional drawing

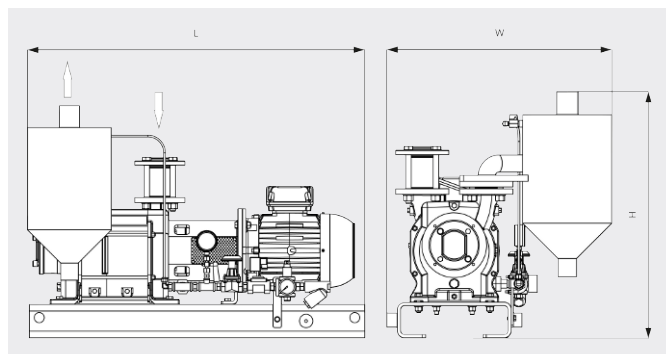

Dimensional drawing

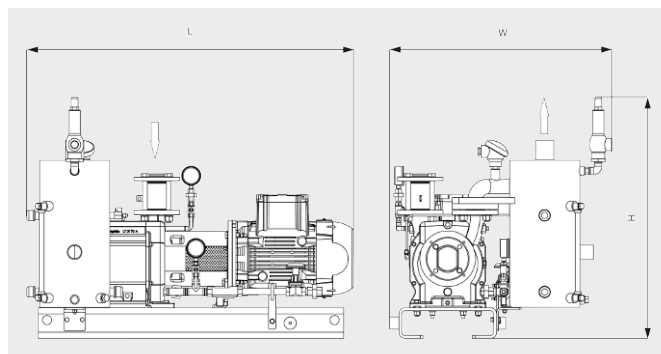

	DOLPHIN VL 0530 A Total Recirculation	DOLPHIN VL 0800 A Total Recirculation
Nominal pumping speed	405 / 551 m ³ /h (50 / 60 Hz)	722 / 867 m ³ /h (50 / 60 Hz)
Ultimate pressure	130 hPa (mbar) (50 / 60 Hz)	130 hPa (mbar) (50 / 60 Hz)
Nominal motor rating	11.0 / 15.0 kW (50 / 60 Hz)	18.5 / 22.0 kW (50 / 60 Hz)
Weight approx.	495 / 559 kg (Safe / ATEX)	573 / 659 kg (Safe / ATEX)
Dimensions (L x W x H)	1490 x 893 x 1129 / 1592 x 946 x 1248 mm (Safe / ATEX)	1679 x 973 x 1144 / 1761 1059 x 1431 mm (Safe / ATEX)
Gas inlet / outlet	G 2" / R 3"	G 2½" / R 4"

DO YOU WANT TO KNOW MORE?

Get in touch with us directly!
info@busch.ee or +372 568 13 203



CONTACT FORM



CALL NOW