



Installation and Operating Instructions



Vacuum Pumps

Mink MM 1402, 1502 AV

ATEX-Version Cat. 3(i) D



Busch Produktions GmbH
Schauinslandstr. 1
79689 Maulburg
Germany

Table of Contents

Preface	2
Technical Data	2
Product Description	3
Use	3
Principle of Operation.....	3
Cooling	3
Start Controls.....	4
Safety	4
Intended Use	4
Safety Notes	4
Noise Emission	4
Transport	4
Transport in Packaging	4
Transport without Packaging.....	4
Storage	5
Short-term Storage	5
Conservation.....	5
Installation and Commissioning	5
Installation prerequisites	5
Mounting Position and Space.....	5
Suction Connection	6
Gas Discharge	6
Electrical Connection / Controls.....	6
Installation.....	6
Mounting a NEMA-Motor with BoWex-Coupling	6
Mounting	6
Checking Synchronising Gear Oil.....	6
Connecting Electrically	7
Connection Scheme Three-Phase Motor	7
Connecting Lines/Pipes.....	8
Recording of Operational Parameters	8
Operating Notes.....	8
Use	8
Maintenance	9
Maintenance Schedule.....	9
Monthly	9
Every 3 Months:	9
Every 6 Months:	9
Every Year:	9
Every 20000 Operating Hours, At the Latest after 6 Years:10	
Changing Synchronising Gear Oil	10
Overhaul	10
Removal from Service	10
Temporary Removal from Service.....	10
Recommissioning.....	10
Dismantling and Disposal.....	10
Troubleshooting	12
Sectional Drawing	15
Spare Parts	16
Spare parts Kits	16
Oil	16
EC-Declaration of Conformity	17
Busch - All over the World in Industry	20

Preface

Congratulations on your purchase of the Busch vacuum pump. With watchful observation of the field's requirements, innovation and steady development Busch delivers modern vacuum and pressure solutions worldwide.

These operating instructions contain information for

- product description,
- safety,
- transport,
- storage,
- installation and commissioning,
- maintenance,
- overhaul,
- troubleshooting and
- spare parts

of the vacuum pump.

Version drive with integrated frequency inverter:

The drive with integrated frequency inverter is subject to a separate instruction manual.

For the purpose of these instructions, "handling" the vacuum pump means the transport, storage, installation, commissioning, influence on operating conditions, maintenance, troubleshooting and overhaul of the vacuum pump.

Prior to handling the vacuum pump these operating instructions shall be read and understood. If anything remains to be clarified please contact your Busch representative!

Keep these operating instructions and, if applicable, other pertinent operating instructions available on site.

Technical Data

Nominal suction capacity (50Hz/60Hz)	m ³ /h	MM 1402 AV: 400/470 MM 1502 AV: 500/570
Min allowed suction pressure	hPa (=mbar) abs.	200
Motor nominal rating (50Hz/60Hz)	kW	MM 1402 AV: 7.5/9.5 MM 1502 AV: 11/12.6
Motor nominal speed (50Hz/60Hz)	min ⁻¹	3000/3600
Sound pressure level (DIN EN ISO 2151) (50Hz/60Hz)	dB (A)	79/83
Ambient temperature range	°C	0 ... 40
Ambient pressure		Atmospheric pressure
Synchronisation gear oil quantity	l	1.2
Synchronisation gear oil filled ex-works		See name plate
Weight approx. (50Hz/60Hz)	kg	~290/~320



- a Cooling air outlet
- b Nameplate, vacuum pump
- c Directional arrow
- d Terminal box
- e Oil fill plug (=venting valve, underneath lid)
- f Eye bolt
- g Earth connection
- h Inlet air filter
- i Suction connection
- j Oil drain plug
- k Oil sight glass
- l Cooling air inlet
- m Gas discharge

Product Description

Use

The vacuum pump is intended for

- the suction
- of
- mixtures of dry non-aggressive and non-toxic gases and/or dust according to the identification on the nameplate of the vacuum pump (explanation see below).

Conveying media with a lower or higher density than air leads to an increased thermal and/or mechanical load on the vacuum pump and is permissible only after prior consultation with Busch.

Max. allowed temperature of the inlet gas: 40 °C

The classification on the vacuum pump is to be read as follows (interpretations of equipment categories and zones for information only; the relevant laws, directives and standards are literally binding; for temperature classes and explosion groups see E. Brandes, W. Möller "Sicherheitstechnische Kenngrößen, Band 1: Brennbare Flüssigkeiten und Gase", ISBN 3-89701-745-8 (or equivalent source)):

Ex II 3(i) D 125°C

Group II, for non-mining applications, in the process gas explosive atmosphere in the form of a cloud of combustible dust in air not likely to occur in normal operation but, if it does occur, will persist for a short period only (equipment category 3, for zone 22); maximum permissible surface temperature for the dust/air mixture in the process gas greater equal 125 °C (acc. to EN 50 281-2-1 or IEC 61241-2-1 resp.).

Not for explosive atmospheres consisting of mixtures with air of flammable substances in the form of gas.

Not for potentially explosive atmospheres in the environment.

The use of the supplied inlet air filter (h) with equipotential bonding (g) including the pertinent filter cartridge with equipotential bonding is required.

The approval for use in potentially explosive atmospheres is valid for the vacuum pump together with the supplied inlet air filter (h). The approval is void if the system is altered or if the scheduled maintenance is not complied with. Maintenance must be performed by specifically instructed personnel only.

Max. permissible number of startings per hour: 12

Vacuum pumps MM 1402, 1502 AV ATEX are thermally suitable for continuous operation at intake pressures down to 200 hPa abs (200 mbar abs). By means of process control and/or vacuum relief valves it must be made sure that the minimum allowed intake pressure will not be underrun.

Principle of Operation

The vacuum pump works on the claw principle.

The components are dimensioned such, that on the one hand there is never contact between the two claws or between a claw and the cylinder, on the other hand the gaps are small enough to keep the clearance loss between the chambers low.

In order to avoid the suction of solids, the vacuum pump is equipped with a screen in the suction connection.

In order to avoid reverse rotation after switching off, the vacuum pump is equipped with a non-return valve.

The vacuum pump compresses the inlet gas absolutely oil-free. A lubrication of the pump chamber is neither necessary nor allowed.

Cooling

The vacuum pump is cooled by

- radiation of heat from the surface of the vacuum pump
- the air flow from the fan wheel of the drive motor

- the process gas
- the air flow from the fan wheel on the shaft of the vacuum pump

Start Controls

The vacuum pump comes without start controls. The control of the vacuum pump is to be provided in the course of installation.

Safety

Intended Use

Definition: For the purpose of these instructions, "handling" the vacuum pump means the transport, storage, installation, commissioning, influence on operating conditions, maintenance, troubleshooting and overhaul of the vacuum.

The vacuum pump is intended for industrial use. It shall be handled only by qualified personnel.

The allowed media and operational limits (→ page 3: Product Description) and the installation prerequisites (→ page 5: Installation Prerequisites) of the vacuum pump shall be observed both by the manufacturer of the machinery into which the vacuum pump is to be incorporated and by the operator.

The maintenance instructions shall be observed.

In particular the intended use in potentially explosive areas, i.e. either inside the vacuum pump or in its adjacency potentially explosive atmosphere can occur, requires that the vacuum pump is equipped accordingly and carries the Ex-mark and that the associated documentation acc. to the directive 94/9/EC is available.

Prior to handling the vacuum pump these installation and operating instructions shall be read and understood. If anything remains to be clarified please contact your Busch representative!

Safety Notes

The vacuum pump has been designed and manufactured according to state-of-the-art methods. Nevertheless, residual risks may remain. These operating instructions highlight potential hazards where appropriate. Safety notes are tagged with one of the keywords DANGER, WARNING and CAUTION as follows:



DANGER

Disregard of this safety note will always lead to accidents with fatal or serious injuries.



WARNING

Disregard of this safety note may lead to accidents with fatal or serious injuries.



CAUTION

Disregard of this safety note may lead to accidents with minor injuries or property damage.

Noise Emission

For the sound pressure level in free field according to EN ISO 2151 → page 2: Technical Data.



CAUTION

The vacuum pump emits noise of high intensity in a narrow band.

Risk of damage to the hearing.

Persons staying in the vicinity of a non noise insulated vacuum pump over extended periods shall wear ear protection.

Transport

Transport in Packaging

Packed on a pallet the vacuum pump is to be transported with a forklift.

Transport without Packaging

In case the vacuum pump is packed in a cardboard box with inflated cushions:

- ◆ Remove the inflated cushions from the box

In case the vacuum pump is packed in a cardboard box cushioned with rolled corrugated cardboard:

- ◆ Remove the corrugated cardboard from the box

In case the vacuum pump is laid in foam:

- ◆ Remove the foam

In case the vacuum pump is bolted to a pallet or a base plate:

- ◆ Remove the bolting between the vacuum pump and the pallet/base plate

In case the vacuum pump is fastened to the pallet by means of tightening straps:

- ◆ Remove the tightening straps



CAUTION

Do not walk, stand or work under suspended loads.

- Make sure that the eyebolt (f) is in faultless condition (replace a damaged, e.g. bent eyebolt with a new one)
- Make sure that the eye bolt (f) is fully screwed in and tightened by hand
- Attach lifting gear securely to the eyebolt (f) on the synchronising gear

When the vacuum pump is equipped with a very heavy drive motor and would hang very inclined (>10°) on the synchronising gear eyebolt alone:

- ◆ Attach lifting gear securely to the eyebolts on the synchronising gear (f) and the drive motor

In case the drive motor comes without an eyebolt or the eyebolt on the drive motor is located at an unfavourable position:

- ◆ Loop a belt/rope with suitable length and strength around the flange of the drive motor
- Attach the lifting gear to a crane hook with safety latch
- Lift the vacuum pump with a crane

In case the vacuum pump was bolted to a pallet or a base plate:

- ◆ Remove the stud bolts from the rubber feet

Storage

Short-term Storage

- Make sure that the suction connection and the gas discharge are closed (leave the provided plugs in)
- Store the vacuum pump
 - If possible in original packaging,
 - indoors,
 - dry,
 - dust free and
 - vibration free.

Conservation

In case of adverse ambient conditions (e.g. aggressive atmosphere, frequent temperature changes) conserve the vacuum pump immediately. In case of favourable ambient conditions conserve the vacuum pump if a storage of more than 3 months is scheduled.

- Make sure that all ports are firmly closed; seal all ports that are not sealed with PTFE-tape, gaskets or o-rings with adhesive tape

Note: VCI stands for “volatile corrosion inhibitor”. VCI-products (film, paper, cardboard, foam) evaporate a substance that condenses in molecular thickness on the packed good and by its electro-chemical properties effectively suppresses corrosion on metallic surfaces. However, VCI-products may attack the surfaces of plastics and elastomers. Seek advice from your local packaging dealer! Busch uses CORTEC VCI 126 R film for the overseas packaging of large equipment.

- Wrap the vacuum pump in VCI film
- Store the vacuum pump
 - If possible in original packaging,
 - indoors,
 - dry,
 - dust free and
 - vibration free.

For commissioning after conservation:

- Make sure that all remains of adhesive tape are removed from the ports
- Commission the vacuum pump as described in the chapter Installation and Commissioning (→ page 5)

Installation and Commissioning

Installation prerequisites



CAUTION

In case of non-compliance with the installation prerequisites, particularly in case of insufficient cooling:

Risk of damage or destruction of the vacuum pump and adjoining plant components!

Risk of injury!

The installation prerequisites must be complied with.

- Make sure that the integration of the vacuum pump is carried out such that the essential safety requirements of the Machine Directive 2006/42/EC are complied with (in the responsibility of the designer of the machinery into which the vacuum pump is to be incorporated; → page 16: note in the EC-Declaration of Conformity)

Mounting Position and Space

- Make sure that the environment of the vacuum pump is not potentially explosive
- Make sure that the following ambient conditions will be complied with:
 - ambient temperature: 0 ... 40 °C
 - ambient pressure: atmospheric
- Make sure that the environmental conditions comply with the protection class of the drive motor (according to the nameplate)
- Make sure that the vacuum pump will be placed or mounted horizontally
- Make sure that the base for placement / mounting base is even
- Make sure that in order to warrant a sufficient cooling there will be a clearance of minimum 1 m between the vacuum pump and nearby walls
- Make sure that no heat sensitive parts (plastics, wood, cardboard, paper, electronics) will touch the surface of the vacuum pump
- Make sure that the installation space or location is vented such that a sufficient cooling of the vacuum pump is warranted



CAUTION

During operation the surface of the vacuum pump may reach temperatures of more than 70 °C.

Risk of burns!

- Make sure that the vacuum pump will not be touched inadvertently during operation, provide a guard if appropriate
- Make sure that the sight glass (k, 76) of the synchronising gear will remain accessible

In case the synchronising gear oil change is planned to be carried out on location:

- ♦ Make sure that the drain port (j, 80) and the filling port (e, 72) of the synchronising gear will remain easily accessible

Suction Connection



CAUTION

Intruding foreign objects or liquids can destroy the vacuum pump.

- Make sure that the suction line will be connected via the supplied inlet air filter (h) (with equipotential bonding)
- Make sure that the suction line fits to the suction connection (i) of the vacuum pump
- Make sure that the pipe is made from electrically conductive material and equipped with an equipotential bonding connection (execution according to EN 61241-14 or equivalent national or local regulations)
- Make sure that the pipe will cause no stress on the vacuum pump's connection, if necessary use an expansion joint
- Make sure that the line size of the suction line over the entire length is at least as large as the suction connection of the vacuum pump

In case the length of the suction line exceeds 2 m it is prudent to use larger line sizes in order to avoid a loss of efficiency and an overload of the vacuum pump. Seek advice from your Busch representative!

In case the vacuum pump shall be maintained after shutdown of the vacuum pump:

- ◆ Provide a manual or automatic operated valve (= non-return valve) in the suction line
- Make sure that the suction line does not contain foreign objects, e.g. welding scales

Gas Discharge

The discharged gas must flow without obstruction. It is not permitted to shut off or throttle the discharge line or to use it as a pressurised air source.

- Make sure that the discharge line fits to the gas discharge (m) of the vacuum pump
- Make sure that the pipe will cause no stress on the vacuum pump's connection, if necessary use an expansion joint
- Make sure that the line size of the discharge line over the entire length is at least 2"

In case the length of the discharge line exceeds 2 m it is prudent to use larger line sizes in order to avoid a loss of efficiency and an overload of the vacuum pump. Seek advice from your Busch representative!

- Make sure that the discharge line either slopes away from the vacuum pump or provide a liquid separator or a drip leg with a drain cock, so that no liquids can back up into the vacuum pump

Electrical Connection / Controls

- Make sure that the stipulations acc. to the EMC-Directive 2004/108/EC and Low-Voltage-Directive 2006/95/EC as well as the EN-standards, electrical and occupational safety directives and the local or national regulations, respectively, are complied with (this is the responsibility of the designer of the machinery into which the vacuum pump is to be incorporated; → page 16: note in the EC-Declaration of Conformity).
- Make sure that the power supply for the drive motor is compatible with the data on the nameplate of the drive motor
- Make sure that an overload protection according to EN 60204-1 is provided for the drive motor

- Make sure that the drive of the vacuum pump will not be affected by electric or electromagnetic disturbance from the mains; if necessary seek advice from the Busch service

In case of mobile installation:

- ◆ Provide the electrical connection with grommets that serve as strain-relief
- Make sure that an earth point is available for connection to the inlet air filter (h)
- Electrical circuits in zone 1 (outside) shall be executed intrinsically safe in protection class *ib* acc. to EN 60079-11.

Installation

Mounting a NEMA-Motor with BoWex-Coupling

For certain markets the vacuum pump is available without motor, but with a NEMA-adaptor flange and a BoWex-coupling.

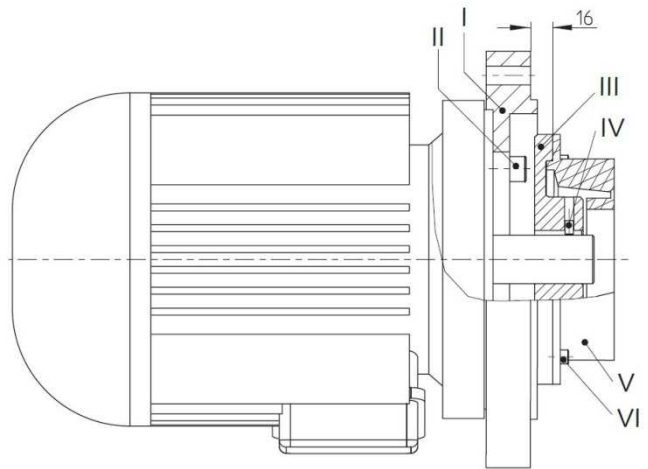

- Remove the NEMA-adaptor flange (I) from the vacuum pump
- Pull the elastomer part (V) together with the hub (III) off the shaft of the vacuum pump
- Mount the NEMA-adaptor flange (I) on the motor (the bolts (II) are not part of the Busch scope of delivery)
- Undo the cylinder screws (VI) and remove the elastomer part (V) from the hub (III)
- Make sure that the parallel key is inserted into the motor shaft
- Push the hub (III) onto the motor shaft such that the mounting face of the hub (III) will be located 16 ± 1 mm before the mounting face of the NEMA-adaptor flange (I) (→ sketch)
- Fasten the hub (III) on the motor shaft using the set screw (IV)
- Apply thread locking agent on the threads of the cylinder screws (VI)
- Mount the elastomer part (V) on the hub (III) with the cylinder screws (VI) and tighten the cylinder screws with 14 Nm
- Mount the motor on the vacuum pump

Mounting

- Make sure that the installation prerequisites (→ page 5) are complied with
- Set down or mount the vacuum pump at its location

Checking Synchronising Gear Oil

The vacuum pump is delivered with oil filled synchronising gear.

The level shall be slightly above the middle of the sight glass (k, 76).

- Check on the sight glass (k, 76) that the proper amount of oil is filled

Connecting Electrically



WARNING

Risk of electrical shock, risk of damage to equipment.

Electrical installation work must only be executed by qualified personnel that knows and observes the following regulations:

- IEC 364 or CENELEC HD 384 or DIN VDE 0100, respectively,
- IEC-Report 664 or DIN VDE 0110,
- BGV A2 (VBG 4) or corresponding national accident prevention regulation.



CAUTION

The connection schemes given below are typical. Depending on the specific order or for certain markets deviating connection schemes may apply.

Risk of damage to the drive motor!

The inside of the terminal box shall be checked for drive motor connection instructions/schemes.

Note: For the connection of a drive with integrated frequency inverter see the separate operating instructions!

- Electrically connect the drive motor
- Connect the protective earth conductor

Connection Scheme Three-Phase Motor

Delta connection (low voltage):

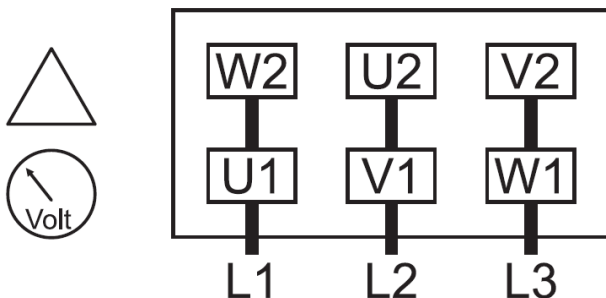

Star connection (high voltage):

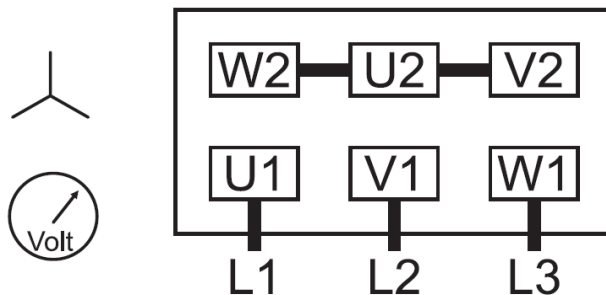

Double star connection, multi-voltage motor with 9 terminals (low voltage):

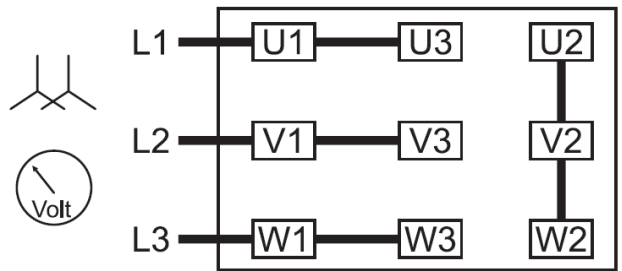

Star connection, multi-voltage motor with 9 terminals (high voltage):

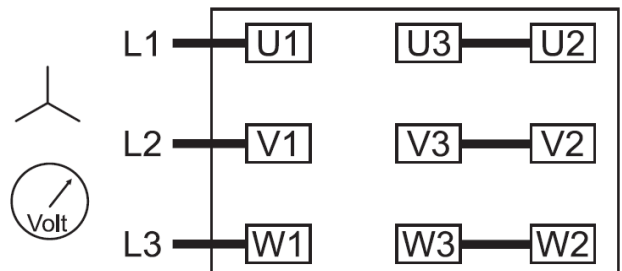

Double star connection, multi-voltage motor with 12 terminals (low voltage):

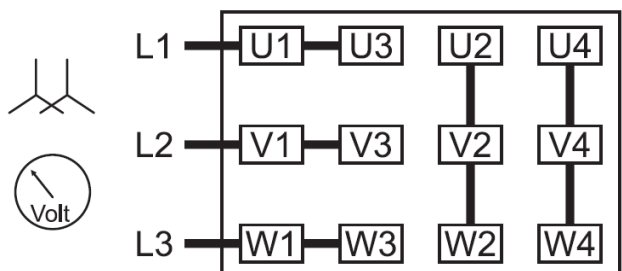

Delta connection, multi-voltage motor with 12 terminals (middle voltage):

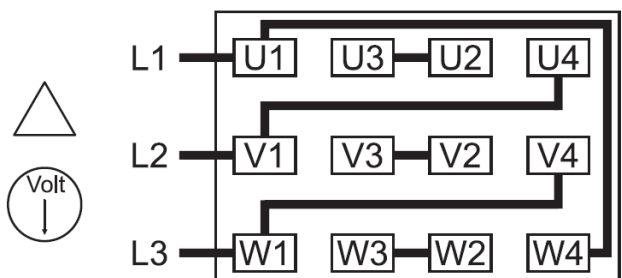

Star connection, multi-voltage motor with 12 terminals (high voltage):

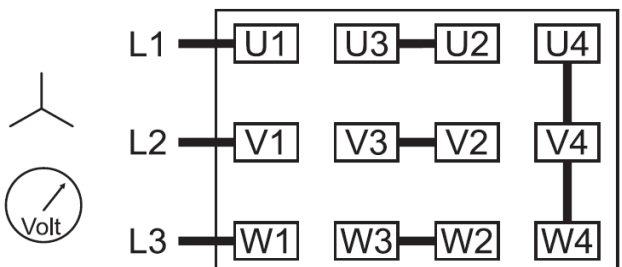



CAUTION

Operation in the wrong direction of rotation can destroy the vacuum pump in short time.

Risk of explosion!

Prior to starting-up it must be made sure that the vacuum pump is operated in the proper direction (clockwise rotating field).

Version with three-phase motor:

- ◆ Determine the intended direction of rotation with the arrow (c) (stuck on or cast)
- ◆ "Bump" the drive motor
- ◆ Watch the fan wheel of the drive motor and determine the direction of rotation just before the fan wheel stops

If the rotation must be changed:

- ◆ Switch any two of the drive motor wires (three-phase motor)
- Connect the housing of the inlet air filter to the earth point with an earth cable

Connecting Lines/Pipes

- Connect the suction line
- Connect the discharge line

Installation without discharge line:

- ◆ Make sure that the gas discharge (m) is open
- Make sure that all provided covers, guards, hoods etc. are mounted
- Make sure that the cooling air inlets and outlets are not covered or obstructed and that the cooling air flow is not affected adversely in any other way

Recording of Operational Parameters

As soon as the vacuum pump is operated under normal operating conditions:

- Measure the drive motor current and record it as reference for future maintenance and troubleshooting work

Operating Notes

Use



WARNING

The vacuum pump is designed for operation under the conditions described below.

In case of disregard risk of explosion!

The vacuum pump must only be operated under the conditions described below.



WARNING

Operating a faulty vacuum pump puts the explosion safety at risk.

Risk of explosion!

The vacuum pump must only be operated in faultless condition. A faulty vacuum pump must immediately be removed from service.

The vacuum pump is intended for

- the suction

of

- mixtures of dry non-aggressive and non-toxic gases and/or dust according to the identification on the nameplate of the vacuum pump (explanation see below).

Conveying media with a lower or higher density than air leads to an increased thermal and/or mechanical load on the vacuum pump and is permissible only after prior consultation with Busch.

Max. allowed temperature of the inlet gas: 40 °C

The classification on the vacuum pump is to be read as follows (interpretations of equipment categories and zones for information only; the relevant laws, directives and standards are literally binding; for temperature classes and explosion groups see E. Brandes, W. Möller "Sicherheitstechnische Kenngrößen, Band 1: Brennbare Flüssigkeiten und Gase", ISBN 3-89701-745-8 (or equivalent source)):



II 3(i) D 125°C

Group II, for non-mining applications, in the process gas explosive atmosphere in the form of a cloud of combustible dust in air not likely to occur in normal operation but, if it does occur, will persist for a short period only (equipment category 3, for zone 22); maximum permissible surface temperature for the dust/air mixture in the process gas greater equal 125 °C (acc. to EN 50 281-2-1 or IEC 61241-2-1 resp.).

Not for explosive atmospheres consisting of mixtures with air of flammable substances in the form of gas.

Not for potentially explosive atmospheres in the environment.

The use of the supplied inlet air filter (h) with equipotential bonding (g) including the pertinent filter cartridge with equipotential bonding is required.

The approval for use in potentially explosive atmospheres is valid for the vacuum pump together with the supplied inlet air filter (h). The approval is void if the system is altered or if the scheduled maintenance is not complied with. Maintenance must be performed by specifically instructed personnel only.

Max. permissible number of startings per hour: 12

Vacuum pumps MM 1402, 1502 AV ATEX are thermally suitable for continuous operation at intake pressures down to 200 hPa abs (200 mbar abs). By means of process control and/or vacuum relief valves it must be made sure that the minimum allowed intake pressure will not be underrun.



CAUTION

During operation the surface of the vacuum pump may reach temperatures of more than 70 °C.

Risk of burns!

The vacuum pump shall be protected against contact during operation, it shall cool down prior to a required contact or heat protection gloves shall be worn.



CAUTION

The vacuum pump emits noise of high intensity in a narrow band.

Risk of damage to the hearing.

Persons staying in the vicinity of a non noise insulated vacuum pump over extended periods shall wear ear protection.

- Make sure that all provided covers, guards, hoods etc. remain mounted
- Make sure that protective devices will not be disabled
- Make sure that cooling air inlets and outlets will not be covered or obstructed and that the cooling air flow will not be affected adversely in any other way
- Make sure that the installation prerequisites (→ page 5: Installation Prerequisites) are complied with and will remain complied with, particularly that a sufficient cooling will be ensured

Maintenance



WARNING

The approval of the vacuum pump for use in potentially explosive areas remains valid only if the maintenance is conducted regularly according to the maintenance schedule below and genuine spare parts and consumables, approved for use in potentially explosive areas by Busch, are used exclusively.

Maintenance work must be executed by qualified personnel, specially instructed in the maintenance of this type of vacuum pump by Busch.



DANGER

In case the vacuum pump conveyed gas that was contaminated with foreign materials which are dangerous to health, harmful material can reside in filters.

Danger to health during inspection, cleaning or replacement of filters.

Danger to the environment.

Personal protective equipment must be worn during the handling of contaminated filters.

Contaminated filters are special waste and must be disposed of separately in compliance with applicable regulations.



CAUTION

During operation the surface of the vacuum pump may reach temperatures of more than 70 °C.

Risk of burns!

- Prior to disconnecting connections make sure that the connected pipes/lines are vented to atmospheric pressure

Maintenance Schedule

Note: The maintenance intervals depend very much on the individual operating conditions. The intervals given below shall be considered as starting values which should be shortened or extended as appropriate. Particularly heavy duty operation, such like high dust loads in the environment or in the process gas, other contaminations or ingress of process material, can make it necessary to shorten the maintenance intervals significantly.

Monthly

- Make sure that the vacuum pump is shut down and locked against inadvertent start up
- Check the inlet air filter (h), if necessary replace

In case of operation in a dusty environment:

- ♦ Clean as described under → page 9: Every 6 Months

Every 3 Months:

- Make sure that the vacuum pump is shut down and locked against inadvertent start up

- Check the level and the colour of the synchronising gear oil

The level shall be slightly above the middle of the sight glass (j, 76).

The level of the synchronising gear should stay constant over the lifetime of the oil. If the level does fall, the gear is leaky and the vacuum pump requires repair (Busch service).

Every 6 Months:

- Make sure that the housing is free from dust and dirt, clean if necessary
- Make sure that the vacuum pump is shut down and locked against inadvertent start up
- Remove the acoustic enclosure

Note: Make sure that the foam mats do **n o t** get soaked with water

Note: Any kind of deposit on the vacuum pump compromises the explosion safety of the vacuum pump.

- Clean the fan cowlings, fan wheels, the ventilation grilles and cooling fins
- Mount the acoustic enclosure

Every Year:

- Make sure that the vacuum pump is shut down and locked against inadvertent start up
- Replace the inlet air filter (h)
- Check the inlet screen, clean if necessary

Note: As there is an inlet air filter (h) upstream the inlet screen, the inlet screen should not show soiling. A soiled inlet screen indicates that the filter is either broken through or improperly inserted.



WARNING

A soiled screen indicates the improper function of the filter. The pump chamber contains material that can compromise the explosion safety of the vacuum pump.

Risk of explosion!

If the inlet screen is soiled, the vacuum pump must be cleaned by Busch service.

Every 20000 Operating Hours, At the Latest after 6 Years:

Note: The change interval of 20000 operating hours is valid for the gear oil approved by Busch (see name plate). The change interval depends very much on the operating conditions. Borderline operation may reduce the change interval down to approximately 5000 operating hours or 6 months. Other gear oils may reduce the change interval.

- Change the synchronising gear oil

Changing Synchronising Gear Oil

- Make sure that the vacuum pump is shut down and locked against inadvertent start up

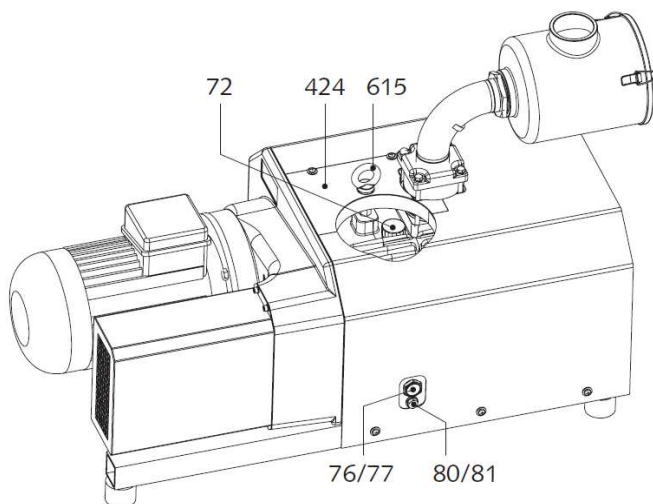

- Remove the eyebolt (f, 615)
- Remove the lid (424)
- Undo the venting valve (e, 72) for venting
- Place a drain tray underneath the drain plug (j, 80)
- Open the drain plug (j, 80) and drain the oil
- Make sure that the seal ring on the drain plug (j, 80) is serviceable, replace if necessary
- Firmly reinsert the drain plug (j, 80) together with the seal ring
- Remove the venting valve (e, 72) completely
- Fill in new gear oil until the level is slightly above the middle of the sight glass (k, 76)
- Make sure that the seal ring on the venting valve (e, 72) is undamaged, if necessary replace the venting valve (e, 72)
- Firmly reinsert the venting valve (e, 72) together with the seal ring
- Mount the lid (424)
- Reinsert the eyebolt (f, 615)
- Dispose of the used oil in compliance with applicable regulations

Overhaul



WARNING

Improper work on the vacuum pump puts the operating safety at risk.

Risk of explosion!

Approval for operation will be void!

Any dismantling of the vacuum pump that is beyond of what is described in this manual must be done by specially trained Busch service personnel only.



DANGER

In case the vacuum pump conveyed gas that was contaminated with foreign materials which are dangerous to health, harmful material can reside in pores, gaps and internal spaces of the vacuum pump.

Danger to health during dismantling of the vacuum pump.

Danger to the environment.

Prior to shipping the vacuum pump shall be decontaminated as good as possible and the contamination status shall be stated in a "Declaration of Contamination" (form downloadable from www.busch-vacuum.com).

Busch service will only accept vacuum pumps that come with a completely filled in and legally binding signed "Declaration of Contamination" (form downloadable from www.busch-vacuum.com).

Removal from Service

Temporary Removal from Service

- Prior disconnecting pipes/lines make sure that all pipes/lines are vented to atmospheric pressure

Recommissioning

- Observe the chapter Installation and Commissioning (→ page 5)

Dismantling and Disposal



DANGER

In case the vacuum pump conveyed gas that was contaminated with foreign materials which are dangerous to health, harmful material can reside in pores, gaps and internal spaces of the vacuum pump.

Danger to health during dismantling of the vacuum pump.

Danger to the environment.

During dismantling of the vacuum pump personal protective equipment must be worn.

The vacuum pump must be decontaminated prior to disposal.

- Drain the oil
- Make sure that materials and components to be treated as special waste have been separated from the vacuum pump

- Make sure that the vacuum pump is not contaminated with harmful foreign material

According to the best knowledge at the time of printing of this manual the materials used for the manufacture of the vacuum pump involve no risk.

- Dispose of the used oil in compliance with applicable regulations
- Dispose of the vacuum pump as scrap metal

Troubleshooting



WARNING

Risk of electrical shock, risk of damage to equipment.

Electrical installation work must only be executed by qualified personnel that knows and observes the following regulations:

- IEC 364 or CENELEC HD 384 or DIN VDE 0100, respectively,
- IEC-Report 664 or DIN VDE 0110,
- BGV A2 (VBG 4) or corresponding national accident prevention regulation.



CAUTION

During operation the surface of the vacuum pump may reach temperatures of more than 70 °C.

Risk of burns!

Let the vacuum pump cool down prior to a required contact or wear heat protection gloves.

Problem	Possible Cause	Remedy
The vacuum pump does not reach the usual pressure The drive motor draws a too high current (compare with initial value after commissioning) Evacuation of the system takes too long	The vacuum system or suction line is not leak-tight	Check the hose or pipe connections for possible leak
	In case a vacuum relief valve/regulating system is installed: The vacuum relief valve/regulating system is misadjusted or defective	Adjust, repair or replace, respectively
	The screen in the suction connection is partially clogged	Clean the screen If cleaning is required too frequently install a filter upstream
	The filter on the suction connection (g) is partially clogged	Clean or replace the inlet air filter, respectively
	Partial clogging in the suction, discharge or pressure line	Remove the clogging
	Long suction, discharge or pressure line with too small diameter	Use larger diameter
	The valve disk of the inlet non-return valve is stuck in closed or partially open position	Disassemble the inlet, clean the screen and the valve as required and reassemble
	Internal parts are worn or damaged	Repair the vacuum pump (Busch service)
The gas conveyed by the vacuum pump smells displeasing	Process components evaporating under vacuum	Check the process, if applicable
The vacuum pump does not start	The drive motor is not supplied with the correct voltage or is overloaded	Supply the drive motor with the correct voltage
	The drive motor starter overload protection is too small or trip level is too low	Compare the trip level of the drive motor starter overload protection with the data on the nameplate, correct if necessary In case of high ambient temperature: set the trip level of the drive motor starter overload protection 5 percent above the nominal drive motor current
	One of the fuses has blown	Check the fuses
	The connection cable is too small or too long causing a voltage drop at the vacuum pump	Use sufficiently dimensioned cable

	The vacuum pump or the drive motor is blocked	<p>Make sure the drive motor is connected from the power supply</p> <p>Remove the fan cover</p> <p>Try to turn the drive motor with the vacuum pump by hand</p> <p>If the unit is still frozen: remove the drive motor and check the drive motor and the vacuum pump separately</p> <p>If the vacuum pump is blocked: Repair the vacuum pump (Busch service)</p>
	The drive motor is defective	<p>Replace the drive motor (Busch service)</p> <p>(the proper function of the fan wheel requires the precise adjustment of the coupling on the motor shaft and the pump shaft; therefore the motor can be mounted by the Busch service only)</p>
The vacuum pump is blocked	Solid foreign matter has entered the vacuum pump	<p>Repair the vacuum pump (Busch service)</p> <p>Make sure the suction line is equipped with a screen</p> <p>If necessary additionally provide a filter</p>
	Corrosion in the vacuum pump from remaining condensate	<p>Repair the vacuum pump (Busch service)</p> <p>Check the process</p>
	The vacuum pump was run in the wrong direction	<p>Repair the vacuum pump (Busch service)</p> <p>When connecting the vacuum pump make sure the vacuum pump will run in the correct direction (→ page 7 Installation)</p>
The drive motor is running, but the vacuum pump stands still	The coupling between the drive motor and the vacuum pump is defective	<p>Replace the coupling element</p> <p>(the proper function of the fan wheel requires the precise adjustment of the coupling on the motor shaft and the pump shaft; therefore the motor can be mounted by the Busch service only)</p>
<p>The vacuum pump starts, but labours or runs noisily or rattles</p> <p>The drive motor draws a too high current (compare with initial value after commissioning)</p>	<p>Loose connection(s) in the drive motor terminal box</p> <p>Not all drive motors coils are properly connected</p> <p>The drive motor operates on two phases only</p>	<p>Check the proper connection of the wires against the connection diagram</p> <p>(particularly on motors with six coils)</p> <p>Tighten or replace loose connections</p>
	The vacuum pump runs in the wrong direction	Verification and rectification → page 6: Installation and Commissioning
	<p>Foreign objects in the vacuum pump</p> <p>Stuck bearings</p>	Repair the vacuum pump (Busch service)
The vacuum pump runs very noisily	Defective bearings	Repair the vacuum pump (Busch service)
	Worn coupling element	Replace the coupling element
	Low oil level in the synchronising gear	<p>The synchronising gear is leaky</p> <p>Repair the vacuum pump (Busch service)</p>
	Synchronising gear damaged due to operation with low oil level	Repair the vacuum pump (Busch service)

The vacuum pump is very hot	Insufficient air ventilation	<p>Make sure that the cooling of the vacuum pump is not impeded by dust/dirt</p> <p>Clean the fan cowlings, the fan wheels, the ventilation grilles and the cooling fins</p> <p>Install the vacuum pump in a narrow space only if sufficient ventilation is ensured</p>
	Ambient temperature too high	Observe the permitted ambient temperatures
	Temperature of the inlet gas too high	Observe the permitted temperatures for the inlet gas
	Mains frequency or voltage outside tolerance range	Provide a more stable power supply
	<p>Partial clogging of filters or screens</p> <p>Partial clogging in the suction, discharge or pressure line</p>	Remove the clogging
	Long suction, discharge or pressure line with too small diameter	Use larger diameter

Sectional Drawing

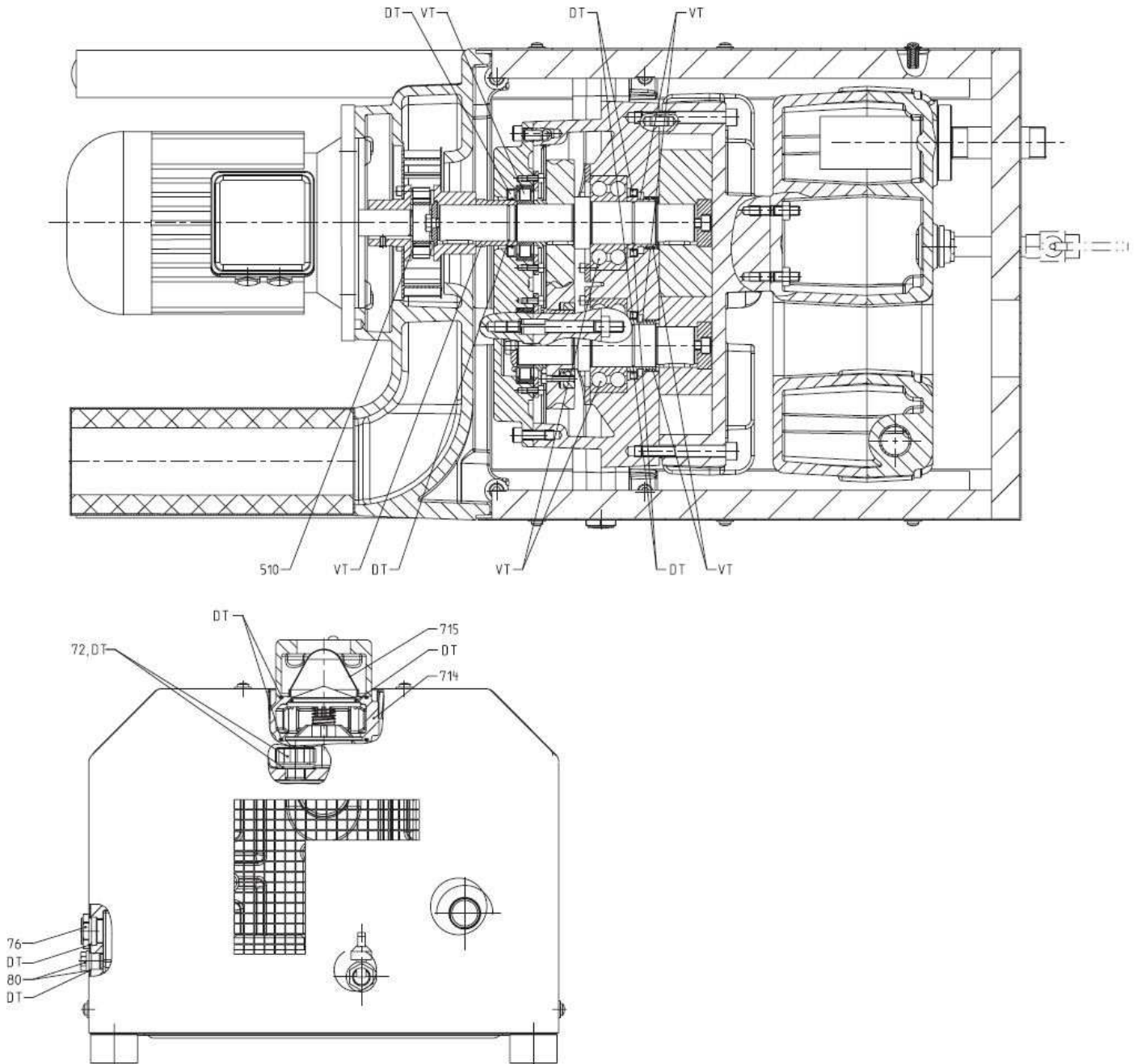

Spare Parts

Note: When ordering spare parts or accessories acc. to the table below please always quote the type ("Type") and the serial no. ("No") of the vacuum pump. this will allow Busch service to check if the vacuum pump is compatible with a modified or improved part.

The exclusive use of the genuine spare parts and consumables is a prerequisite for the proper function of the vacuum pump and for the granting of warranty, guarantee or goodwill.

Your point of contact for service and spare parts in the United Kingdom:

Busch (UK) Ltd.
Hortonwood 30-35
Telford
Shropshire
TF1 7YB
Tel: 01952 677 432
Fax: 01952 677 423

Your point of contact for service and spare parts in Ireland:

Busch Ireland Ltd.
A10-11 Howth Junction Business Centre
Kilbarrack, Dublin 5
Tel: +353 (0)1 8321466
Fax: +353 (0)1 8321470

Your point of contact for service and spare parts in the USA:

Busch Inc.
516-B Viking Drive
Virginia Beach, VA 23452
Tel: 1-800-USA-PUMP (872-7867)

Your point of contact for service and spare parts in Canada:

Busch Vacuum Technics Inc.
1740, Boulevard Lionel Bertrand
Boisbriand (Montréal)
Québec J7H 1N7
Tel: 450 435 6899
Fax: 450 430 5132

Your point of contact for service and spare parts in Australia:

Busch Australia Pty. Ltd.
30 Lakeside Drive
Broadmeadows, Vic. 3047
Tel: (03) 93 55 06 00
Fax: (03) 93 55 06 99

Your point of contact for service and spare parts in New Zealand:

Busch New Zealand Ltd.
Unit D, Arrenway Drive
Albany, Auckland 1311
P O Box 302696
North Harbour, Auckland 1330
Tel: 0-9-414 7782
Fax: 0-9-414 7783

Find the list of Busch companies all over the world (by the time of the publication of these installation and operating instructions) on → page 20 (rear cover page).

Find the up-to-date list of Busch companies and agencies all over the world on the internet at www.busch-vacuum.com.

Pos.	Part	Qty	Part no.
72	Venting valve (=oil fill plug) with seal ring	1	0543 138 026
76	Sight glass	1	0583 000 001
77	Seal ring for sight glass	1	0480 000 271
80	Plug with magnet and seal ring	1	0415 134 870
81	Seal ring for plug with magnet	1	0482 137 352

714	Inlet flange, lower part, with non-return valve	1	0915 000 672
715	Screen	1	0534 000 094
-	Paper cartridge for air filter, ATEX	1	on request
-	Polyester cartridge for air filter, ATEX	1	0532 541 197

Spare parts Kits

Spare parts kit	Part no.
Overhaul kit (incl. set of seals, marking "VT" and "DT"; insert for flexible coupling for Rotex only)	0993 156 913
Set of seals (marking "DT")	0990 156 917

Oil

For Busch vacuum pumps and compressors the standard approved synchronising gear oil is VS 150. Depending on specific orders, the type of synchronising gear oil may vary.

Denomination	VS 150
ISO-VG	150
Base	PAO
Density [g/cm ³]	0.846
Kinematic viscosity at 40 °C [mm ² /s]	150
Kinematic viscosity at 100 °C [mm ² /s]	19.8
Flashpoint [°C]	236
Pourpoint [°C]	-54
Part number 1 l packaging	0831 164 883
Filling quantity, approx. [l]	1.2

EC-Declaration of Conformity

Note: This Declaration of Conformity and the CE-mark affixed to the nameplate are valid for the machine within the Busch scope of delivery. This Declaration of Conformity is issued under the sole responsibility of the manufacturer.
When this machine is integrated into a superordinate machinery the manufacturer of the superordinate machinery (this can be the operating company, too) must conduct the conformity assessment process for the superordinate machine or plant, issue the Declaration of Conformity for it and affix the CE-mark.

We

Busch Produktions GmbH
Schauinslandstr. 1
79689 Maulburg
Germany

Declare that the vacuum pumps **MM 'ATEX Cat. 3(i) D' 1402, 1502 AV**

with a serial number from **D1601...** to **D1752...**

has (have) been manufactured in accordance with the European Directives:

- 'Machinery' 2006/42/EC
- 'ATEX Directive' 94/9/EC (up to 19th April 2016) or 2014/34/EU (from 20th April 2016) for use in potentially explosive areas according to classification written on the machine nameplate
- 'Electromagnetic Compatibility' 2014/30/EU
- 'RoHS' 2011/65/EU, restriction of the use of certain hazardous substances in electrical and electronic equipment

and following the standards.

Standard	Title of the Standard
EN ISO 12100: 2010	Safety of machinery – Basic concepts, General principles for design –Risk assessment and risk reduction
EN ISO 13857: 2008	Safety of machinery - Safety distances to prevent hazard zones being reached by the upper and lower limbs
EN 1012-1: 2010 EN 1012-2: 1996 + A1: 2009	Compressors and vacuum pumps - Safety requirements - Part 1 and Part 2
EN ISO 2151: 2008	Acoustics - Noise test code for compressors and vacuum pumps - Engineering method (grade 2)
EN 60204-1: 2006	Safety of machinery - Electrical equipment of machines - Part 1: General requirements
EN 61000-6-2: 2005	Electromagnetic compatibility (EMC) - Generic immunity standards. Immunity for industrial environments
EN 61000-6-4: 2007 + A1: 2011	Electromagnetic compatibility (EMC) - Generic immunity standards. Emission standard for industrial environments
EN ISO 13849-1: 2015 ⁽¹⁾	Safety of machinery - Safety-related parts of control systems - Part 1: General principles for design
EN ISO 13463-1: 2009	Non-electrical equipment for potentially explosive atmospheres - Part 1: Basic methodology and requirements
EN ISO 1127-1: 2011	Explosive atmospheres - Explosion prevention and protection - Part 1: Basic concepts and methodology

<p>Manufacturer</p>  <p>Dr.-Ing. Karl Busch General Director</p>	<p>Person authorized to compile the technical file</p> <p>Andrej Riwe Technical writer</p>
--	--

Maulburg, 04.04.2016

Argentina

Busch Argentina S.R.L.
Santo Domingo 3076
C1293AGN-Capital Federal
Buenos Aires
Tel: +54 11 4302 8183
Fax: +54 11 4301 0896
e-mail: info@busch-vacuum.com.ar

Australia

Busch Australia Pty. Ltd.
30 Lakeside Drive
Broadmeadows, Vic. 3047
Tel: +61 3 93 55 06 00
Fax: +61 3 93 55 06 99
e-mail: sales@busch.com.au

Austria

Busch Austria GmbH
Industriepark Nord
2100 Korneuburg
Tel: +43 2262 / 756 65-0
Fax: +43 2262 / 756 65-20
e-mail: busch@busch.at

Belgium

Busch N.V. Kruinstraat 7
9160 Lokeren
Tel: +32 9 / 348 47 22
Fax: +32 9 / 348 65 35
e-mail: info@busch.be

Brazil

Busch do Brasil Ltda.
Rod. Edgard Máximo Zambotto, Km 64
13240-000 Jarinu-SP
Tel: +55 11-4016 1400/5277
Fax: +55 11-4016 5399
e-mail: vendas@buschdobrasil.com.br

Canada

Busch Vacuum Technics Inc.
1740, Lionel Bertrand
Boisbriand, Québec J7H 1N7
Tel: +1 450 435 6899
Fax: +1 450 430 5132
e-mail: info@busch.ca

Chile

Busch Chile S. A.
Calle El Roble N°375-G
Lampa - Santiago
Tel: +56 2 3765136
Fax: +56 2 7387092
e-mail: info@busch.cl

China

Busch Vacuum (Shanghai) Co., Ltd
No.5, Lane 195 Xipu Road
Songjiang Industrial Estate East New Zone
Shanghai 201611 PRC
Tel: +86 (0)21 67600800
Fax: +86 (0)21 67600700
e-mail: busch@busch-china.com

Czech Republic

Busch Vakuum s.r.o.
Pražákova 10
619 00 Brno-Horní Heršpice
Tel: +420 543 42 48 55
Fax: +420 543 42 48 56
e-mail: info@buschpumps.cz

Denmark

Busch Vakuumtechnik A/S Parallelvej
11
8680 Ry
Tel: +45 87 88 07 77
Fax: +45 87 88 07 88
e-mail: info@busch.dk

Finland

Busch Vakuumtechnik Oy
Sinikellontie 4
01300 Vantaa
Tel: +358 9 774 60 60
Fax: +358 9 774 60 666
e-mail: info@busch.fi

France

Busch France S.A.S.
16, Rue du Bois Chaland
91090 Lisses
Tel: +33 16989 8989
Fax: +33 16989 8958
e-mail: busch@busch.fr

Germany

Dr.-Ing. K. Busch GmbH
Schauinslandstr. 1
79689 Maulburg
Tel: +49 76 22 6 81-0
Fax: +49 76 22 6 81-194
e-mail: info@busch.de

Dr.-Ing. K. Busch GmbH
Niederlassung Nord
Ernst-Abbe-Str. 1-3
25451 Quickborn
Tel: +49 41 06 7 99 67-0
Fax: +49 41 06 7 99 67-77

Dr.-Ing. K. Busch GmbH
Niederlassung West
Nordring 35
64807 Dieburg
Tel: +49 60 71 92 82-0
Fax: +49 60 71 14 71

Dr.-Ing. K. Busch GmbH
Außenstelle Neuenrade
Breslauer Str. 36
58809 Neuenrade
Tel: +49 23 92 50 29 92
Fax: +49 23 92 50 72 11

Dr.-Ing. K. Busch GmbH
Niederlassung Süd-Ost
Gewerbstraße 3
90579 Langenzenn
Tel: +49 91 01 90 25-0
Fax: +49 91 01 90 25-25

Dr.-Ing. K. Busch GmbH
Außenstelle Zella-Mehlis
Am Rain 11
98544 Zella-Mehlis
Tel: +49 36 82 46 92 71
Fax: +49 36 82 46 92 73

Dr.-Ing. K. Busch GmbH
Außenstelle Meitingen-Ostendorf
Grüntenweg 8
86405 Meitingen-Ostendorf
Tel: +49 82 71 426-341
Fax: +49 82 71 426-342

Hungary

Busch Vacuum Kft.
Bentonit u. 8
1225 Budapest
Tel: +36 1 207 6135
Fax: +36 1 207 6136
e-mail: busch@busch-vacuum.hu

India

Busch Vacuum India Pvt Ltd.
Plot No. 110, Sector 7
PCNTDA, Bhosari
Pune 411026
Tel: +91 206410 2886
Fax: +91 202711 2838
e-mail: sales@buschindia.com

Ireland

Busch Ireland Ltd.
A10-11 Howth Junction Business Centre
Kilbarrack, Dublin 5
Tel: +353 1 832 1466
Fax: +353 1 832 1470
e-mail: sales@busch.ie

Israel

Busch Israel Ltd.
1 Mevo Sivan Street
Qiryat Gat 82022, Israel
Tel: +972 (0)8 6810485
Fax: +972 (0)8 6810486
e-mail: service_sales@busch.co.il

Italy

Busch Italia S.r.l.
Via Ettore Majorana, 16
20054 Nova Milanese
Tel: +39 0362 370 91
Fax: +39 0362 370 999
e-mail: info@busch.it

Japan

Nippon Busch K.K.
1-23-33, Megumigaoka
Hiratsuka City, Kanagawa
Japan 259-1220
Tel: +81 463-50-4000
Fax: +81 463-50-4004
e-mail: info@busch.co.jp

Korea

Busch Korea Ltd.
248-2, Ichi-ri, Majang-Myun,
Icheon-si, Kyunggi-Do
Tel: +82 31 321 8114
Fax: +82 31 321 8877
e-mail: busch@buschkorea.co.kr

Malaysia

Busch Malaysia Sdn Bhd.
4&6, Jalan Taboh 33/22, Seksyen 33
Shah Alam Technology Park
40400 Shah Alam
Selangor Darul Ehsan
Tel: +60 3 5122 2128
Fax: +60 3 5122 2108
e-mail: busch@busch.com.my

Mexico

Busch Vacuum Mexico S. de R.L. de C.V.
Tlaquepaque 4865, Los Altos
Monterrey, Nuevo Leon
Mexico 64370
Tel: +52 81 8311-1385
Fax: +52 81 8311-1386
e-mail: info@busch.com.mx

Netherlands

Busch B.V. Pompmolenlaan 2
3447 GK Woerden
Tel: +31 348-462300
Fax: +31 348-422939
e-mail: info@busch.nl

New Zealand

Busch New Zealand Ltd.
Unit D, 41 Arrenway Drive
Albany, Auckland 1330
Tel: +64 9 414 7782
Fax: +64 9 414 7783
e-mail: sales@busch.co.nz

Norway

Busch Vakuumteknikk AS
Hestehagen 2
1440 Drøbak
Tel: +47 64 98 98 50
Fax: +47 64 93 66 21
e-mail: busch@busch.no

Poland

Busch Polska Sp. z o.o.
Ul. Chopina 27
87-800 Włocławek
Tel: +48 54 2315400
Fax: +48 54 2327076
e-mail: busch@busch.com.pl

Portugal

Busch Ibérica S.A., Sucursal em Portugal
Zona Industrial Norte, Fração B, Armazém 2
3750-753 Raso de Travassô - Agueda
Aveiro, Portugal
Tel: +351 234 648 070
Fax: +351 234 648 068
e-mail: geral@buschib.pt

Russia

Busch Vacuum Russia OOO
Kotlyakovskaya str., 6/9
115201 Moscow
Tel: +7 495 6486726
Fax: +7 495 6486724
e-mail: info@busch.ru

Singapore

Busch Vacuum Singapore Pte Ltd
20 Shaw Road
Unit 01-03 Ching Shine Building
Singapore 367956
Tel: +65 6488 0866
Fax: +65 6288 0877
e-mail: busch@busch.com.sg

South Africa

Busch Vacuum South Africa (Pty) Ltd.
Denver
Johannesburg
Tel: +27 11 856 0650/6
Fax: +27 11 856 0625
e-mail: joe.jagger@busch.co.za

Spain

Busch Ibérica S.A.
Pol. Ind. Coll de la Manya
C/ Jaume Ferran, 6-8
08403 Granollers
Tel: +34 93 861 61 60
Fax: +34 93 840 91 56
e-mail: busch@buschib.es

Sweden

Busch Vakuumteknik AB
Bråta Industriområde
435 33 Mölnlycke
Tel: +46 31-338 00 80
Fax: +46 31-338 00 89
e-mail: info@busch.se

Switzerland

Busch AG Waldweg 22
4312 Magden
Tel: +41 61 / 845 90 90
Fax: +41 61 / 845 90 99
e-mail: info@buschag.ch

Taiwan

Busch Taiwan Corporation
1F. No. 69, Sec. 3, Beishen Road
Shenkeng Township,
Taipei County 222
Tel: +886 2 2662 0775
Fax: +886 2 2662 0796
e-mail: info@busch.com.tw

Thailand

Busch Vacuum (Thailand) Co., Ltd.
888/30 Moo19, Soi Yingcharoen,
Bangplee-Tamru Road,
Bangpleeyai, Bangplee,
Samutprakarn 10540
Tel: +66 2-382-5428
Fax: +66 2-382-5429
e-mail: info@busch.co.th

Turkey

VAKUTEK
Emlak Kredi Ishani No: 179
34672 Üsküdar-Istanbul
Tel: +90 216 310 0573
Fax: +90 216 343 5126
e-mail: vakutek@ttnet.net.tr

United Kingdom

Busch (UK) Ltd
Hortonwood 30
Telford Shropshire TF1 7YB
Tel: +44 1952 677 432
Fax: +44 1952 677 423
e-mail: sales@busch.co.uk

USA

Busch LLC
516-B Viking Drive
Virginia Beach, VA 23452
Tel: +1 757 463-7800
Fax: +1 757 463 7407
e-mail: marketing@buschusa.com