



Installation and Operating Instructions

O₂

Vacuum Pumps

Mink MM 1324, 1202, 1252, 1322, 1200, 1250, 1320 AV Oxygen



Busch Produktions GmbH
Schauinslandstr. 1
79689 Maulburg
Germany

Table of Contents

Preface	2
Product Description	3
Use	3
Principle of Operation	3
Cooling	4
Start Controls	4
Safety	4
Intended Use	4
Safety Notes	4
Noise Emission	4
Transport	4
Transport in Packaging	4
Transport without Packaging	4
Storage	5
Short-term Storage	5
Conservation	5
Installation and Commissioning	5
Installation Prerequisites	5
Mounting Position and Space	5
Suction Connection	6
Gas Discharge	6
Electrical Connection / Controls	6
Installation	6
Mounting	6
Checking Synchronising Gear Operating Fluid	6
Connecting Electrically	6
Connecting Lines/Pipes	7
Recording of Operational Parameters	7
Operation Notes	7
Use	7
Maintenance	8
Maintenance Schedule	8
Monthly:	9
Every 3 Months:	9
Every 6 Months:	9
Every Year:	9
Every 20000 Operating Hours, At the Latest after 6 Years:	9
Changing Synchronising Gear Operating Fluid	9
Overhaul	9
Removal from Service	9
Temporary Removal from Service	9
Recommissioning	9
Dismantling and Disposal	10
Troubleshooting	11
Spare Parts	14
Accessories	14
Operating Fluid	14
EC-Declaration of Conformity	15
Technical Data	16
Busch – All over the World in Industry	17

Preface

Congratulations on your purchase of the Busch vacuum pump. With watchful observation of the field's requirements, innovation and steady development Busch delivers modern vacuum and pressure solutions worldwide.

These operating instructions contain information for

- product description,
- safety,
- transport,
- storage,
- installation and commissioning,
- maintenance,
- overhaul,
- troubleshooting and
- spare parts

of the vacuum pump.

For the purpose of these instructions, "handling" the vacuum pump means the transport, storage, installation, commissioning, influence on operating conditions, maintenance, troubleshooting and overhaul of the vacuum pump.

Prior to handling the vacuum pump these operating instructions shall be read and understood. If anything remains to be clarified please contact your Busch representative!

Keep these operating instructions and, if applicable, other pertinent operating instructions available on site.

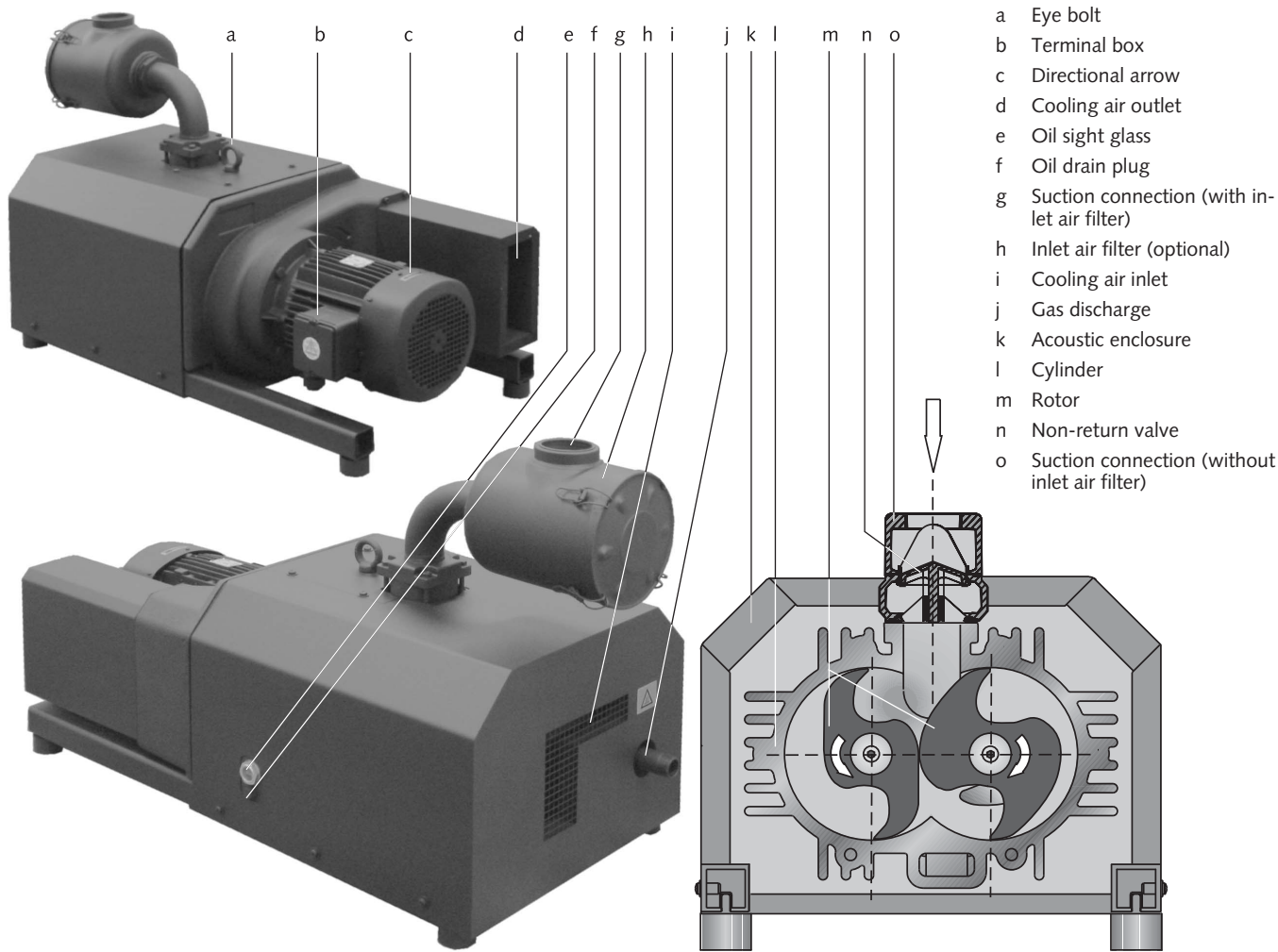

Product Description

Use

The vacuum pump is intended for

- the suction of
- air and other dry, non-aggressive, non-toxic and non-explosive gases with increased oxygen content (volume content greater than 21 percent)

Conveying media with a lower or higher density than air leads to an increased thermal and/or mechanical load on the vacuum pump and is permissible only after prior consultation with Busch.

Max. allowed temperature of the inlet gas: 40 °C

The gas shall be free from vapours that would condensate under the temperature and pressure conditions inside the vacuum pump.

The vacuum pump is intended for the placement in a non-potentially explosive environment.

Max. permissible number of startings per hour: 12

Vacuum pumps MM 1324 AV are thermally suitable for continuous operation down to ultimate pressure.

Vacuum pumps MM 1202 AV and MM 1252 AV Oxygen are thermally suitable for continuous operation at intake pressures down to 100 hPa abs (100 mbar abs). By means of process control and/or vacuum relief valves it must be made sure that the minimum allowed intake pressure will not be underrun. As a protection against overheating vacuum pumps MM 1202 AV and MM 1252 AV Oxygen are equipped with a safety valve. The safety valve is not designed for frequent use and must therefore not be used as a system pressure regulating valve.

Vacuum pumps MM 1322 AV Oxygen are thermally suitable for continuous operation at intake pressures down to 150 hPa abs (150 mbar abs). By means of process control and/or vacuum relief valves it must be made sure that the minimum allowed intake pressure will not be underrun. As a protection against overheating vacuum pumps MM 1322 AV Oxygen are equipped with a safety valve. The safety valve is not designed for frequent use and must therefore not be used as a system pressure regulating valve.



WARNING

Organic matter and oxygen constitute potentially explosive mixtures.

Risk of explosion!

No foreign matter is permitted inside the vacuum pump.

For the lubrication of the vacuum pump only special operating substances may be used, mineral or synthetic oil or grease must not be used!

Principle of Operation

The vacuum pump works on the claw principle.

The components are dimensioned such, that on the one hand there is never contact between the two claws or between a claw and the cylinder, on the other hand the gaps are small enough to keep the clearance loss between the chambers low.

In order to avoid the suction of solids, the vacuum pump is equipped with a screen (715) in the suction connection.

In order to avoid reverse rotation after switching off, the vacuum pump is equipped with a non-return valve (n).

The vacuum pump compresses the inlet gas absolutely oil-free. A lubrication of the pump chamber is neither necessary nor allowed.

Cooling

The vacuum pump is cooled by

- radiation of heat from the surface of the vacuum pump
- the air flow from the fan wheel of the drive motor
- the process gas
- the air flow from the fan wheel on the shaft of the vacuum pump

Start Controls

The vacuum pump comes without start controls. The control of the vacuum pump is to be provided in the course of installation.

Safety

Intended Use

Definition: For the purpose of these instructions, "handling" the vacuum pump means the transport, storage, installation, commissioning, influence on operating conditions, maintenance, troubleshooting and overhaul of the vacuum pump.

The vacuum pump is intended for industrial use. It shall be handled only by qualified personnel.

The allowed media and operational limits (→ page 3: Product Description) and the installation prerequisites (→ page 5: Installation Prerequisites) of the vacuum pump shall be observed both by the manufacturer of the machinery into which the vacuum pump is to be incorporated and by the operator.

The maintenance instructions shall be observed.

Prior to handling the vacuum pump these installation and operating instructions shall be read and understood. If anything remains to be clarified please contact your Busch representative!

Safety Notes

The vacuum pump has been designed and manufactured according to state-of-the-art methods. Nevertheless, residual risks may remain. These operating instructions highlight potential hazards where appropriate. Safety notes are tagged with one of the keywords DANGER, WARNING and CAUTION as follows:



DANGER

Disregard of this safety note will always lead to accidents with fatal or serious injuries.



WARNING

Disregard of this safety note may lead to accidents with fatal or serious injuries.



CAUTION

Disregard of this safety note may lead to accidents with minor injuries or property damage.

Noise Emission

For the sound pressure level in free field according to EN ISO 2151 → page 16: Technical Data.



CAUTION

The vacuum pump emits noise of high intensity in a narrow band.

Risk of damage to the hearing.

Persons staying in the vicinity of a non noise insulated vacuum pump over extended periods shall wear ear protection.

Transport

Transport in Packaging

Packed on a pallet the vacuum pump is to be transported with a forklift.

Transport without Packaging

In case the vacuum pump is packed in a cardboard box with inflated cushions:

- ◆ Remove the inflated cushions from the box

In case the vacuum pump is in a cardboard box cushioned with rolled corrugated cardboard:

- ◆ Remove the corrugated cardboard from the box

In case the vacuum pump is laid in foam:

- ◆ Remove the foam

In case the vacuum pump is bolted to a pallet or a base plate:

- ◆ Remove the bolting between the vacuum pump and the pallet/base plate

In case the vacuum pump is fastened to the pallet by means of tightening straps:

- ◆ Remove the tightening straps



CAUTION

Do not walk, stand or work under suspended loads.

- Make sure that the eyebolt (a) is in faultless condition (replace a damaged, e.g. bent eyebolt with a new one)
- Make sure that the eyebolt (a) is fully screwed in and tightened by hand
- Attach lifting gear securely to the eyebolt (a) on the synchronising gear

When the vacuum pump is equipped with a very heavy drive motor and would hang very inclined (>10 °) on the synchronising gear eyebolt alone:

- ◆ Attach lifting gear securely to the eyebolts on the synchronising gear (a) and on the drive motor

In case the drive motor comes without an eyebolt or the eyebolt on the drive motor is located at an unfavourable position:

- ◆ Loop a belt/rope with suitable length and strength around the flange of the drive motor
- Attach the lifting gear to a crane hook with safety latch
- Lift the vacuum pump with a crane

In case the vacuum pump was bolted to a pallet or a base plate:

- ◆ Remove the stud bolts from the rubber feet

Storage

Short-term Storage

- Make sure that the suction connection and the gas discharge are closed (leave the provided plugs in)
- Store the vacuum pump
 - if possible in original packaging,
 - indoors,
 - dry,
 - dust free and
 - vibration free

Conservation

In case of adverse ambient conditions (e.g. aggressive atmosphere, frequent temperature changes) conserve the vacuum pump immediately. In case of favourable ambient conditions conserve the vacuum pump if a storage of more than 3 months is scheduled.

- Make sure that all ports are firmly closed; seal all ports that are not sealed with PTFE-tape, gaskets or o-rings with adhesive tape

Note: VCI stands for "volatile corrosion inhibitor". VCI-products (film, paper, cardboard, foam) evaporate a substance that condenses in molecular thickness on the packed good and by its electro-chemical properties effectively suppresses corrosion on metallic surfaces. However, VCI-products may attack the surfaces of plastics and elastomers. Seek advice from your local packaging dealer! Busch uses CORTEC VCI 126 R film for the overseas packaging of large equipment.

- Wrap the vacuum pump in VCI film
- Store the vacuum pump
 - if possible in original packing,
 - indoors,
 - dry,
 - dust free and
 - vibration free.

For commissioning after conservation:

- Make sure that all remains of adhesive tape are removed from the ports
- Commission the vacuum pump as described in the chapter Installation and Commissioning (→ page 5)

Installation and Commissioning



WARNING

Installation and commissioning must only be performed by professionals who are informed about the applicable safety regulations and trained in the handling of oxygen.

The German accident prevention regulation Oxygen, BGR 500 chapter 2.32 (BGV B7) or the corresponding national accident prevention regulation resp. must be complied with unconditionally.

Installation Prerequisites



CAUTION

In case of non-compliance with the installation prerequisites, particularly in case of insufficient cooling:

Risk of damage or destruction of the vacuum pump and adjoining plant components!

Risk of injury!

The installation prerequisites must be complied with.

- Make sure that the integration of the vacuum pump is carried out such that the essential safety requirements of the Machine Directive 2006/42/EC are complied with (in the responsibility of the designer of the machinery into which the vacuum pump is to be incorporated; → page 15: note in the EC-Declaration of Conformity)

Mounting Position and Space

- Make sure that the environment of the vacuum pump is not potentially explosive
- Make sure that the following ambient conditions will be complied with:
 - ambient temperature: 0 ... 40 °C
 - ambient pressure: atmospheric
- Make sure that the environmental conditions comply with the protection class of the drive motor (according to the nameplate)
- Make sure that the vacuum pump can neither inadvertently nor intentionally be stepped on and cannot be used as a support for heavy objects
- Make sure that the vacuum pump cannot be hit by falling objects
- Make sure that the vacuum pump will be placed or mounted horizontally
- Make sure that the base for placement / mounting base is even
- Make sure that in order to warrant a sufficient cooling there will be a clearance of minimum 1 m between the vacuum pump and nearby walls
- Make sure that no heat sensitive parts (plastics, wood, cardboard, paper, electronics) will touch the surface of the vacuum pump



CAUTION

The vacuum pump is not absolutely gas tight.

Risk of explosion!

The installation space or location must be vented such that no impermissible accumulation of oxygen will occur.

- Make sure that the installation space or location is vented such that a sufficient cooling of the vacuum pump is warranted



CAUTION

During operation the surface of the vacuum pump may reach temperatures of more than 70 °C.

Risk of burns!

- Make sure that the vacuum pump will not be touched inadvertently during operation, provide a guard if appropriate
- Make sure that the sight glass (e, 76) of the synchronising gear will remain accessible

Suction Connection



WARNING

Any contamination of the vacuum pump with foreign material, particularly with organic material leads to imminent risk of explosion.

By means of suitable filters it must be made sure that no foreign material, particularly no organic material will find its way into the vacuum pump.



CAUTION

Intruding foreign objects or liquids can destroy the vacuum pump.

In case the inlet gas can contain dust or other foreign solid particles:

- ◆ Make sure that a suitable filter (5 micron or less) is installed upstream the vacuum pump
- ◆ Make sure that the filter is approved for oxygen applications
- Make sure that the suction line fits to the suction connection (o) of the vacuum pump
- Make sure that the gas will be sucked through a vacuum-tight flexible hose or a pipe

In case of using a pipe:

- ◆ Make sure that the pipe will cause no stress on the vacuum pump's connection, if necessary use an expansion joint
- Make sure that the line size of the suction line over the entire length is at least as large as the suction connection (o) of the vacuum pump

In case the length of the suction line exceeds 2 m it is prudent to use larger line sizes in order to avoid a loss of efficiency and an overload of the vacuum pump. Seek advice from your Busch representative!

In case the vacuum shall be maintained after shutdown of the vacuum pump:

- ◆ Provide a manual or automatic operated valve (= non-return valve) in the suction line
- Make sure that the suction line does not contain foreign objects, e.g. welding scales

Gas Discharge



CAUTION

Prior to starting up it must be made sure that the plug screws are removed from gas discharge.

Risk of damage to the vacuum pump!

The discharged gas must flow without obstruction. It is not permitted to shut off or throttle the discharge line or to use it as a pressurised air source.

The following guidelines for the discharge line do not apply, if the aspirated air is discharged to the environment right at the vacuum pump.

- Make sure that the discharge line fits to the gas discharge (j) of the vacuum pump

In case of using a pipe:

- ◆ Make sure that the pipe will cause no stress on the vacuum pump's connection, if necessary use an expansion joint
- Make sure that the line size of the discharge line over the entire length is at least 2"

In case the length of the discharge line exceeds 2 m it is prudent to use larger line sizes in order to avoid a loss of efficiency and an overload of the vacuum pump. Seek advice from your Busch representative!

- Make sure that the discharge line either slopes away from the vacuum pump or provide a liquid separator or a drip leg with a drain cock, so that no liquids can back up into the vacuum pump

Electrical Connection / Controls

- Make sure that the stipulations acc. to the EMC-Directive 2004/108/EC and Low-Voltage-Directive 2006/95/EC as well as the EN-standards, electrical and occupational safety directives and the local or national regulations, respectively, are complied with (this is the responsibility of the designer of the machinery into which the vacuum pump is to be incorporated; → page 15: note in the EC-Declaration of Conformity).
- Make sure that the power supply for the drive motor is compatible with the data on the nameplate of the drive motor
- Make sure that an overload protection according to EN 60204-1 is provided for the drive motor
- Make sure that the drive of the vacuum pump will not be affected by electric or electromagnetic disturbance from the mains; if necessary seek advice from the Busch service

In case of mobile installation:

- ◆ Provide the electrical connection with grommets that serve as strain-relief

Installation

Mounting

- Make sure that the installation prerequisites (→ page 5) are complied with
- Set down or mount the vacuum pump at its location

Checking Synchronising Gear Operating Fluid



WARNING

The synchronising gear of the vacuum pump must only be operated with a special operating fluid.

This operating fluid is absolutely inert and does not contribute to the generation of potentially explosive gas mixtures.

Any contamination with organic matter compromises the explosion safety of the operating fluid!

In order to protect the gear of the vacuum pump against inadvertent filling with improper fluids, various ports are equipped with lead seals.

Removal or placement of lead seals or work that require the removal of lead seals must only be carried out by specially authorised and trained personnel.

The vacuum pump is delivered with operating fluid filled synchronising gear.

The level shall be slightly above the middle of the sight glass (e, 76).

- Check on the sight glass (e, 76) that the proper amount of operating fluid is filled

Connecting Electrically



WARNING

Risk of electrical shock, risk of damage to equipment.

Electrical installation work must only be executed by qualified personnel that knows and observes the following regulations:

- IEC 364 or CENELEC HD 384 or DIN VDE 0100, respectively,
- IEC-Report 664 or DIN VDE 0110,
- BGV A2 (VBG 4) or corresponding national accident prevention regulation.



CAUTION

The connection schemes given below are typical. Depending on the specific order or for certain markets deviating connection schemes may apply.

Risk of damage to the drive motor!

The inside of the terminal box shall be checked for drive motor connection instructions/schemes.

- Electrically connect the drive motor
- Connect the protective earth conductor

Delta connection (low voltage):

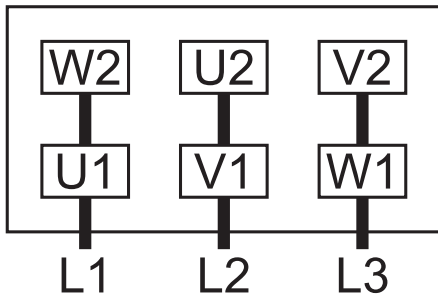

Star connection (high voltage):

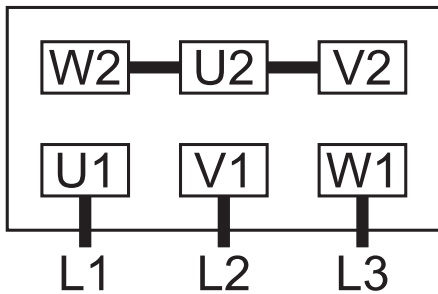

Double star connection, multi-voltage motor (low voltage):

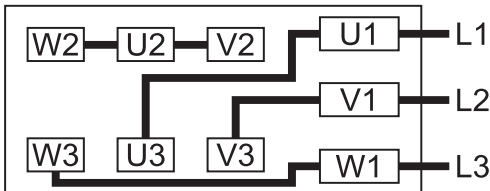

Star connection, multi-voltage motor (high voltage):

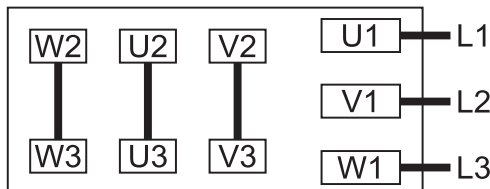

CAUTION

Operation in the wrong direction of rotation can destroy the vacuum pump in short time.

Risk of explosion!

Prior to starting-up it must be made sure that the vacuum pump is operated in the proper direction (clockwise rotating field).

- Determine the intended direction of rotation with the arrow (c) (stuck on or cast)
- "Bump" the drive motor
- Watch the fan wheel of the drive motor and determine the direction of rotation just before the fan wheel stops

If the rotation must be changed:

- ◆ Switch any two of the drive motor wires

Connecting Lines/Pipes

- Connect the suction line
- Connect the discharge line

Installation without discharge line:

- ◆ Make sure that the gas discharge (j) is open
- Make sure that all provided covers, guards, hoods etc. are mounted
- Make sure that cooling air inlets and outlets are not covered or obstructed and that the cooling air flow is not affected adversely in any other way
- Make sure that the lead seals are applied

Recording of Operational Parameters

As soon as the vacuum pump is operated under normal operating conditions:

- Measure the drive motor current and record it as reference for future maintenance and troubleshooting work

Operation Notes

Use



WARNING

The vacuum pump is designed for operation under the conditions described below.

In case of disregard risk of explosion!

The vacuum pump must only be operated under the conditions described below.



WARNING

Operating a faulty vacuum pump puts the explosion safety at risk.

Risk of explosion!

The vacuum pump must only be operated in faultless condition. A faulty vacuum pump must immediately be removed from service.

The vacuum pump is intended for

- the suction of
- air and other dry, non-aggressive, non-toxic and non-explosive gases with increased oxygen content (volume content greater than 21 percent)

Conveying media with a lower or higher density than air leads to an increased thermal and/or mechanical load on the vacuum pump and is permissible only after prior consultation with Busch.

Max. allowed temperature of the inlet gas: 40 °C

The gas shall be free from vapours that would condensate under the temperature and pressure conditions inside the vacuum pump.

The vacuum pump is intended for the placement in a non-potentially explosive environment.

Max. permissible number of startings per hour: 12

Vacuum pumps MM 1324 AV are thermally suitable for continuous operation down to ultimate pressure.

Vacuum pumps MM 1202 AV and MM 1252 AV Oxygen are thermally suitable for continuous operation at intake pressures down to 100 hPa abs (100 mbar abs). By means of process control and/or vacuum relief valves it must be made sure that the minimum allowed intake pressure will not be underrun. As a protection against overheating vacuum pumps MM 1202 AV and MM 1252 AV Oxygen are equipped with a safety valve. The safety valve is not designed for frequent use and must therefore not be used as a system pressure regulating valve.

Vacuum pumps MM 1322 AV Oxygen are thermally suitable for continuous operation at intake pressures down to 150 hPa abs (150 mbar abs). By means of process control and/or vacuum relief valves it must be made sure that the minimum allowed intake pressure will not be underrun. As a protection against overheating vacuum pumps MM 1322 AV Oxygen are equipped with a safety valve. The safety valve is not designed for frequent use and must therefore not be used as a system pressure regulating valve.



WARNING

Organic matter and oxygen constitute potentially explosive mixtures.

Risk of explosion!

No foreign matter is permitted inside the vacuum pump.

For the lubrication of the vacuum pump only special operating substances may be used, mineral or synthetic oil or grease must not be used!



CAUTION

During operation the surface of the vacuum pump may reach temperatures of more than 70 °C.

Risk of burns!

The vacuum pump shall be protected against contact during operation, it shall cool down prior to a required contact or heat protection gloves shall be worn.



CAUTION

The vacuum pump emits noise of high intensity in a narrow band.

Risk of damage to the hearing.

Persons staying in the vicinity of a non noise insulated vacuum pump over extended periods shall wear ear protection.

- Make sure that all provided covers, guards, hoods etc. remain mounted
- Make sure that protective devices will not be disabled
- Make sure that cooling air inlets and outlets will not be covered or obstructed and that the cooling air flow will not be affected adversely in any other way
- Make sure that the installation prerequisites (→ page 5: Installation Prerequisites) are complied with and will remain complied with, particularly that a sufficient cooling will be ensured

Maintenance



WARNING

The approval of the vacuum pump for the conveyance of gases with increased oxygen content remains valid only if the maintenance is conducted regularly according to the maintenance schedule below and genuine spare parts and consumables, approved for oxygen applications by Busch, are used exclusively.

Maintenance work must only be executed by qualified personnel that is trained in the handling of oxygen, informed about the relevant safety regulations and instructed in the handling of oxygen vacuum pumps by Busch.

The German accident prevention regulation Oxygen, BGR 500 chapter 2.32 (BGV B7) or the corresponding national accident prevention regulation resp. must be complied with unconditionally.



WARNING

The operating fluid is inert and does not contribute to the generation of potentially explosive gas mixtures.

Any contamination with organic matter compromises the explosion safety of the operating fluid!

In order to protect the gear of the vacuum pump against inadvertent filling with improper fluids, one or more ports are equipped with lead seals.

Removal or placement of lead seals or work that require the removal of lead seals must only be carried out by specially authorised and trained personnel.



DANGER

In case the vacuum pump conveyed gas that was contaminated with foreign materials which are dangerous to health, harmful material can reside in filters.

Danger to health during inspection, cleaning or replacement of filters.

Danger to the environment.

Personal protective equipment must be worn during the handling of contaminated filters.

Contaminated filters are special waste and must be disposed of separately in compliance with applicable regulations.



CAUTION

During operation the surface of the vacuum pump may reach temperatures of more than 70 °C.

Risk of burns!

- Prior to disconnecting connections make sure that the connected pipes/lines are vented to atmospheric pressure

Maintenance Schedule

Note: The maintenance intervals depend very much on the individual operating conditions. The intervals given below are upper limits that must not be exceeded.

Particularly heavy duty operation, such like high dust loads in the environment or in the process gas, other contaminations or ingress of process material, can make it necessary to shorten the maintenance intervals significantly.

Monthly:

- Make sure that the vacuum pump is shut down and locked against inadvertent start up

In case an inlet air filter (h) is installed:

- ◆ Check the inlet air filter (h), if necessary replace

In case of operation in a dusty environment:

- ◆ Clean as described under → page 9: Every 6 Months:

Every 3 Months:

- Make sure that the vacuum pump is shut down
- Check the level of the synchronising gear operating fluid

The level shall be slightly above the middle of the sight glass (e, 76).

The level of the synchronising gear should stay constant. If the level does fall, the gear is leaky and the vacuum pump requires repair (Busch service).

Every 6 Months:

- Make sure that the housing is free from dust and dirt, clean if necessary
- Make sure that the vacuum pump is shut down and locked against inadvertent start up
- Remove the acoustic enclosure
- Clean the fan cowlings, fan wheels, the ventilation grilles and cooling fins
- Mount the acoustic enclosure

Every Year:

- Make sure that the vacuum pump is shut down and locked against inadvertent start up

In case an inlet air filter (h) is installed:

- ◆ Replace the inlet air filter (h)
- Check the inlet screen (715), clean if necessary

Every 20000 Operating Hours, At the Latest after 6 Years:

- Change the synchronising gear operating fluid

Changing Synchronising Gear Operating Fluid

- Make sure that the vacuum pump is shut down and locked against inadvertent start up

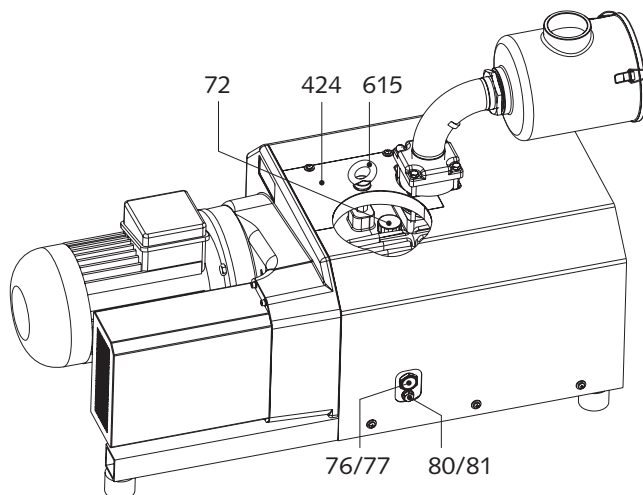

- Remove the eyebolt (a)
- Remove the lid (424)
- Undo the venting valve (72) for venting
- Place a drain tray underneath the drain plug (f, 80)

- Open the drain plug (f, 80) and drain the operating fluid
- Make sure that the seal ring (81) on the drain plug (f, 80) is serviceable, replace if necessary
- Firmly reinsert the drain plug (f, 80) together with the seal ring (81)
- Remove the venting valve (72) completely
- Fill in new operating fluid until the level is slightly above the middle of the sight glass (e, 76)
- Make sure that the seal ring on the venting valve (72) is undamaged, if necessary replace the venting valve (72)
- Firmly reinsert the venting valve (72) together with the seal ring
- Mount the lid (424)
- Reinsert the eyebolt (a)
- Reapply lead seals to the ports
- Dispose of the used operating fluid in compliance with applicable regulations

Overhaul



Improper work on the vacuum pump puts the operating safety at risk.

Risk of explosion!

Approval for operation will be void!

Any dismantling of the vacuum pump that is beyond of what is described in this manual must be done by specially trained Busch service personnel only.



In case the vacuum pump conveyed gas that was contaminated with foreign materials which are dangerous to health, harmful material can reside in pores, gaps and internal spaces of the vacuum pump.

Danger to health during dismantling of the vacuum pump.

Danger to the environment.

Prior to shipping the vacuum pump shall be decontaminated as good as possible and the contamination status shall be stated in a "Declaration of Contamination" (form downloadable from www.busch-vacuum.com).

Busch service will only accept vacuum pumps that come with a completely filled in and legally binding signed "Declaration of Contamination" (form downloadable from www.busch-vacuum.com).

Removal from Service

Temporary Removal from Service

- Prior to disconnecting pipes/lines make sure that all pipes/lines are vented to atmospheric pressure

Recommissioning

- Observe the chapter Installation and Commissioning (→ page 5)

Dismantling and Disposal



In case the vacuum pump conveyed gas that was contaminated with foreign materials which are dangerous to health, harmful material can reside in pores, gaps and internal spaces of the vacuum pump.

Danger to health during dismantling of the vacuum pump.

Danger to the environment.

During dismantling of the vacuum pump personal protective equipment must be worn.

The vacuum pump must be decontaminated prior to disposal.

- Drain the operating fluid
- Make sure that materials and components to be treated as special waste have been separated from the vacuum pump
- Make sure that the vacuum pump is not contaminated with harmful foreign material

According to the best knowledge at the time of printing of this manual the materials used for the manufacture of the vacuum pump involve no risk.

- Dispose of the used operating fluid in compliance with applicable regulations
- Dispose of the vacuum pump as scrap metal

Troubleshooting



WARNING

Risk of electrical shock, risk of damage to equipment.

Electrical installation work must only be executed by qualified personnel that knows and observes the following regulations:

- IEC 364 or CENELEC HD 384 or DIN VDE 0100, respectively,
- IEC-Report 664 or DIN VDE 0110,
- BGV A2 (VGB 4) or equivalent national accident prevention regulation.



CAUTION

During operation the surface of the vacuum pump may reach temperatures of more than 70 °C.

Risk of burns!

Let the vacuum pump cool down prior to a required contact or wear heat protection gloves.

Problem	Possible Cause	Remedy
The vacuum pump does not reach the usual pressure The drive motor draws a too high current (compare with initial value after commissioning) Evacuation of the system takes too long	The vacuum system or suction line is not leak-tight	Check the hose or pipe connections for possible leak
	The screen (715) in the suction connection (o) is partially clogged	Clean the screen (715) If cleaning is required too frequently install a filter upstream
	In case a filter (h) is installed on the suction connection (o): The filter (h) on the suction connection (o) is partially clogged	Clean or replace the inlet air filter (h), respectively
	Partial clogging in the suction, discharge or pressure line	Remove the clogging
	Long suction, discharge or pressure line with too small diameter	Use larger diameter
	The valve disk of the inlet non-return valve is stuck in closed or partially open position	Disassemble the inlet, clean the screen (715) and the valve (n) as required and reassemble
	Internal parts are worn or damaged	Repair the vacuum pump (Busch service)
The gas conveyed by the vacuum pump smells displeasing	Process components evaporating under vacuum	Check the process, if applicable
The vacuum pump does not start	The drive motor is not supplied with the correct voltage or is overloaded	Supply the drive motor with the correct voltage
	The drive motor starter overload protection is too small or trip level is too low	Compare the trip level of the drive motor starter overload protection with the data on the nameplate, correct if necessary In case of high ambient temperature: set the trip level of the drive motor starter overload protection 5 percent above the nominal drive motor current
	One of the fuses has blown	Check the fuses
	The connection cable is too small or too long causing a voltage drop at the vacuum pump	Use sufficiently dimensioned cable

	The vacuum pump or the drive motor is blocked	<p>Make sure the drive motor is disconnected from the power supply</p> <p>Remove the fan cover</p> <p>Try to turn the drive motor with the vacuum pump by hand</p> <p>If the vacuum pump is blocked:</p> <p>Repair the vacuum pump (Busch service)</p>
	The drive motor is defective	<p>Replace the drive motor (Busch service)</p> <p>(the proper function of the fan wheel requires the precise adjustment of the coupling on the motor shaft and on the pump shaft; therefore the motor can be mounted by the Busch service only)</p>
The vacuum pump is blocked	Solid foreign matter has entered the vacuum pump	<p>Repair the vacuum pump (Busch service)</p> <p>Make sure the suction line is equipped with a screen</p> <p>If necessary additionally provide a filter</p>
	Corrosion in the vacuum pump from remaining condensate	<p>Repair the vacuum pump (Busch service)</p> <p>Check the process</p>
	The vacuum pump was run in the wrong direction	<p>Repair the vacuum pump (Busch service)</p> <p>When connecting the vacuum pump make sure the vacuum pump will run in the correct direction (→ page 6: Installation)</p>
The drive motor is running, but the vacuum pump stands still	The coupling between the drive motor and the vacuum pump is defective	<p>Replace the coupling element</p> <p>(the proper function of the fan wheel requires the precise adjustment of the coupling on the motor shaft and on the pump shaft; therefore the coupling element can be replaced by the Busch service only)</p>
The vacuum pump starts, but labours or runs noisily or rattles The drive motor draws a too high current (compare with initial value after commissioning)	Loose connection(s) in the drive motor terminal box Not all drive motor coils are properly connected The drive motor operates on two phases only	<p>Check the proper connection of the wires against the connection diagram (particularly on motors with six coils)</p> <p>Tighten or replace loose connections</p>
	The vacuum pump runs in the wrong direction	Verification and rectification → page 5: Installation and Commissioning
	Foreign objects in the vacuum pump Stuck bearings	Repair the vacuum pump (Busch service)
The vacuum pump runs very noisily	Defective bearings	Repair the vacuum pump (Busch service)
	Worn coupling element	Replace the coupling element
	Low operating fluid level in the synchronising gear	Top up operating fluid
	Synchronising gear damaged due to operation with low operating fluid level	Repair the vacuum pump (Busch service)
The vacuum pump runs very hot	Insufficient air ventilation	<p>Make sure that the cooling of the vacuum pump is not impeded by dust/dirt</p> <p>Clean the fan cowlings, the fan wheels, the ventilation grilles and the cooling fins</p> <p>Install the vacuum pump in a narrow space only if sufficient ventilation is ensured</p>
	Ambient temperature too high	Observe the permitted ambient temperatures
	Temperature of the inlet gas too high	Observe the permitted temperatures for the inlet gas
	Mains frequency or voltage outside tolerance range	Provide a more stable power supply

Partial clogging of filters or screens Partial clogging in the suction, discharge or pressure line	Remove the clogging
Long suction, discharge or pressure line with too small diameter	Use larger diameter

Spare Parts

Note: When ordering spare parts or accessories acc. to the table below please always quote the type ("Type") and the serial no. ("No") of the vacuum pump. This will allow Busch service to check if the vacuum pump is compatible with a modified or improved part.

The approval of the vacuum pump for the conveyance of gases with increased oxygen content remains valid only if genuine spare parts and consumables, which are approved for oxygen applications by Busch, are used exclusively.

Your point of contact for service and spare parts in the United Kingdom:

Busch (UK) Ltd.
Hortonwood 30-35
Telford
Shropshire
TF1 7YB
Tel: 01952 677 432
Fax: 01952 677 423

Your point of contact for service and spare parts in Ireland:

Busch Ireland Ltd.
A10-11 Howth Junction Business Centre
Kilbarrack, Dublin 5
Tel: +353 (0)1 8321466
Fax: +353 (0)1 8321470

Your point of contact for service and spare parts in the USA:

Busch Inc.
516-B Viking Drive
Virginia Beach, VA 23452
Tel: 1-800-USA-PUMP (872-7867)

Your point of contact for service and spare parts in Canada:

Busch Vacuum Technics Inc.
1740, Boulevard Lionel Bertrand
Boisbriand (Montréal)
Québec J7H 1N7
Tel: 450 435 6899
Fax: 450 430 5132

Your point of contact for service and spare parts in Australia:

Busch Australia Pty. Ltd.
30 Lakeside Drive
Broadmeadows, Vic. 3047
Tel: (03) 93 55 06 00
Fax: (03) 93 55 06 99

Your point of contact for service and spare parts in New Zealand:

Busch New Zealand Ltd.
Unit D, Arrenway Drive
Albany, Auckland 1311
P O Box 302696
North Harbour, Auckland 1330
Tel: 0-9-414 7782
Fax: 0-9-414 7783

Find the list of Busch companies all over the world (by the time of the publication of these installation and operating instructions) on → page 17 (rear cover page).

Find the up-to-date list of Busch companies and agencies all over the world on the internet at www.busch-vacuum.com.

Pos.	Part	Qty	Part no.
72	Venting valve (=oil fill plug) with seal ring	1	0543 133 015
76	Sight glass	1	0583 000 001
77	Seal ring for sight glass	1	0480 000 271
80	Plug	1	0415 124 720
81	Seal ring for plug	1	0484 000 046
510	Coupling element	1	0512 135 985

715	Screen	1	0534 000 041
—	Filter cartridge, paper, for inlet filter (optional)	1	0532 000 004
—	Filter cartridge, polyester, for inlet filter (optional)	1	0532 121 864

Accessories

Accessories	Description	Part no.
Inlet air filter	inlet-side, horizontal, with paper cartridge, to separate solids	0945 000 071

Operating Fluid

Denomination	YLC 250 B
Base	PFPE
Density [g/cm ³]	1.9
Kinematic viscosity at 20 °C [mm ² /s]	270
Pourpoint [°C]	-35
Part no. 0.5 l packaging	0831 131 400
Part no. 1 l packaging	0831 108 878
Filling quantity, approx. [l]	1

EC-Declaration of Conformity

Note: This Declaration of Conformity and the **CE**-mark affixed to the nameplate are valid for the vacuum pump within the Busch-scope of delivery. When this vacuum pump is integrated into a superordinate machinery the manufacturer of the superordinate machinery (this can be the operating company, too) must conduct the conformity assessment process acc. to the Directive Machinery 2006/42/EC for the superordinate machine, issue the Declaration of Conformity for it and affix the **CE**-mark.

For maintenance of this Declaration of Conformity of vacuum pumps without a drive may only be used a drive with a written consent of Busch.

We

Busch Produktions GmbH
Schauinslandstr. 1
79689 Maulburg
Germany

declare that vacuum pumps **MM 1324, 1202, 1252, 1322, 1200, 1250, 1320 AV Oxygen**

in accordance with the European Directives:

- "Machinery" 2006/42/EC,
- "Electrical Equipment Designed for Use within Certain Voltage Limits" (so called "Low Voltage") 2006/95/EC,
- "Electromagnetic Compatibility" 2004/108/EC,

have been designed and manufactured to the following specifications:

Standard	Title of the Standard
Harmonised Standards	
EN ISO 12100-1 EN ISO 12100-2	Safety of machinery - Basic concepts, general principles of design - Part 1 and 2
EN ISO 13857	Safety of machinery - Safety distances to prevent hazard zones being reached by the upper and lower limbs
EN 1012-1 EN 1012-2	Compressors and vacuum pumps - Safety requirements - Part 1 and 2
EN ISO 2151	Acoustics - Noise test code for compressors and vacuum pumps - Engineering method (grade 2)
EN 60204-1	Safety of machinery - Electrical equipment of machines - Part 1: General requirements
EN 61000-6-1 EN 61000-6-2	Electromagnetic compatibility (EMC) - Generic immunity standards
EN 61000-6-3 EN 61000-6-4	Electromagnetic compatibility (EMC) - Generic emission standards

<p>Manufacturer</p>  <p>Dr.-Ing. Karl Busch General director</p>	<p>Person authorised to compile the technical file</p>  <p>Andrej Riwe Technical writer</p>
--	---

Technical Data

For motor connection parameters see nameplate

Type	Frequency [Hz]	Ultimate pressure [hPa abs = mbar abs]	Nominal motor rating [kW]	Nominal speed [min ⁻¹]	Nominal suction capacity [m ³ /h]	Sound pressure level (EN ISO 2151) at 400 hPa (=mbar) abs. suction pressure [db(A)]	Weight [kg]	Ambient temperature range [°C]	Ambient pressure	Synchronising gear operating fluid qty [l]	Synchronising gear operating fluid filled ex-works
MM 1324 AV	50	100	3.0	1500	160	72	~245 ... 260	0 ... 40	atmospheric	1	Busch YLC 250 B
	60		3.6	1800	192	76					
MM 1202 AV	50	100*	4.0	3000	200	77	~230				
	60		4.8	3600	240	81					
MM 1252 AV	50		4.5	3000	250	77	~240 ... 250				
	60		5.5	3600	300	81					
MM 1322 AV	50		5.5	3000	300	79	~260 ... 285				
	60		6.5	3600	360	84					
MM 1200 AV	50/60	150*	5.5	600-3600	max. 240	81	~240				
MM 1250 AV					max. 300		~250				
MM 1320 AV					max. 360		~260				

*to be limited by means of process control and/or vacuum relief valves

Australia

Busch Australia Pty. Ltd.
30 Lakeside Drive
Broadmeadows, Vic. 3047
Tel: (03) 93 55 06 00
Fax: (03) 93 55 06 99

Austria

Busch Austria GmbH
Industriepark Nord
2100 Korneuburg
Tel: 02262 / 756 65-0
Fax: 02262 / 756 65-20

Belgium

Busch N.V./Busch SA
Kruinstraat 7
9160 Lokeren
Tel: (0)9 / 348 47 22
Fax: (0)9 / 348 65 35

Brazil

Busch do Brasil Ltda.
Rod. Edgard Máximo Zambotto, Km 64
13240-000 Jarinu-SP
Tel: (55) 11-4016 1400/5277
Fax: (55) 11-4016 5399

Canada

Busch Vacuum Technics Inc.
1740, Boulevard Lionel Bertrand
Boisbriand (Montréal)
Québec J7H 1N7
Tel: 450 435 6899
Fax: 450 430 5132

Chile

Busch Chile S. A.
Calle El Roble N° 375-G
Lampa - Santiago
Tel: (56-2) 7387092
Fax: (56-2) 7387092

China

Busch Vacuum (Shanghai) Co., Ltd
No.5, Lane 195 Xipu Road
Songjiang Industrial Estate East New Zone
Shanghai 201611 PRC
Tel: +86 (0)21 67600800
Fax: +86 (0)21 67600700

Czech Republic

Busch Vakuu s.r.o.
Pražákova 10
619 00 Horní Heršpice
Brno
Tel: +420 543 42 48 55
Fax: +420 543 42 48 56

Denmark

Busch Vakuumteknik A/S
Parallevej 11
8680 Ry
Tel: +45 87 88 07 77
Fax: +45 87 88 07 88

Finland

Busch Vakuumteknik Oy
Sinikellontie 4
01300 VANTAA
Tel: 09 774 60 60
Fax: 09 774 60 666

France

Busch France S.A.
Parc Technologique
de Bois Chaland CE 2922
91029 Evry Cedex
Tel: 01 69 89 89 89
Fax: 01 60 86 16 74

Germany

Dr.-Ing. K. Busch GmbH
Schauinslandstr. 1
79689 Maulburg
Tel: (0 76 22) 6 81-0
Fax: (0 76 22) 6 81-194
e-mail: info@busch.de

Dr.-Ing. K. Busch GmbH
Niederlassung Nord
Ernst-Abbe-Str. 1-3
25451 Quickborn
Tel: (0 41 06) 7 99 67-0
Fax: (0 41 06) 7 99 67-77

Dr.-Ing. K. Busch GmbH
Niederlassung West
Nordring 35
64807 Dieburg
Tel: (0 60 71) 92 82-0
Fax: (0 60 71) 14 71

Dr.-Ing. K. Busch GmbH
Außenstelle Neuenrade
Breslauer Str. 36
58809 Neuenrade
Tel: (0 23 92) 50 29 92
Fax: (0 23 92) 50 72 11

Dr.-Ing. K. Busch GmbH
Niederlassung Süd-Ost
Gewerbestraße 3
90579 Langenzenn
Tel: (09 01) 90 25-0
Fax: (09 01) 90 25-25

Dr.-Ing. K. Busch GmbH
Außenstelle Zella-Mehlis
Am Rain 11
98544 Zella-Mehlis
Tel: (0 36 82) 46 92 71
Fax: (0 36 82) 46 92 73

Dr.-Ing. K. Busch GmbH
Außenstelle Meitingen-Ostendorf
Grüntenberg 8
86405 Meitingen-Ostendorf
Tel: (0 82 71) 426-341
Fax: (0 82 71) 426-342

India

Busch Vacuum India Pvt Ltd.
Plot No. 110, Sector 7
PCNTDA, Bhosari
Pune 411026, Maharashtra
Tel: (0)206410 2886
Fax: (0)202711 2838

Ireland

Busch Ireland Ltd.
A10-11 Howth Junction Business Centre
Kilbarrack, Dublin 5
Tel: 00353 1 832 1466
Fax: 00353 1 832 1470

Israel

Busch Israel Ltd.
1 Mevo Sivan Street
Qiryat Gat 82022, Israel
Tel: +972 (0)8 6810485
Fax: +972 (0)8 6810486

Italy

Busch Italia S.r.l.
Via Ettore Majorana, 16
20054 Nova Milanese
Tel: 0362 370 91
Fax: 0362 370 999

Japan

Nippon Busch K.K.
1-23-33, Megumigaoka
Hiratsuka City, Kanagawa
Japan 259-1220
Tel: 0463-50-4000
Fax: 0463-50-4004

Korea

Busch Korea Ltd.
392-1 Yangji-Ri, Yangji-Myun,
Yongin-si, Kyunggi-Do
Tel: (031) 321-8114
Fax: (031) 321 4330

Malaysia

Busch (Malaysia) Sdn Bhd.
6 Jalan Taboh 33/22
Shah Alam Technology Park
Section 33
40400 Shah Alam
Selangor D. E.
Tel: 03 5122 2128
Fax: 03 5122 2108

Mexico

Busch Vacuum Mexico S de RL de CV
Tlaquepaque 4865, Los Altos
Monterrey, Nuevo Leon
Mexico 64370
Tel: (81) 8311-1385
Fax: (81) 8311-1386

Netherlands

Busch B.V.
Pompvlietlaan 2
3447 GK Woerden
Postbus 2091
3440 DB Woerden
Tel: (0)348 - 462300
Fax: (0)348 - 422939

New Zealand

Busch New Zealand Ltd.
Unit D, 41 Arrenway Drive
Albany 0632
Auckland
Tel: 09 414 7782
Fax: 09 414 7783

Norway

Busch Vakuumteknikk AS
Hestehagen 2
1440 Drøbak
Tel: 64 98 98 50
Fax: 64 93 66 21

Poland

Busch Polska Sp. z o.o.
Ul. Chopina 27
87800 Włocławek
Tel: (054) 2315400
Fax: (054) 2327076

Portugal

Busch Ibérica S.A., Sucursal em Portugal
Zona Industrial Raso de Travassô, Fracção B, Armazém 2
3750-753 Agueda
Aveiro, Portugal
Tel: +351 234 648 070
Fax: +351 234 648 068

Russia

Busch Vacuum Russia OOO
Kotlyakovskaya str., 6/9
115201 Moscow
Tel: +7 495 6486726
Fax: +7 495 6486724

Singapore

Busch Vacuum Singapore Pte Ltd
20 Shaw Road
#01-03 Ching Shine Building
Singapore 36 79 56
Tel: (65) 6488 0866
Fax: (65) 6288 0877

Spain

Busch Ibérica S.A.
C/ Jaume Ferran, 6-8
Pol. Ind. Coll de la Manyà
08403 Granollers
Tel: +34 93 861 61 60
Fax: +34 93 840 91 56

Sweden

Busch Vakuumteknik AB
Bråta Industriområde
435 33 Mölnlycke
Tel: 031 - 338 00 80
Fax: 031 - 338 00 89

Switzerland

Busch AG
Waldweg 22
4312 Magden
Tel: 061 / 845 90 90
Fax: 061 / 845 90 99

Taiwan

Busch Taiwan Corporation
1F. No. 69, Sec. 3, Beishen Rd.
Shenkeng Township,
Taipei Country,
Taiwan (222), R.O.C
Tel: (02) 2662 0775
Fax: (02) 2662 0796

Thailand

Busch Vacuum (Thailand) Co., Ltd.
888/30 Moo19, Soi Yingcharoen, Bangplee-Tamru Rd.,
Bangpleeyai, Bangplee, Samutprakarn 10540 Thailand
Tel: (66) 2-382-5428
Fax: (66) 2-382-5429

Turkey

VAKUTEK
Emlak Kredi Ishani No: 179
81130 Üsküdar-Istanbul
Tel: (216) 310 0573
Fax: (216) 343 5126

United Kingdom

Busch (UK) Ltd
Hortonwood 30-35
Telford Shropshire TF1 7YB
Tel: 01952 677 432
Fax: 01952 677 423

USA

Busch, Inc.
516-B Viking Drive
Virginia Beach, VA 23452
Tel: (757) 463-7800
Fax: (757) 463 7407

Semiconductor Vacuum Group Inc.
Morgan Hill, CA 95037
Tel: (408) 955 1900
Fax: (408) 955 0229