

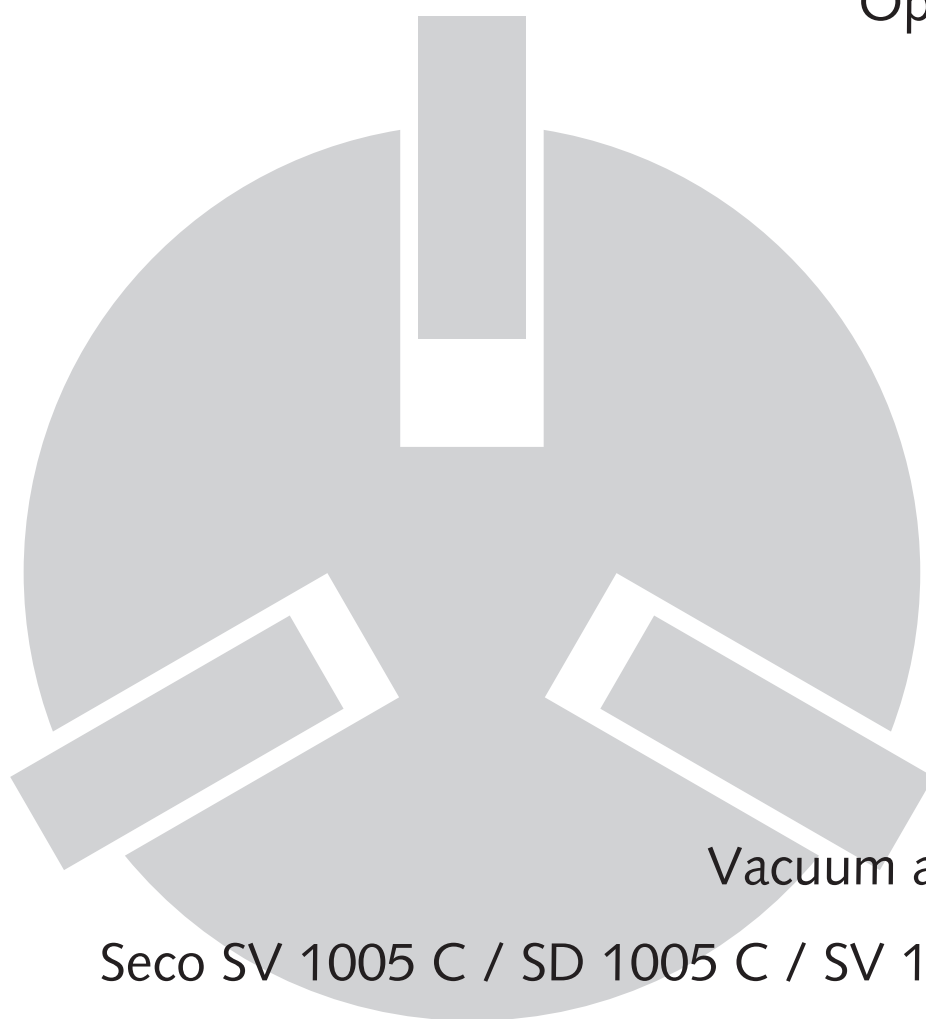

## Installation and Operating Instructions



Vacuum and Pressure Pumps

Seco SV 1005 C / SD 1005 C / SV 1008 C / SD 1008 C



Busch Vyroba CZ s.r.o.  
Svárovská 620,  
CZ 460 01, Liberec 11  
Czech Republic

# Table of Contents

<b>Preface</b> . . . . .	<b>2</b>
<b>Product Description</b> . . . . .	<b>3</b>
Use . . . . .	3
Principle of Operation . . . . .	3
Cooling . . . . .	3
Start Controls . . . . .	3
<b>Safety</b> . . . . .	<b>3</b>
Intended Use . . . . .	3
Safety Notes . . . . .	3
Noise Emission . . . . .	4
<b>Transport</b> . . . . .	<b>4</b>
Transport in Packaging . . . . .	4
Transport without Packaging . . . . .	4
<b>Storage</b> . . . . .	<b>4</b>
Short-term Storage . . . . .	4
Conservation . . . . .	4
<b>Installation and Commissioning</b> . . . . .	<b>4</b>
Installation Prerequisites . . . . .	4
Mounting Position and Space . . . . .	4
Suction Connection/Gas Inlet . . . . .	5
Gas Discharge . . . . .	5
Pressure Connection (SD 1005 C / SD 1008 C) . . . . .	5
Electrical Connection / Controls . . . . .	5
Installation . . . . .	5
Mounting . . . . .	5
Connecting Electrically . . . . .	6
Connecting Lines/Pipes . . . . .	6
Recording of Operational Parameters . . . . .	6
Operation Notes . . . . .	6
Use . . . . .	6
<b>Maintenance</b> . . . . .	<b>7</b>
Maintenance Schedule . . . . .	7
Monthly: . . . . .	7
Every 6 Months: . . . . .	7
Every Year: . . . . .	7
Every 1500 – 2000 (SD) / 2000 – 3000 (SV) Operating Hours: . . . . .	7
Check/Replacement of Vanes . . . . .	7
<b>Overhaul</b> . . . . .	<b>7</b>
<b>Removal from Service</b> . . . . .	<b>8</b>
Temporary Removal from Service . . . . .	8
Recommissioning . . . . .	8
Dismantling and Disposal . . . . .	8
<b>Troubleshooting</b> . . . . .	<b>9</b>
<b>Exploded View</b> . . . . .	<b>12</b>
<b>Spare Parts/Accessories</b> . . . . .	<b>13</b>
<b>EC-Declaration of Conformity</b> . . . . .	<b>14</b>
<b>Technical Data</b> . . . . .	<b>15</b>
<b>Busch – All over the World in Industry</b> . . . . .	<b>16</b>

# Preface

Congratulations on your purchase of the Busch vacuum and pressure pump. With watchful observation of the field's requirements, innovation and steady development Busch delivers modern vacuum and pressure solutions worldwide.

These operating instructions contain information for

- product description,
- safety,
- transport,
- storage,
- installation and commissioning,
- maintenance,
- overhaul,
- troubleshooting and
- spare parts

of the vacuum and pressure pump.

For the purpose of these instructions, "handling" the vacuum and pressure pump means the transport, storage, installation, commissioning, influence on operating conditions, maintenance, troubleshooting and overhaul of the vacuum and pressure pump.

**Prior to handling the vacuum and pressure pump these operating instructions shall be read and understood. If anything remains to be clarified please contact your Busch representative!**

**Keep these operating instructions and, if applicable, other pertinent operating instructions available on site.**

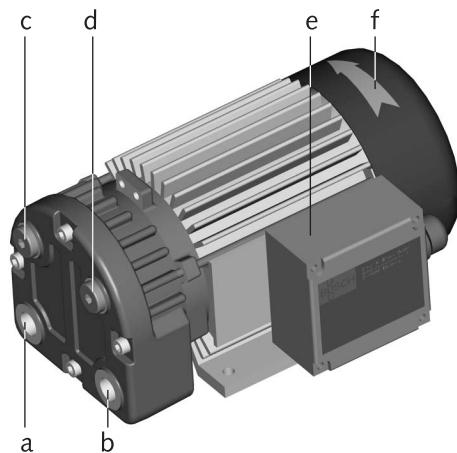

- a Suction connection/ gas inlet
- b Gas discharge/ pressure connection
- c Accessory connection suction side
- d Accessory connection pressure side
- e Terminal box
- f Directional arrow

## Product Description

### Use

The vacuum and pressure pump is intended for

- the suction (SV 1005 C / SV 1008 C)
- the compression (SD 1005 C / SD 1008 C)

of

- air and other dry, non-aggressive, non-toxic and non-explosive gases

Conveying media with a lower or higher density than air leads to an increased thermal and/or mechanical load on the vacuum and pressure pump and is permissible only after prior consultation with Busch.

The gas shall be free from vapours that would condensate under the temperature and pressure conditions inside the vacuum and pressure pump.

The vacuum and pressure pump is intended for the placement in a non-potentially explosive environment.

The vacuum and pressure pump is thermally suitable for continuous operation (100 percent duty).

Version with AC-motor: the drive is equipped with a thermal protection switch.

In case of vacuum operation (SV 1005 C / SV 1008 C):

The vacuum and pressure pump is ultimate pressure proof.

In case of pressure operation (SD 1005 C / SD 1008 C):

**The maximum allowed pressure on the pressure connection (b) is 2 bar abs (the nameplate of the vacuum and pressure pump indicates the valid pressure). By means of process control and/or pressure relief valves it must be made sure that the maximum allowed pressure will not be exceeded.**

### Principle of Operation

The vacuum and pressure pump works on the rotating vane principle.

A circular rotor is positioned centrally on the shaft of the vacuum and pressure pump (i.e. drive motor shaft).

The rotor rotates in an also circular, fixed cylinder, the centreline of which is offset from the centreline of the rotor such that the rotor and the inner wall of the cylinder almost touch along a line. Vanes (35), sliding in slots in the rotor, separate the space between the rotor and the cylinder into chambers. At any time gas is sucked in and at almost any time ejected. Therefore the vacuum and pressure pump works almost pulsation free.

The vacuum and pressure pump compresses the inlet gas absolutely oil-free. A lubrication of the pump chamber is neither necessary nor allowed.

### Cooling

The vacuum and pressure pump is cooled by

- radiation of heat from the surface of the vacuum and pressure pump
- the air flow from the fan wheel of the drive motor
- the process gas

### Start Controls

The vacuum and pressure pump comes without start controls. The control of the vacuum and pressure pump is to be provided in the course of installation.

## Safety

### Intended Use

**Definition:** For the purpose of these instructions, "handling" the vacuum and pressure pump means the transport, storage, installation, commissioning, influence on operating conditions, maintenance, troubleshooting and overhaul of the vacuum and pressure pump.

The vacuum and pressure pump is intended for industrial use. It shall be handled only by qualified personnel.

**The allowed media and operational limits (→ page 3: Product Description) and the installation prerequisites (→ page 4: Installation Prerequisites) of the vacuum and pressure pump shall be observed both by the manufacturer of the machinery into which the vacuum and pressure pump is to be incorporated and by the operator.**

The maintenance instructions shall be observed.

**Prior to handling the vacuum and pressure pump these installation and operating instructions shall be read and understood. If anything remains to be clarified please contact your Busch representative!**

### Safety Notes

The vacuum and pressure pump has been designed and manufactured according to state-of-the-art methods. Nevertheless, residual risks may remain. These operating instructions highlight potential hazards where appropriate. Safety notes are tagged with one of the keywords DANGER, WARNING and CAUTION as follows:



**DANGER**

**Disregard of this safety note will always lead to accidents with fatal or serious injuries.**



**WARNING**

**Disregard of this safety note may lead to accidents with fatal or serious injuries.**



## CAUTION

Disregard of this safety note may lead to accidents with minor injuries or property damage.

## Noise Emission

For the sound pressure level in free field according to EN ISO 2151  
→ page 15: Technical Data.

## Transport

### Transport in Packaging

Vacuum and pressure pumps individually packed in cardboard boxes can be carried by hand.

Packed on a pallet the vacuum and pressure pump is to be transported with a forklift.

### Transport without Packaging

In case the vacuum and pressure pump is packed in a cardboard box with inflated cushions:

- ◆ Remove the inflated cushions from the box

In case the vacuum and pressure pump is in a cardboard box cushioned with rolled corrugated cardboard:

- ◆ Remove the corrugated cardboard from the box

In case the vacuum and pressure pump is laid in foam:

- ◆ Remove the foam

Version without handle:

- ◆ Grasp the vacuum and pressure pump with both hands

Version with handle:

- ◆ Carry the vacuum and pressure pump using the handle

## Storage

### Short-term Storage

- Make sure that the suction connection/gas inlet and the gas discharge/pressure connection are closed (leave the provided plugs in)
- Store the vacuum and pressure pump
  - if possible in original packaging,
  - indoors,
  - dry,
  - dust free and
  - vibration free

### Conservation

In case of adverse ambient conditions (e.g. aggressive atmosphere, frequent temperature changes) conserve the vacuum and pressure pump immediately. In case of favourable ambient conditions conserve the vacuum and pressure pump if a storage of more than 3 months is scheduled.

- Make sure that all ports are firmly closed; seal all ports that are not sealed with PTFE-tape, gaskets or o-rings with adhesive tape

**Note:** VCI stands for "volatile corrosion inhibitor". VCI-products (film, paper, cardboard, foam) evaporate a substance that condenses in molecular thickness on the packed good and by its electro-chemical properties effectively suppresses corrosion on metallic surfaces. However, VCI-products may attack the surfaces of plastics and elastomers. Seek advice from your local packaging dealer! Busch uses CORTEC VCI 126 R film for the overseas packaging of large equipment.

- Wrap the vacuum and pressure pump in VCI film
- Store the vacuum and pressure pump
  - if possible in original packing,
  - indoors,
  - dry,
  - dust free and
  - vibration free.

For commissioning after conservation:

- Make sure that all remains of adhesive tape are removed from the ports
- Commission the vacuum and pressure pump as described in the chapter Installation and Commissioning (→ page 4)

## Installation and Commissioning

### Installation Prerequisites



## CAUTION

In case of non-compliance with the installation prerequisites, particularly in case of insufficient cooling:

Risk of damage or destruction of the vacuum and pressure pump and adjoining plant components!

Risk of injury!

The installation prerequisites must be complied with.

- Make sure that the integration of the vacuum and pressure pump is carried out such that the essential safety requirements of the Machine Directive 2006/42/EC are complied with (in the responsibility of the designer of the machinery into which the vacuum and pressure pump is to be incorporated; → page 14: note in the EC-Declaration of Conformity)

### Mounting Position and Space

- Make sure that the environment of the vacuum and pressure pump is not potentially explosive
- Make sure that the following ambient conditions will be complied with:
  - ambient temperature:  $-10 \dots +40 \text{ }^{\circ}\text{C}$
  - ambient pressure: atmospheric
- Make sure that the environmental conditions comply with the protection class of the drive motor (according to the nameplate)
- Make sure that the vacuum and pressure pump will be placed or mounted horizontally
- Make sure that the base for placement / mounting base is even
- Make sure that in order to warrant a sufficient cooling there will be a clearance of minimum 2 cm between the vacuum and pressure pump and nearby walls
- Make sure that no heat sensitive parts (plastics, wood, cardboard, paper, electronics) will touch the surface of the vacuum and pressure pump
- Make sure that the installation space or location is vented such that a sufficient cooling of the vacuum and pressure pump is warranted



#### CAUTION

During operation the surface of the vacuum and pressure pump may reach temperatures of more than 70 °C.

Risk of burns!

- Make sure that the vacuum and pressure pump will not be touched inadvertently during operation, provide a guard if appropriate

### Suction Connection/Gas Inlet



#### CAUTION

Intruding foreign objects or liquids can destroy the vacuum and pressure pump.

In case the inlet gas can contain dust or other foreign solid particles:

- ◆ Make sure that a suitable filter (5 micron or less) is installed upstream the vacuum and pressure pump

In case of compressor operation:

The following guidelines for the suction line do not apply, if the air to be compressed is taken in right at the vacuum and pressure pump.

- Make sure that the suction line fits to the suction connection/gas inlet (a) of the vacuum and pressure pump
- Make sure that the gas will be sucked through a vacuum-tight flexible hose or a pipe

In case of using a pipe:

- ◆ Make sure that the pipe will cause no stress on the vacuum and pressure pump's connection, if necessary use an expansion joint
- Make sure that the line size of the suction line over the entire length is at least as large as the suction connection/gas inlet (a) of the vacuum and pressure pump

In case of very long suction lines it is prudent to use larger line sizes in order to avoid a loss of efficiency. Seek advice from your Busch representative!

In case the vacuum shall be maintained after shutdown of the vacuum and pressure pump:

- ◆ Provide a manual or automatic operated valve (= non-return valve) in the suction line
- Make sure that the suction line does not contain foreign objects, e.g. welding scales

### Gas Discharge

In case of vacuum operation:

**The discharged gas must flow without obstruction. It is not permitted to shut off or throttle the discharge line or to use it as a pressurised air source.**

In case of vacuum operation:

The following guidelines for the discharge line do not apply, if the aspirated air is discharged to the environment right at the vacuum and pressure pump.

- Make sure that the discharge line fits to the gas discharge (b) of the vacuum and pressure pump

In case of using a pipe:

- ◆ Make sure that the pipe will cause no stress on the vacuum and pressure pump's connection, if necessary use an expansion joint
- Make sure that the line size of the discharge line over the entire length is at least as large as the gas discharge (b) of the vacuum and pressure pump

In case the length of the discharge line exceeds 0.5 m it is prudent to use larger line sizes in order to avoid a loss of efficiency and an overload of the vacuum and pressure pump. Seek advice from your Busch representative!

- Make sure that the discharge line either slopes away from the vacuum and pressure pump or provide a liquid separator or a drip leg with a drain cock, so that no liquids can back up into the vacuum and pressure pump

### Pressure Connection (SD 1005 C / SD 1008 C)

- Make sure that the pressure line fits to the pressure connection (b) of the vacuum and pressure pump
- Make sure that the pressure connection is connected to a pressure-tight flexible hose or a pipe
- Make sure that the pressure line is designed for 1.5 barg and 140 °C

In case of using a pipe:

- ◆ Make sure that the pipe will cause no stress on the vacuum and pressure pump's connection, if necessary use an expansion joint
- Make sure that the line size of the pressure line over the entire length is at least as large as the pressure connection (b) of the vacuum and pressure pump

In case the length of the pressure line exceeds 0.5 m it is prudent to use larger line sizes in order to avoid a loss of efficiency and an overload of the vacuum and pressure pump. Seek advice from your Busch representative!

- Make sure that the pressure line either slopes away from the vacuum and pressure pump or provide a liquid separator or a drip leg with a drain cock, so that no liquids can back up into the vacuum and pressure pump

### Electrical Connection / Controls

- Make sure that the stipulations acc. to the EMC-Directive 2004/108/EC and Low-Voltage-Directive 2006/95/EC as well as the EN-standards, electrical and occupational safety directives and the local or national regulations, respectively, are complied with (this is the responsibility of the designer of the machinery into which the vacuum and pressure pump is to be incorporated; → page 14: note in the EC-Declaration of Conformity).
- Make sure that the power supply matches the data on the nameplate of the vacuum and pressure pump
- Make sure that an overload protection according to EN 60204-1 is provided for the drive motor
- Make sure that the drive of the vacuum and pressure pump will not be affected by electric or electromagnetic disturbance from the mains; if necessary seek advice from the Busch service

In case of mobile installation:

- ◆ Provide the electrical connection with grommets that serve as strain-relief

### Installation

#### Mounting

- Make sure that the Installation Prerequisites (→ page 4) are complied with
- Set down or mount the vacuum and pressure pump at its location

## Connecting Electrically



WARNING

Risk of electrical shock, risk of damage to equipment.

Electrical installation work must only be executed by qualified personnel that knows and observes the following regulations:

- IEC 364 or CENELEC HD 384 or DIN VDE 0100, respectively,
- IEC-Report 664 or DIN VDE 0110,
- BGV A2 (VBG 4) or corresponding national accident prevention regulation.

- Observe the instructions/diagram for the drive motor connection from the motor terminal box
- Electrically connect the drive motor
- Connect the protective earth conductor



CAUTION

Operation in the wrong direction of rotation can destroy the vacuum and pressure pump in short time.

Prior to starting-up it must be made sure that the vacuum and pressure pump is operated in the proper direction.

Version with three-phase motor:

- ◆ Determine the intended direction of rotation with the arrow (f, 42) (stuck on or cast)
- ◆ "Bump" the drive motor
- ◆ Watch the fan wheel of the drive motor and determine the direction of rotation just before the fan wheel stops

If the rotation must be changed:

- ◆ Switch any two of the drive motor wires (three-phase motor)

## Connecting Lines/Pipes

- Connect the suction line

Installation without suction line:

- ◆ Make sure that the gas inlet (a) is open

- Connect the discharge line

or

- Connect the pressure line

Installation without discharge line:

- ◆ Make sure that the gas discharge (b) is open

- Make sure that all provided covers, guards, hoods etc. are mounted
- Make sure that cooling air inlets and outlets are not covered or obstructed and that the cooling air flow is not affected adversely in any other way

## Recording of Operational Parameters

As soon as the vacuum and pressure pump is operated under normal operating conditions:

- Measure the drive motor current and record it as reference for future maintenance and troubleshooting work

## Operation Notes

### Use



CAUTION

The vacuum and pressure pump is designed for operation under the conditions described below.

In case of disregard risk of damage or destruction of the vacuum and pressure pump and adjoining plant components!

Risk of injury!

The vacuum and pressure pump must only be operated under the conditions described below.

The vacuum and pressure pump is intended for

- the suction (SV 1005 C / SV 1008 C)
- the compression (SD 1005 C / SD 1008 C)

of

- air and other dry, non-aggressive, non-toxic and non-explosive gases

Conveying media with a lower or higher density than air leads to an increased thermal and/or mechanical load on the vacuum and pressure pump and is permissible only after prior consultation with Busch.

The gas shall be free from vapours that would condensate under the temperature and pressure conditions inside the vacuum and pressure pump.

The vacuum and pressure pump is intended for the placement in a non-potentially explosive environment.

The vacuum and pressure pump is thermally suitable for continuous operation (100 percent duty).

Version with AC-motor: the drive is equipped with a thermal protection switch.

In case of vacuum operation (SV 1005 C / SV 1008 C):

The vacuum and pressure pump is ultimate pressure proof.

In case of pressure operation (SD 1005 C / SD 1008 C):

**The maximum allowed pressure on the pressure connection (b) is 2 bar abs (the nameplate of the vacuum and pressure pump indicates the valid pressure). By means of process control and/or pressure relief valves it must be made sure that the maximum allowed pressure will not be exceeded.**



CAUTION

During operation the surface of the vacuum and pressure pump may reach temperatures of more than 70 °C.

Risk of burns!

The vacuum and pressure pump shall be protected against contact during operation, it shall cool down prior to a required contact or heat protection gloves shall be worn.

- Make sure that all provided covers, guards, hoods etc. remain mounted
- Make sure that protective devices will not be disabled
- Make sure that cooling air inlets and outlets will not be covered or obstructed and that the cooling air flow will not be affected adversely in any other way
- Make sure that the installation prerequisites (→ page 4: Installation Prerequisites) are complied with and will remain complied with, particularly that a sufficient cooling will be ensured

# Maintenance



**DANGER**

In case the vacuum and pressure pump conveyed gas that was contaminated with foreign materials which are dangerous to health, harmful material can reside in filters.

Danger to health during inspection, cleaning or replacement of filters.

Danger to the environment.

Personal protective equipment must be worn during the handling of contaminated filters.

Contaminated filters are special waste and must be disposed of separately in compliance with applicable regulations.



**CAUTION**

During operation the surface of the vacuum and pressure pump may reach temperatures of more than 70 °C.

Risk of burns!

- Prior to disconnecting connections make sure that the connected pipes/lines are vented to atmospheric pressure

## Maintenance Schedule

**Note:** The maintenance intervals depend very much on the individual operating conditions. The intervals given below shall be considered as starting values which should be shortened or extended as appropriate. Particularly heavy duty operation, such like high dust loads in the environment or in the process gas, other contaminations or ingress of process material, can make it necessary to shorten the maintenance intervals significantly.

### Monthly:

- Make sure that the vacuum and pressure pump is shut down and locked against inadvertent start up

In case an inlet air filter (62, 63) is installed:

- ◆ Check the inlet air filter (62, 63), if necessary replace

In case of operation in a dusty environment:

- ◆ Clean as described under → page 7: Every 6 Months:

### Every 6 Months:

- Make sure that the housing is free from dust and dirt, clean if necessary
- Make sure that the vacuum and pressure pump is shut down and locked against inadvertent start up
- Clean the fan cowl, the fan wheel, the ventilation grille and the cooling fins

### Every Year:

- Make sure that the vacuum and pressure pump is shut down and locked against inadvertent start up

In case an inlet air filter (62, 63) is installed:

- ◆ Replace the inlet air filter (62, 63)

In case an inlet screen is installed:

- ◆ Check the inlet screen, clean if necessary

### Every 1500 – 2000 (SD) / 2000 – 3000 (SV) Operating Hours:

- Replace the vanes (35) (→ page 7: Check/Replacement of Vanes)

# Check/Replacement of Vanes

- Make sure that the vacuum and pressure pump is shut down and locked against inadvertent start up
- Remove the cylinder cover

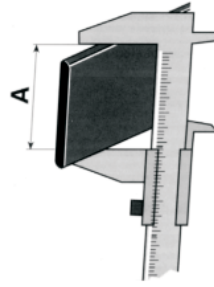

- Remove the vanes (35)
- Check the vanes (35) for damage
- Measure the height A of the vanes (35)



**CAUTION**

The vanes (35) are made of special carbon and are self-lubricating.

The vanes must by no means be lubricated with oil or grease.

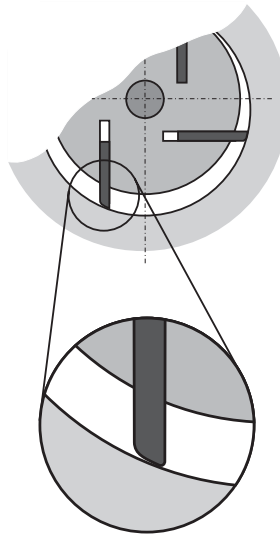

In case the vanes (35) are undamaged, the height A of all vanes is more than 23 mm and regular inspections in short intervals are ensured:

- ◆ Reinsert the vanes (35) as shown

In case a vane (35) is damaged, its height A is less than 23 mm, 1500 – 2000 (SD) / 2000 – 3000 (SV) operating hours have passed since the last change or will have passed until the next inspection:

- ◆ Insert new vanes (35) as shown

- Reattach the cylinder cover

# Overhaul



**CAUTION**

In order to achieve best efficiency and a long life the vacuum and pressure pump was assembled and adjusted with precisely defined tolerances.

This adjustment will be lost during dismantling of the vacuum and pressure pump.

It is therefore strictly recommended that any dismantling of the vacuum and pressure pump that is beyond of what is described in this manual shall be done by Busch service.



In case the vacuum and pressure pump conveyed gas that was contaminated with foreign materials which are dangerous to health, harmful material can reside in pores, gaps and internal spaces of the vacuum and pressure pump.

Danger to health during dismantling of the vacuum and pressure pump.

Danger to the environment.

Prior to shipping the vacuum and pressure pump shall be decontaminated as good as possible and the contamination status shall be stated in a "Declaration of Contamination" (form downloadable from [www.busch-vacuum.com](http://www.busch-vacuum.com)).

Busch service will only accept vacuum and pressure pumps that come with a completely filled in and legally binding signed "Declaration of Contamination" (form downloadable from [www.busch-vacuum.com](http://www.busch-vacuum.com)).

## Removal from Service

### Temporary Removal from Service

- Prior to disconnecting pipes/lines make sure that all pipes/lines are vented to atmospheric pressure

### Recommissioning

- Observe the chapter Installation and Commissioning (→ page 4)

### Dismantling and Disposal



In case the vacuum and pressure pump conveyed gas that was contaminated with foreign materials which are dangerous to health, harmful material can reside in pores, gaps and internal spaces of the vacuum and pressure pump.

Danger to health during dismantling of the vacuum and pressure pump.

Danger to the environment.

During dismantling of the vacuum and pressure pump personal protective equipment must be worn.

The vacuum and pressure pump must be decontaminated prior to disposal.

- Make sure that materials and components to be treated as special waste have been separated from the vacuum and pressure pump
- Make sure that the vacuum and pressure pump is not contaminated with harmful foreign material

According to the best knowledge at the time of printing of this manual the materials used for the manufacture of the vacuum and pressure pump involve no risk.

- Dispose of the vacuum and pressure pump as scrap metal



# Troubleshooting



## WARNING

Risk of electrical shock, risk of damage to equipment.

Electrical installation work must only be executed by qualified personnel that knows and observes the following regulations:

- IEC 364 or CENELEC HD 384 or DIN VDE 0100, respectively,
- IEC-Report 664 or DIN VDE 0110,
- BGV A2 (VBG 4) or equivalent national accident prevention regulation.



## CAUTION

During operation the surface of the vacuum and pressure pump may reach temperatures of more than 70 °C.

Risk of burns!

Let the vacuum and pressure pump cool down prior to a required contact or wear heat protection gloves.

Problem	Possible Cause	Remedy
<p>The vacuum and pressure pump does not reach the usual pressure</p> <p>The drive motor draws a too high current (compare with initial value after commissioning)</p> <p>Vacuum operation:</p> <p>Evacuation of the system takes too long</p> <p>Pressure operation:</p> <p>Filling the system takes too long</p> <p>Building up pressure in the system takes too long</p>	<p>Vacuum operation:</p> <p>The vacuum system or suction line is not leak-tight</p> <p>Pressure operation:</p> <p>The pressure system or pressure line is not leak-tight</p>	<p>Check the hose or pipe connections for possible leak</p>
	<p>In case a vacuum relief valve/regulating system is installed:</p> <p>The vacuum relief valve/regulating system is misadjusted or defective</p> <p>In case a pressure relief valve/regulating system is installed:</p> <p>The pressure relief valve/regulating system is misadjusted or defective</p>	<p>Adjust, repair or replace, respectively</p>
	<p>In case a screen is installed in the suction connection/gas inlet (a):</p> <p>The screen in the suction connection/gas inlet (a) is partially clogged</p>	<p>Clean the screen</p> <p>If cleaning is required too frequently install a filter upstream</p>
	<p>In case a filter (62, 63) is installed on the suction connection/gas inlet (a):</p> <p>The filter (62, 63) on the suction connection/gas inlet (a) is partially clogged</p>	<p>Clean or replace the inlet air filter (62, 63), respectively</p>
	<p>Partial clogging in the suction, discharge or pressure line</p>	<p>Remove the clogging</p>
	<p>Long suction, discharge or pressure line with too small diameter</p>	<p>Use larger diameter</p>
	<p>A vane (35) is blocked in the rotor or otherwise damaged</p>	<p>Free the vanes (35) or replace with new ones (Busch service)</p>
	<p>The radial clearance between the rotor and the cylinder is no longer adequate</p>	<p>Readjust the vacuum and pressure pump (Busch service)</p>
	<p>Internal parts are worn or damaged</p>	<p>Repair the vacuum and pressure pump (Busch service)</p>
<p>The gas conveyed by the vacuum and pressure pump smells displeasing</p>	<p>Process components evaporating under vacuum</p>	<p>Check the process, if applicable</p>

Version with AC-motor: The vacuum and pressure pump stops and re-starts after a certain time	The thermal protections switch of the drive activates due to insufficient cooling of the vacuum and pressure pump	Improve the cooling (increase the distance to adjacent walls, increase fresh air supply)
The vacuum and pressure pump does not start	The drive motor is not supplied with the correct voltage or is overloaded	Supply the drive motor with the correct voltage
	The drive motor starter overload protection is too small or trip level is too low	Compare the trip level of the drive motor starter overload protection with the data on the nameplate, correct if necessary In case of high ambient temperature: set the trip level of the drive motor starter overload protection 5 percent above the nominal drive motor current
	One of the fuses has blown	Check the fuses
	Version with alternating current motor: The drive motor capacitor is defective	Repair the drive (Busch service)
	The connection cable is too small or too long causing a voltage drop at the vacuum and pressure pump	Use sufficiently dimensioned cable
	The vacuum and pressure pump or the drive motor is blocked	Make sure the drive motor is disconnected from the power supply Remove the fan cover Try to turn the drive motor with the vacuum and pressure pump by hand If the vacuum and pressure pump is blocked: Repair the vacuum and pressure pump (Busch service)
The vacuum and pressure pump is blocked	The drive motor is defective	Replace the drive motor (Busch service)
	Solid foreign matter has entered the vacuum and pressure pump	Repair the vacuum and pressure pump (Busch service) Make sure the suction line is equipped with a screen If necessary additionally provide a filter
	Corrosion in the vacuum and pressure pump from remaining condensate	Repair the vacuum and pressure pump (Busch service) Check the process
	Version with three-phase motor: The vacuum and pressure pump was run in the wrong direction	Repair the vacuum and pressure pump (Busch service) When connecting the vacuum and pressure pump make sure the vacuum and pressure pump will run in the correct direction (→ page 5: Installation)
The vacuum and pressure pump starts, but labours or runs noisily or rattles The drive motor draws a too high current (compare with initial value after commissioning)	After shutting down the vacuum and pressure pump condensate ran into the pump chamber When the vacuum and pressure pump was re-started too much condensate was enclosed between the vanes (35) Condensate could not be compressed and thus broke a vane (35)	Repair the vacuum and pressure pump (Busch service) Make sure no condensate will enter the vacuum and pressure pump, if necessary provide a drip leg and a drain cock Drain condensate regularly
	Loose connection(s) in the drive motor terminal box Version with three-phase-motor: Not all drive motor coils are properly connected The drive motor operates on two phases only	Check the proper connection of the wires against the connection diagram Tighten or replace loose connections

	Version with three-phase motor: The vacuum and pressure pump runs in the wrong direction	Verification and rectification → page 4: Installation and Commissioning
	Foreign objects in the vacuum and pressure pump Broken vanes (35) Stuck bearings	Repair the vacuum and pressure pump (Busch service)
The vacuum and pressure pump runs very noisily	Defective bearings	Repair the vacuum and pressure pump (Busch service)
	Stuck vanes (35)	Repair the vacuum and pressure pump (Busch service)
The vacuum and pressure pump runs very hot	Insufficient air ventilation	Make sure that the cooling of the vacuum and pressure pump is not impeded by dust/dirt Clean the fan cowling, the fan wheel, the ventilation grille and the cooling fins Install the vacuum and pressure pump in a narrow space only if sufficient ventilation is ensured
	Ambient temperature too high	Observe the permitted ambient temperatures
	Temperature of the inlet gas too high	Observe the permitted temperatures for the inlet gas
	Mains frequency or voltage outside tolerance range	Provide a more stable power supply
	Partial clogging of filters or screens Partial clogging in the suction, discharge or pressure line	Remove the clogging
	Long suction, discharge or pressure line with too small diameter	Use larger diameter

# Exploded View

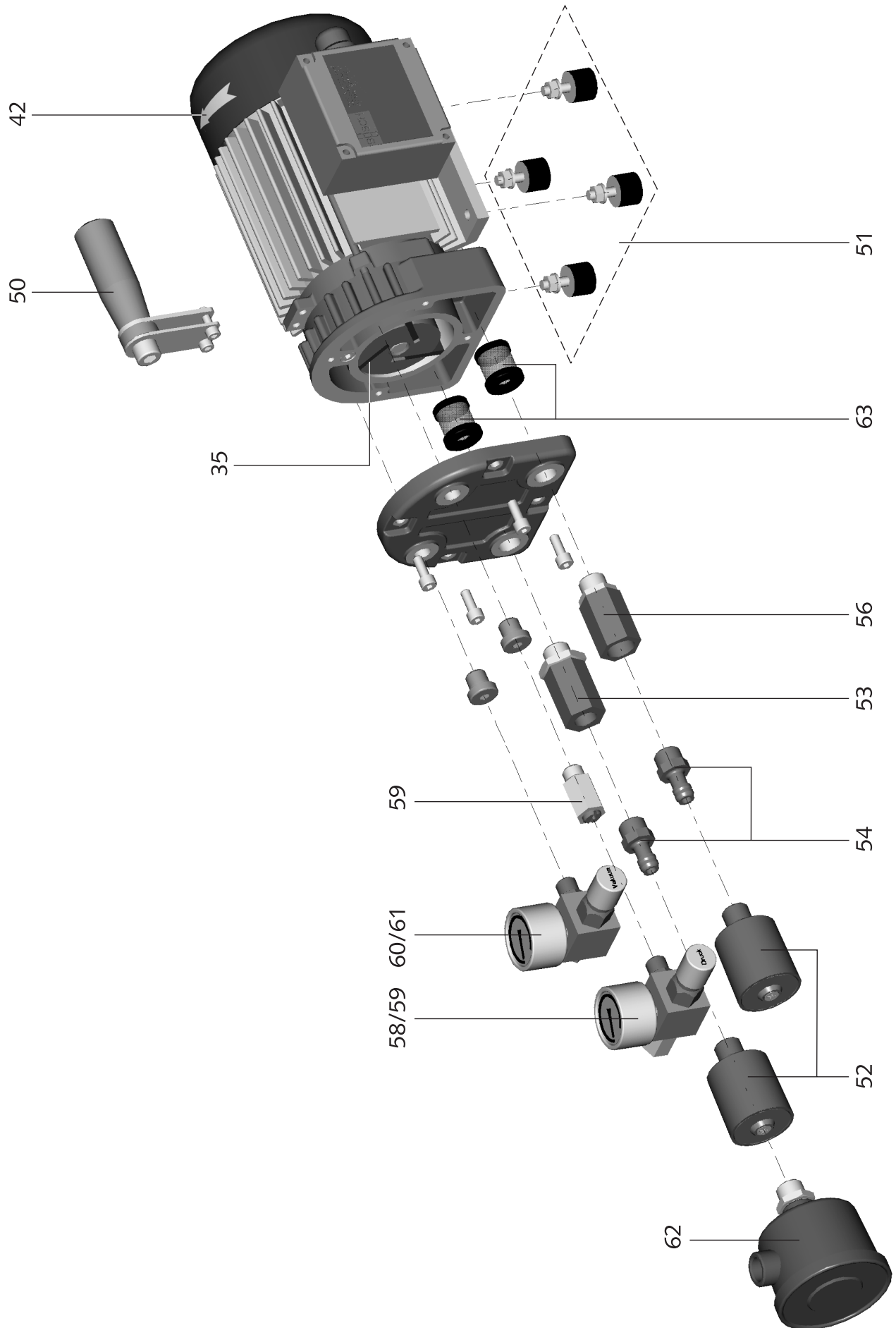

# Spare Parts/Accessories

**Note:** When ordering spare parts or accessories acc. to the table below please always quote the type ("Type") and the serial no. ("No") of the vacuum and pressure pump. This will allow Busch service to check if the vacuum and pressure pump is compatible with a modified or improved part.

**The exclusive use of genuine spare parts and consumables is a prerequisite for the proper function of the vacuum and pressure pump and for the granting of warranty, guarantee or goodwill.**

Your point of contact for service and spare parts in the United Kingdom:

Busch (UK) Ltd.  
Hortonwood 30-35  
Telford  
Shropshire  
TF1 7YB  
Tel: 01952 677 432  
Fax: 01952 677 423

Your point of contact for service and spare parts in Ireland:

Busch Ireland Ltd.  
A10-11 Howth Junction Business Centre  
Kilbarrack, Dublin 5  
Tel: +353 (0)1 8321466  
Fax: +353 (0)1 8321470

Your point of contact for service and spare parts in the USA:

Busch Inc.  
516-B Viking Drive  
Virginia Beach, VA 23452  
Tel: 1-800-USA-PUMP (872-7867)

Your point of contact for service and spare parts in Canada:

Busch Vacuum Technics Inc.  
1740, Boulevard Lionel Bertrand  
Boisbriand (Montréal)  
Québec J7H 1N7  
Tel: 450 435 6899  
Fax: 450 430 5132

Your point of contact for service and spare parts in Australia:

Busch Australia Pty. Ltd.  
30 Lakeside Drive  
Broadmeadows, Vic. 3047  
Tel: (03) 93 55 06 00  
Fax: (03) 93 55 06 99

Your point of contact for service and spare parts in New Zealand:

Busch New Zealand Ltd.  
Unit D, Arrenway Drive  
Albany, Auckland 1311  
P O Box 302696  
North Harbour, Auckland 1330  
Tel: 0-9-414 7782  
Fax: 0-9-414 7783

Find the list of Busch companies all over the world (by the time of the publication of these installation and operating instructions) on → page 16 (rear cover page).

Find the up-to-date list of Busch companies and agencies all over the world on the internet at [www.busch-vacuum.com](http://www.busch-vacuum.com).

53	Non-return valve, suction side (vacuum operation)	1	0947 134 347
54	Hose nipple G3/8 x 37 (vacuum and pressure operation)	2	0574 102 380
—	Small flange DN10 KF short, R3/8 (vacuum and pressure operation)	2	0450 000 032
56	Non-return valve, pressure side (pressure operation)	1	0947 134 294
57	Pressure regulation valve R1/4 (manual setting for pressure operation)	1	0540 000 015
58	Pressure regulation unit (with pressure regulation valve, manual setting, pressure gauge, for pressure operation)	1	0947 134 230
59	Pressure relief valve (safety valve for pressure operation)	1	0916 134 019
60	Vacuum regulation valve R1/4 (manual setting for vacuum operation)	1	0540 000 014
61	Vacuum regulation unit (with vacuum regulation valve, manual setting, vacuum gauge, for vacuum operation)	1	0947 134 229
62	Air filter, complete (external mounting, for increased dust load, for vacuum operation)	1	0945 121 564
—	Filter cartridge (for external filter)	1	0532 000 033
63	Filter cartridge (small internal filter)	2	0532 133 447

Pos.	Part	Qty	Part no.
35	Vane	3	0722 133 118
42	Directional arrow	1	0565 000 003
50	Handle (for mobile operation)	1	0957 133 879
51	Mounting (rubber feet for vibration insulated mounting)	1	0956 133 878
52	Silencer (suction and pressure side, vacuum and pressure operation)	2	0947 133 870

# EC-Declaration of Conformity

**Note:** This Declaration of Conformity and the CE-mark affixed to the nameplate are valid for the machine within the Busch scope of delivery. This Declaration of Conformity is issued under the sole responsibility of the manufacturer.

When this machine is integrated into a superordinate machinery the manufacturer of the superordinate machinery (this can be the operating company, too) must conduct the conformity assessment process for the superordinate machine or plant, issue the Declaration of Conformity for it and affix the CE-mark.

We

**Busch Vyroba CZ s.r.o.**  
**Svárovská 620,**  
**CZ 460 01, Liberec 11**  
**Czech Republic**

Declare that the vacuum pumps **SV 1005 C / SD 1005 C / SV 1008 C / SD 1008 C**

with a serial number from **D1701...** to **D1952...**

has (have) been manufactured in accordance with the European Directives:

- 'Machinery' 2006/42/EC
- 'Electromagnetic Compatibility' 2014/30/EU
- 'RoHS' 2011/65/EU, restriction of the use of certain hazardous substances in electrical and electronic equipment

and following the standards.

Standard	Title of the Standard
EN ISO 12100: 2010	Safety of machinery –General principles for design –Risk assessment and risk reduction
EN ISO 13857: 2008	Safety of machinery - Safety distances to prevent hazard zones being reached by the upper and lower limbs
EN 1012-1: 2010 EN 1012-2: 1996 + A1: 2009	Compressors and vacuum pumps - Safety requirements - Part 1 and Part 2
EN ISO 2151: 2008	Acoustics - Noise test code for compressors and vacuum pumps - Engineering method (grade 2)
EN 60204-1: 2006	Safety of machinery - Electrical equipment of machines - Part 1: General requirements
EN 61000-6-2: 2005	Electromagnetic compatibility (EMC) - Generic immunity standards. Immunity for industrial environments
EN 61000-6-4: 2007 + A1: 2011	Electromagnetic compatibility (EMC) - Generic immunity standards. Emission standard for industrial environments
EN ISO 13849-1:2015 <sup>(1)</sup>	Safety of machinery - Safety-related parts of control systems - Part 1: General principles for design

Manufacturer	Person authorized to compile the technical file
	
<b>Michael Dostalek</b> General Director	<b>Gerd Rohweder</b> Technical writer

Liberec, 25.10.2017

# Technical Data

For motor connection parameters see nameplate

			SV 1005 C	SD 1005 C	SV 1008 C	SD 1008 C
Nominal suction capacity	m <sup>3</sup> /h	50 Hz	4.6	—	7.3	—
		60 Hz	5.5	—	8.8	—
Volume flow	m <sup>3</sup> /h	50 Hz	—	4.6	—	7.3
		60 Hz	—	5.5	—	8.8
Ultimate pressure	hPa abs. (mbar abs)		150	—	150	—
Overpressure (= max. allowed backpressure)	bar g		—	1	—	1
Nominal motor rating	kW	50 Hz	0.14	0.25	0.25	0.37
		60 Hz	0.18	0.3	0.3	0.45
Nominal speed	min <sup>-1</sup>	50 Hz	3000	3000	3000	3000
		60 Hz	3600	3600	3600	3600
Sound pressure level (EN ISO 2151) with silencer	db(A)	50 Hz	59	60	61	62
		60 Hz	60	61	62	63
Weight	kg		8	8.5	8.5	9
Ambient temperature range	° C		-10 ... +40			

## Australia

Busch Australia Pty. Ltd.  
30 Lakeside Drive  
Broadmeadows, Vic. 3047  
Tel: (03) 93 55 06 00  
Fax: (03) 93 55 06 99

## Austria

Busch Austria GmbH  
Industriepark Nord  
2100 Korneuburg  
Tel: 02262 / 756 65-0  
Fax: 02262 / 756 65-20

## Belgium

Busch N.V./Busch SA  
Kruinstraat 7  
9160 Lokeren  
Tel: (0)9 / 348 47 22  
Fax: (0)9 / 348 65 35

## Brazil

Busch do Brasil Ltda.  
Rod. Edgard Máximo Zambotto, Km 64  
13240-000 Jarinu-SP  
Tel: (55) 11-4016 1400/5277  
Fax: (55) 11-4016 5399

## Canada

Busch Vacuum Technics Inc.  
1740, Boulevard Lionel Bertrand  
Boisbriand (Montréal)  
Québec J7H 1N7  
Tel: 450 435 6899  
Fax: 450 430 5132

## Chile

Busch Chile S. A.  
Calle El Roble N° 375-G  
Lampa - Santiago  
Tel: (56-2) 7387092  
Fax: (56-2) 7387092

## China

Busch Vacuum (Shanghai) Co., Ltd  
No.5, Lane 195 Xipu Road  
Songjiang Industrial Estate East New Zone  
Shanghai 201611 PRC  
Tel: +86 (0)21 67600800  
Fax: +86 (0)21 67600700

## Czech Republic

Busch Vakuu s.r.o.  
Pražákova 10  
619 00 Horní Heršpice  
Brno  
Tel: +420 543 42 48 55  
Fax: +420 543 42 48 56

## Denmark

Busch Vakuu teknik A/S  
Parallevej 11  
8680 Ry  
Tel: +45 87 88 07 77  
Fax: +45 87 88 07 88

## Finland

Busch Vakuu teknik Oy  
Sinikellontie 4  
01300 VANTAA  
Tel: 09 774 60 60  
Fax: 09 774 60 666

## France

Busch France S.A.  
Parc Technologique  
de Bois Chaland CE 2922  
91029 Evry Cedex  
Tel: 01 69 89 89 89  
Fax: 01 60 86 16 74

## Germany

Dr.-Ing. K. Busch GmbH  
Schauinslandstr. 1  
79689 Maulburg  
Tel: (0 76 22) 6 81-0  
Fax: (0 76 22) 6 81-194  
e-mail: info@busch.de

Dr.-Ing. K. Busch GmbH  
Niederlassung Nord  
Ernst-Abbe-Str. 1-3  
25451 Quickborn  
Tel: (0 41 06) 7 99 67-0  
Fax: (0 41 06) 7 99 67-77

Dr.-Ing. K. Busch GmbH  
Niederlassung West  
Nordring 35  
64807 Dieburg  
Tel: (0 60 71) 92 82-0  
Fax: (0 60 71) 14 71

Dr.-Ing. K. Busch GmbH  
Außenstelle Neuenrade  
Breslauer Str. 36  
58809 Neuenrade  
Tel: (0 23 92) 50 29 92  
Fax: (0 23 92) 50 72 11

Dr.-Ing. K. Busch GmbH  
Niederlassung Süd-Ost  
Gewerbestraße 3  
90579 Langenzenn  
Tel: (09 01) 90 25-0  
Fax: (09 01) 90 25-25

Dr.-Ing. K. Busch GmbH  
Außenstelle Zella-Mehlis  
Am Rain 11  
98544 Zella-Mehlis  
Tel: (0 36 82) 46 92 71  
Fax: (0 36 82) 46 92 73

Dr.-Ing. K. Busch GmbH  
Außenstelle Meitingen-Ostendorf  
Grüntenweg 8  
86405 Meitingen-Ostendorf  
Tel: (0 82 71) 426-341  
Fax: (0 82 71) 426-342

## India

Busch Vacuum India Pvt Ltd.  
Plot No. 110, Sector 7  
PCNTDA, Bhosari  
Pune 411026, Maharashtra  
Tel: (0)206410 2886  
Fax: (0)202711 2838

## Ireland

Busch Ireland Ltd.  
A10-11 Howth Junction Business Centre  
Kilbarrack, Dublin 5  
Tel: 00353 1 832 1466  
Fax: 00353 1 832 1470

## Israel

Busch Israel Ltd.  
1 Mevo Sivan Street  
Qiryat Gat 82022, Israel  
Tel: +972 (0)8 6810485  
Fax: +972 (0)8 6810486

## Italy

Busch Italia S.r.l.  
Via Ettore Majorana, 16  
20054 Nova Milanese  
Tel: 0362 370 91  
Fax: 0362 370 999

## Japan

Nippon Busch K.K.  
1-23-33, Megumigaoka  
Hiratsuka City, Kanagawa  
Japan 259-1220  
Tel: 0463-50-4000  
Fax: 0463-50-4004

## Korea

Busch Korea Ltd.  
392-1 Yangji-Ri, Yangji-Myun,  
Yongin-si, Kyunggi-Do  
Tel: (031) 321-8114  
Fax: 031) 321 4330

## Malaysia

Busch (Malaysia) Sdn Bhd.  
6 Jalan Taboh 33/22  
Shah Alam Technology Park  
Section 33  
40400 Shah Alam  
Selangor D. E.  
Tel: 03 5122 2128  
Fax: 03 5122 2108

## Mexico

Busch Vacuum Mexico S de RL de CV  
Tlaquepaque 4865, Los Altos  
Monterrey, Nuevo Leon  
Mexico 64370  
Tel: (81) 8311-1385  
Fax: (81) 8311-1386

## Netherlands

Busch B.V.  
Pompomolenlaan 2  
3447 GK Woerden  
Postbus 2091  
3440 DB Woerden  
Tel: (0)348 - 462300  
Fax: (0)348 - 422939

## New Zealand

Busch New Zealand Ltd.  
Unit D, 41 Arrenway Drive  
Albany 0632  
Auckland  
Tel: 09 414 7782  
Fax: 09 414 7783

## Norway

Busch Vakuu teknik AS  
Hestehagen 2  
1440 Drøbak  
Tel: 64 98 98 50  
Fax: 64 93 66 21

## Poland

Busch Polska Sp. z o.o.  
Ul. Chopina 27  
87800 Włocławek  
Tel: (054) 2315400  
Fax: (054) 2320706

## Portugal

Busch Ibérica S.A., Sucursal em Portugal  
Zona Industrial Raso de Travassô, Fração B, Armazém 2  
3750-753 Agueda  
Aveiro, Portugal  
Tel: +351 234 648 070  
Fax: +351 234 648 068

## Singapore

Busch Vacuum Singapore Pte Ltd  
20 Shaw Road  
#01-03 Ching Shine Building  
Singapore 36 79 56  
Tel: (65) 6488 0866  
Fax: (65) 6288 0877

## Spain

Busch Ibérica S.A.  
C/ Jaume Ferran, 6-8  
Pol. Ind. Coll de la Manyà  
08403 Granollers  
Tel: +34 93 861 61 60  
Fax: +34 93 840 91 56

## Sweden

Busch Vakuu teknik AB  
Bråta Industriområde  
435 33 Mölnlycke  
Tel: 031 - 338 00 80  
Fax: 031 - 338 00 89

## Switzerland

Busch AG  
Waldweg 22  
4312 Magden  
Tel: 061 / 845 90 90  
Fax: 061 / 845 90 99

## Taiwan

Busch Taiwan Corporation  
1F. No. 69, Sec. 3, Beishen Rd.  
Shenkeng Township,  
Taipei Country,  
Taiwan (222), R.O.C  
Tel: (02) 2662 0775  
Fax: (02) 2662 0796

## Thailand

Busch Vacuum (Thailand) Co., Ltd.  
888/30 Moo19, Soi Yingcharoen, Bangplee-Tamru Rd.,  
Bangpleeyai, Bangplee, Samutprakarn 10540 Thailand  
Tel: (66) 2-382-5428  
Fax: (66) 2-382-5429

## Turkey

VAKUTEK  
Emlak Kredi Ishani No: 179  
81130 Üsküdar-Istanbul  
Tel: (216) 310 0573  
Fax: (216) 343 5126

## United Kingdom

Busch (UK) Ltd  
Hortonwood 30-35  
Telford Shropshire TF1 7YB  
Tel: 01952 677 432  
Fax: 01952 677 423

## USA

Busch, Inc.  
516-B Viking Drive  
Virginia Beach, VA 23452  
Tel: (757) 463-7800  
Fax: (757) 463 7407

Semiconductor Vacuum Group Inc.  
Morgan Hill, CA 95037  
Tel: (408) 955 1900  
Fax: (408) 955 0229