

MINK MH 0018 A

Dry claw compressor

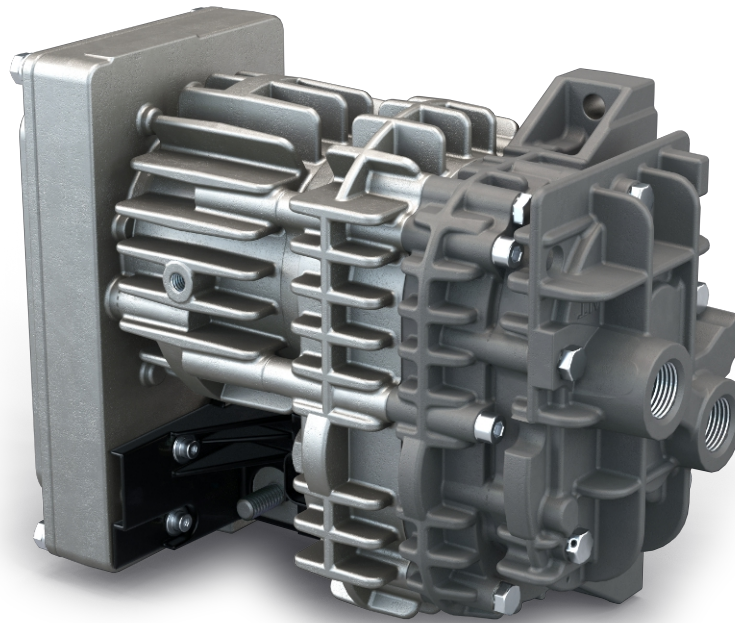

VACUUM SOLUTIONS



Hydrogen-approved

For recirculation of hydrogen in fuel cells under extreme conditions, only hydrogen-approved compressor in the market

Efficient

Latest claw technology, intelligent variable speed drive

Compact

Small footprint due to "all-in-one" design with integrated variable speed drive

MINK MH 0018 A

Dry claw compressor



VACUUM SOLUTIONS

Dimensional drawing

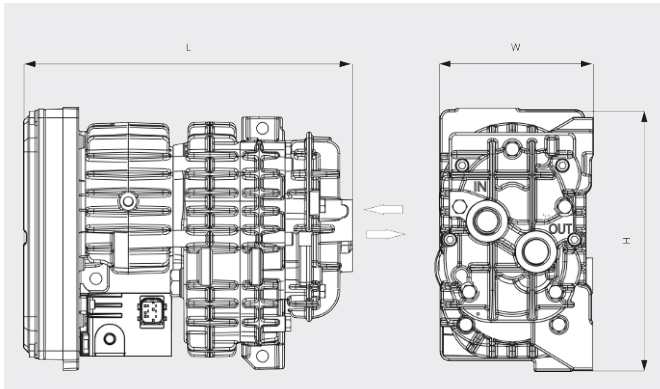

Pumping speed
Air at 20°C. Tolerance: ± 10%

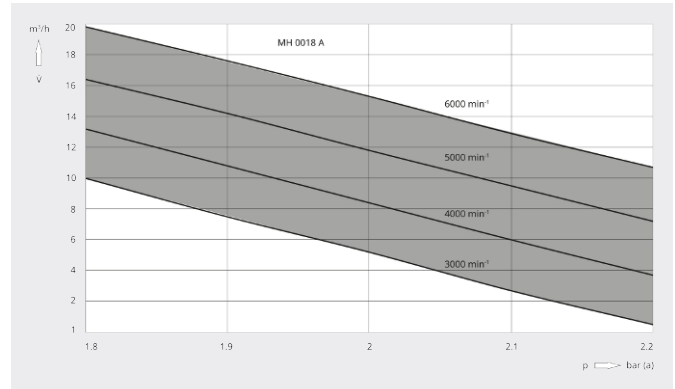

MINK MH 0018 A	
Volume flow (at inlet)	max. 18 m ³ /h
Overpressure	max. 0.4 bar(g)
Leakage rate (EU 79/2009 and 406/2010)	< 10 Ncm ³ /h
Nominal motor rating	max. 0.5 kW
Nominal motor speed	480 – 6000 min ⁻¹
Noise level (ISO 2151)	68 – 73 / 68 – 73 dB(A) (3000 / 6000 min ⁻¹)
Oil capacity	0.1 l
Weight approx.	6.5 kg
Dimensions (L x W x H)	249.5 x 120 x 199 mm

DO YOU WANT TO KNOW MORE?

Get in touch with us directly!



CONTACT FORM