

# APOVAC AP 0260/0330 A

Vacuum systems for chemical and pharmaceutical industries



VACUUM SOLUTIONS



## Proven performance

Standard vacuum system with proven DOLPHIN liquid ring vacuum pumps, specially designed for major processes in chemical and pharmaceutical industries, such as distillation, crystallization, filtration, vacuum drying

## Robust

Handling of toxic, corrosive or explosive gases, extremely high vapor and particle tolerance, for harsh process conditions, double condensation to ensure minimum carryover and maximum solvent recovery

## Cost-effective

Low operating costs, high uptime, minimal maintenance, long service life

# APOVAC AP 0260/0330 A

Vacuum systems for chemical and pharmaceutical industries



Dimensional drawing

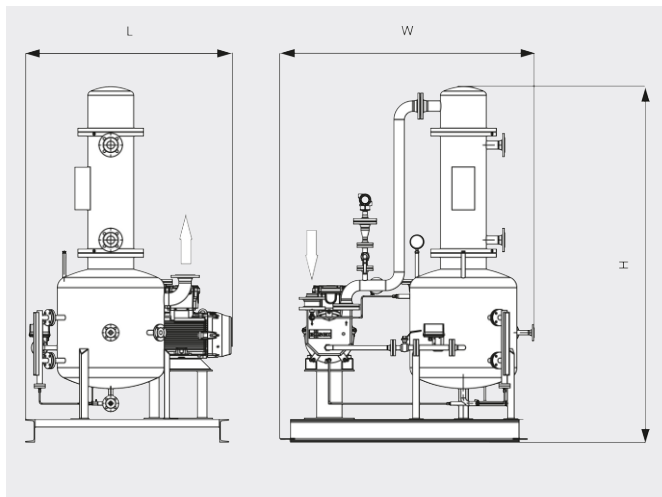

Pumping speed

Air at 20°C. Tolerance: ± 10%

— Vacuum pump ..... Ejector

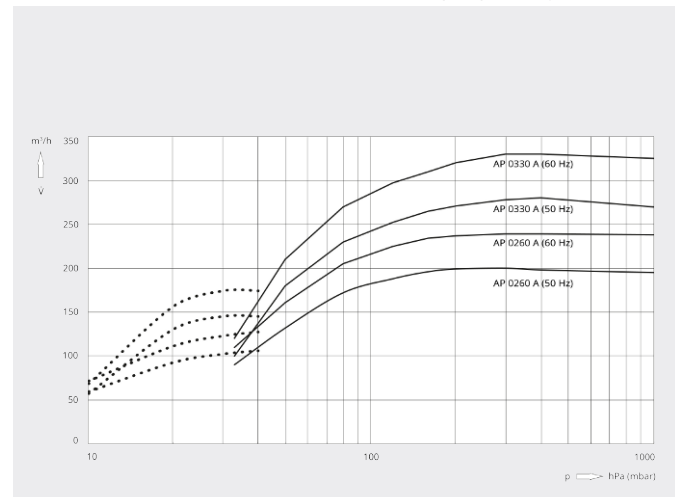

	APOVAC AP 0260 A	APOVAC AP 0330 A
<b>Nominal pumping speed</b>	200 / 240 m <sup>3</sup> /h (50 / 60 Hz)	280 / 330 m <sup>3</sup> /h (50 / 60 Hz)
<b>Ultimate pressure</b>	33 / 10 (with optional ejector) hPa (mbar) (50 / 60 Hz)	33 / 10 (with optional ejector) hPa (mbar) (50 / 60 Hz)
<b>Nominal motor rating</b>	5.5 / 7.5 kW (50 / 60 Hz)	7.5 / 11.0 kW (50 / 60 Hz)
<b>Nominal motor speed</b>	1450 / 1750 min <sup>-1</sup> (50 / 60 Hz)	1450 / 1750 min <sup>-1</sup> (50 / 60 Hz)
<b>Weight approx.</b>	700 kg	750 kg
<b>Dimensions (L x W x H)</b>	1400 x 1300 x 2300 mm	1400 x 1300 x 2300 mm
<b>Gas inlet / outlet</b>	DN 50 / DN 65	DN 50 / DN 65

DO YOU WANT TO KNOW MORE?

Get in touch with us directly!



CONTACT FORM