

# R5

Rotary Vane Vacuum Pumps  
RA 0063 F 5K

## Instruction Manual



# Table of Contents

<b>1</b>	<b>Safety</b> .....	<b>3</b>
<b>2</b>	<b>Product Description</b> .....	<b>4</b>
2.1	Operating Principle .....	5
2.2	Intended Use .....	5
2.3	Start Controls.....	6
2.4	Optional Accessories.....	6
2.4.1	Gas Ballast Valve .....	6
2.4.2	Inlet Filter .....	6
2.4.3	Level Switch .....	6
<b>3</b>	<b>Transport</b> .....	<b>7</b>
<b>4</b>	<b>Storage</b> .....	<b>9</b>
<b>5</b>	<b>Installation</b> .....	<b>10</b>
5.1	Installation Conditions.....	10
5.2	Connecting Lines / Pipes .....	11
5.2.1	Suction Connection.....	11
5.2.2	Discharge Connection .....	11
5.3	Filling Oil.....	12
<b>6</b>	<b>Electrical Connection</b> .....	<b>13</b>
6.1	Machine delivered without Control Box or Variable Speed Drive (VSD).....	13
6.2	Wiring Diagram Single-Phase Motor .....	14
6.3	Wiring Diagram Three-Phase Motor.....	14
6.4	Electrical Connection of the Monitoring Devices .....	15
6.4.1	Wiring Diagram Level Switch (Optional) .....	15
<b>7</b>	<b>Commissioning</b> .....	<b>16</b>
7.1	Version with Oil Return Valve .....	16
7.2	Conveying Condensable Vapors.....	16
<b>8</b>	<b>Maintenance</b> .....	<b>18</b>
8.1	Maintenance Schedule .....	19
8.2	Oil Level Inspection .....	19
8.3	Oil and Oil Filter Change .....	20
8.4	Exhaust Filter Change.....	22
<b>9</b>	<b>Overhaul</b> .....	<b>23</b>
<b>10</b>	<b>Decommissioning</b> .....	<b>24</b>
10.1	Dismantling and Disposal .....	24
<b>11</b>	<b>Spare Parts</b> .....	<b>25</b>
<b>12</b>	<b>Troubleshooting</b> .....	<b>26</b>
<b>13</b>	<b>Technical Data</b> .....	<b>28</b>
<b>14</b>	<b>Oil</b> .....	<b>29</b>
<b>15</b>	<b>EU Declaration of Conformity</b> .....	<b>30</b>
<b>16</b>	<b>UK Declaration of Conformity</b> .....	<b>31</b>

# 1 Safety

Prior to handling the machine, this instruction manual should be read and understood. If anything needs to be clarified, please contact your Busch representative.

Read this manual carefully before use and keep for future reference.

This instruction manual remains valid as long as the customer does not change anything on the product.

The machine is intended for industrial use. It must be handled only by technically trained personnel.

Always wear appropriate personal protective equipment in accordance with the local regulations.

The machine has been designed and manufactured according to state-of-the-art methods. Nevertheless, residual risks may remain, as described in the following chapters and in accordance with the chapter *Intended Use* [→ 5]. This instruction manual highlights potential hazards where appropriate. Safety notes and warning messages are tagged with one of the keywords DANGER, WARNING, CAUTION, NOTICE and NOTE as follows:



## DANGER

... indicates an imminent dangerous situation that will result in death or serious injuries if not prevented.



## WARNING

... indicates a potentially dangerous situation that could result in death or serious injuries.



## CAUTION

... indicates a potentially dangerous situation that could result in minor injuries.



## NOTICE

... indicates a potentially dangerous situation that could result in damage to property.



## NOTE

... indicates helpful tips and recommendations, as well as information for efficient and trouble-free operation.

## 2 Product Description

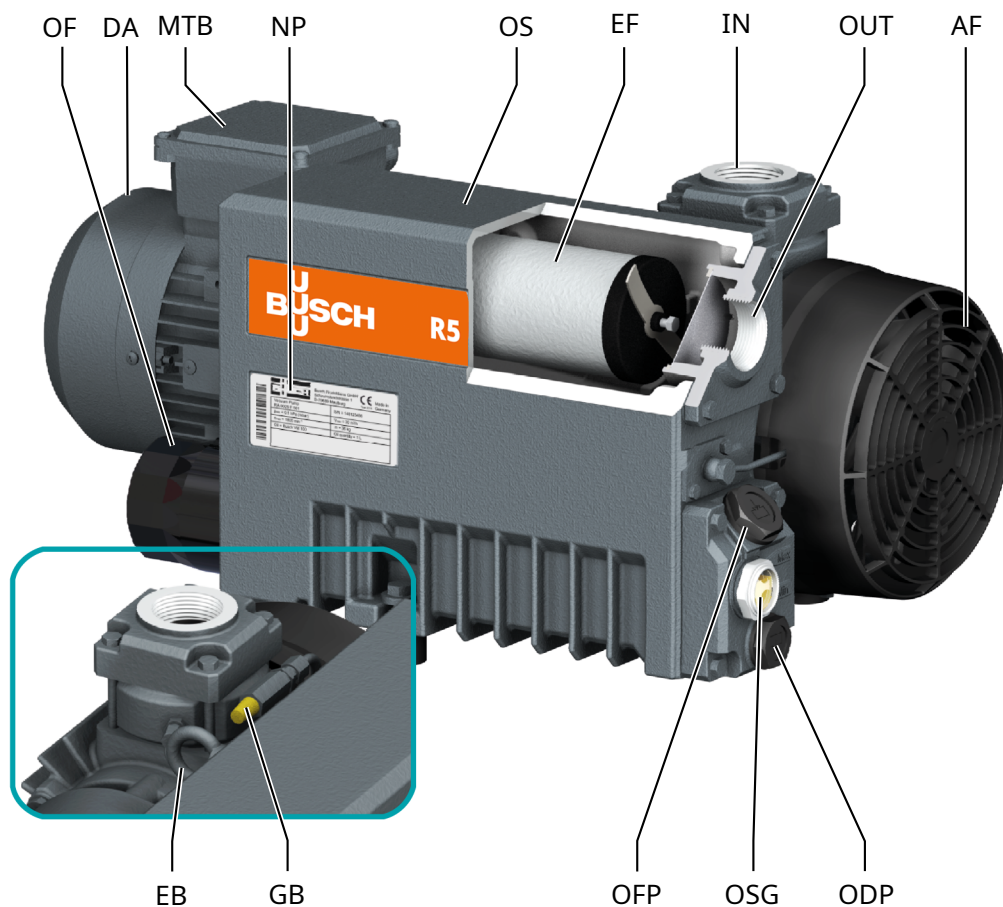

### Description

OF	Oil filter	DA	Directional arrow
MTB	Motor terminal box	NP	Nameplate
OS	Oil separator	EF	Exhaust filter
IN	Suction connection	OUT	Discharge connection
AF	Axial fan	EB	Eye bolt
GB	Gas ballast valve	OFP	Oil fill plug
OSG	Oil sight glass	ODP	Oil drain plug



### NOTE

Technical term.

In this instruction manual, we consider that the term 'machine' refers to the 'vacuum pump'.



### NOTE

Illustrations

In this instruction manual the illustrations may differ from the machine appearance.

## 2.1 Operating Principle

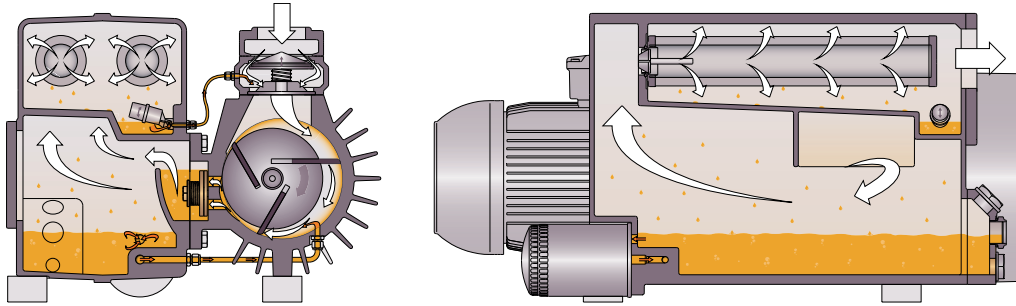

The machine works on the rotary vane principle.

The oil seals the gaps, lubricates the vanes and takes away compression heat.

In order to avoid reverse rotation after switching off, the machine is equipped with a non-return valve (NRV).

In order to avoid solids from entering, the machine is equipped with an inlet screen (IS).

The oil filter cleans the circulating oil.

Exhaust filters separate the oil from the discharged gas.

## 2.2 Intended Use



### WARNING

**In case of foreseeable misuse outside the intended use of the machine.**

**Risk of injuries!**

**Risk of damages to the machine!**

**Risk of damages to the environment!**

- Make sure to follow all instructions described in this manual.

The machine is intended for the suction of air and other dry, non-aggressive, non-toxic and non-explosive gases.

Conveying of other media leads to an increased thermal and/or mechanical load on the machine and is permissible only after a consultation with Busch.

The machine is intended for the placement in a non-potentially explosive environment.

The machine is designed for indoor installation, in case of outdoor installation, ask your Busch representative in order to take specific precautions.

The machine is capable of maintaining ultimate pressure, see *Technical Data* [→ 28].

Version with float valve (standard):

The machine is suitable for continuous operation.

Version with oil return valve:

During operation oil accumulates at the bottom of the upper chamber of the oil separator, which cannot flow down into the bottom chamber, as long as the machine runs. After 10 h of continuous operation near ultimate pressure, in case of operation in rough vacuum, after a shorter time:

- The machine must be shut down for at least 15 min
- The oil can run down from the upper chamber of the oil separator into the bottom chamber.

The machine is suitable for continuous operation up to 100 mbar.

Permitted environmental conditions, see *Technical Data* [→ 28].

## 2.3 Start Controls

The machine comes without start controls. The control of the machine is to be provided in the course of installation.

The machine can be equipped with a soft-starter.

## 2.4 Optional Accessories

### 2.4.1 Gas Ballast Valve

The gas ballast valve mixes the process gas with a limited quantity of ambient air to counteract the condensation of vapor inside the vacuum pump.

The gas ballast valve has an influence on the ultimate pressure of the machine, see *Technical Data* [→ 28].

### 2.4.2 Inlet Filter

The inlet filter protects the machine against dust and other solids in the process gas. The inlet filter is available with a paper or polyester cartridge.

### 2.4.3 Level Switch

The level switch monitors the oil level in the oil separator (OS).

## 3 Transport



### WARNING

**Suspended load.**

**Risk of severe injury!**

- Do not walk, stand or work under suspended loads.



### WARNING

**Lifting the machine using the motor eye bolt.**

**Risk of severe injury!**

- Do not lift the machine using the eye bolt fitted to the motor. Only lift the machine as shown.



### NOTICE

**In case the machine is already filled with oil.**

**Tilting a machine that is already filled with oil can cause large quantities of oil to ingress into the cylinder. Starting the machine with excessive quantities of oil in the cylinder will immediately break the vanes and ruin the machine!**

- Drain the oil prior to every transport or always horizontally transport the machine.
- To find out the weight of the machine, refer to the chapter *Technical Data* [→ 28] or the nameplate (NP).
- Make sure that the eye bolt(s) (EB) is/are in faultless condition, fully screwed in and tightened by hand.

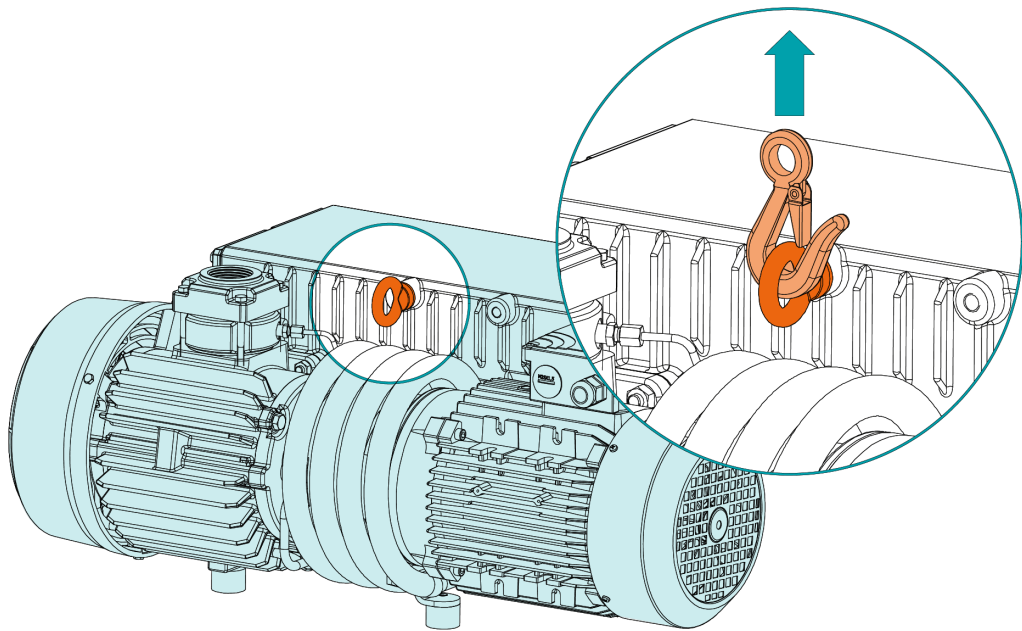

- Check the machine for transport damage.

If the machine is secured to a base plate:

- Remove the machine from the base plate.



## 4 Storage

- Seal all apertures with adhesive tape or reuse provided caps.

If the machine is to be stored for more than 3 months:

- Wrap the machine in a corrosion inhibiting film.
- Store the machine indoors, dry, dust free and if possible in original packaging preferably at temperatures between 0 ... 40 °C.

## 5 Installation

### 5.1 Installation Conditions



#### NOTICE

**Use of the machine outside of the permitted installation conditions.**

**Risk of premature failure!**

**Loss of efficiency!**

- Take care that the installation conditions are fully complied with.

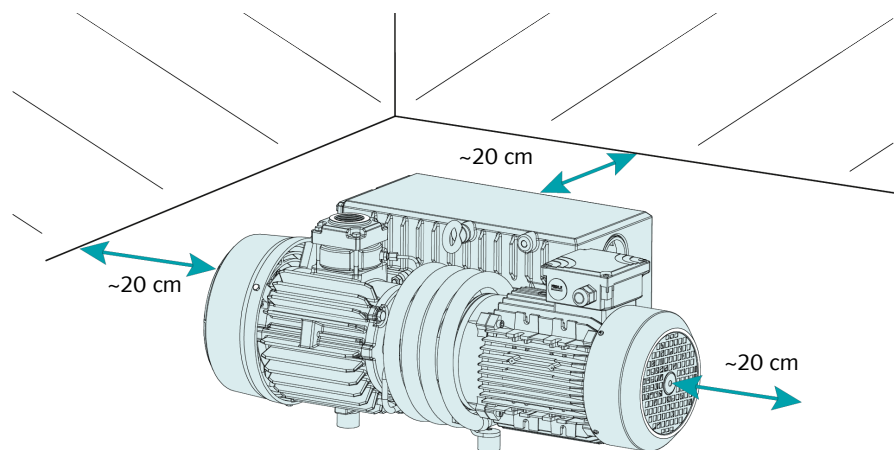

- Make sure that the environment of the machine is not potentially explosive.
- Make sure that the ambient conditions comply with the *Technical Data* [→ 28].
- Make sure that the environmental conditions comply with the protection class of the motor and the electrical elements.
- Make sure that the installation space or location is protected from weather and lightning.
- Make sure that the installation space or location is vented such that sufficient cooling of the machine is provided.
- Make sure that cooling air inlets and outlets are not covered or obstructed and that the cooling air flow is not affected adversely in any other way.
- Make sure that the oil sight glass (OSG) remains easily visible.
- Make sure that enough space remains for maintenance work.
- Make sure that the machine is placed or mounted horizontally, a maximum of 1° in any direction is acceptable.
- Check the oil level, see *Oil Level Inspection* [→ 19].
- Make sure that all provided covers, guards, hoods, etc. are mounted.

If the machine is installed at an altitude greater than 1000 meters above sea level:

- Contact your Busch representative, the motor should be derated or the ambient temperature limited.

## 5.2 Connecting Lines / Pipes

- Remove all protective covers before installation.
- Make sure that the connection lines cause no stress on the machine's connection; if necessary use flexible joints.
- Make sure that the line size of the connection lines over the entire length is at least as large as the connections of the machine.

In case of long connection lines it is advisable to use larger line sizes in order to avoid a loss of efficiency. Seek advice from your Busch representative.

### 5.2.1 Suction Connection



#### NOTICE

**Ingress of foreign objects or liquids.**

**Risk of damage to the machine!**

If the inlet gas contains dust or other foreign solid particles:

- Install a suitable filter (5 micron or less) upstream from the machine.

Connection size(s):

- G1 1/4

Depending on the specific configuration ordered, other connection dimensions may apply.

### 5.2.2 Discharge Connection



#### CAUTION

**The discharge gas contains small quantities of oil.**

**Risk to health!**

If air is discharged into rooms where persons are present:

- Make sure that sufficient ventilation is provided.



#### NOTICE

**Discharge gas flow obstructed.**

**Risk of damage to the machine!**

- Make sure that the discharged gas will flow without obstruction. Do not shut off or throttle the discharge line or use it as a pressurized air source.

Connection size(s):

- G1 1/4

Depending on the specific configuration ordered, other connection dimensions may apply.

Unless the aspirated air is discharged to the environment right at the machine:

- Make sure that the discharge line either slopes away from the machine or provide a liquid separator or a siphon with a drain cock, so that no liquids can flow back into the machine.

## 5.3 Filling Oil

### ! NOTICE

**Use of an inappropriate oil.**

**Risk of premature failure!**

**Loss of efficiency!**

- Only use an oil type which has previously been approved and recommended by Busch.

For oil type and oil capacity see *Technical Data* [→ 28] and *Oil* [→ 29].

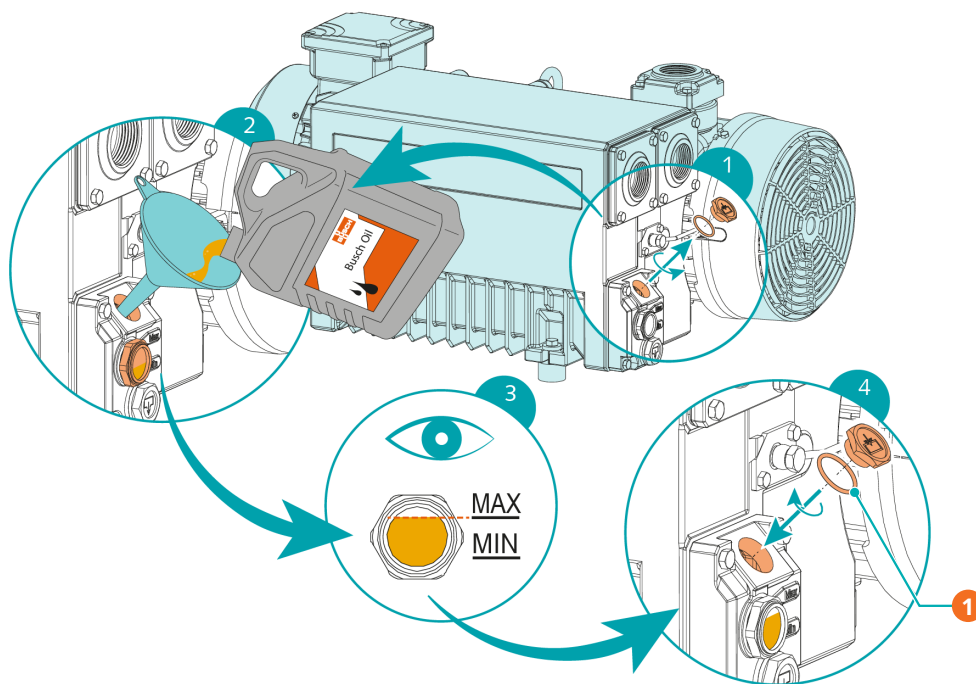

#### Description

1	1x o-ring, part no.: 0486 000 590
---	-----------------------------------

## 6 Electrical Connection



### DANGER

**Live wires.**

**Risk of electrical shock.**

- Electrical installation work must only be executed by qualified personnel.

#### CURRENT PROTECTION OF THE CUSTOMER INSTALLATION:



### DANGER

**Missing current protection.**

**Risk of electrical shock.**

- Current protection according to EN 60204-1 must be insured by the customer on its installation.
- The electrical installation must comply with the applicable national and international standards.



### NOTICE

**Electromagnetic compatibility.**

- Make sure that the motor of the machine will not be affected by electric or electro-magnetic disturbance from the mains, if necessary seek advice from Busch.
- Make sure that the EMC of the machine is compliant with the requirements of your supply network system, if necessary provide further interference suppression (EMC of the machine, see *EU Declaration of Conformity* [→ 30] or *UK Declaration of Conformity* [→ 31]).

### 6.1 Machine delivered without Control Box or Variable Speed Drive (VSD)



### DANGER

**Live wires.**

**Risk of electrical shock.**

- Electrical installation work must only be executed by qualified personnel.
- Make sure that the power supply for the motor is compatible with the data on the nameplate of the motor.
- If the machine is equipped with a power connector, install a residual current protective device to protect persons in case of isolation default.
  - Busch recommends installing a type B residual protective device suitable for the electrical installation.
- Provide a lockable disconnect switch or an emergency stop switch on the power line so that the machine is completely secured in case of an emergency situation.

- Provide a lockable disconnect switch on the power line so that the machine is completely secured during maintenance tasks.
- Provide an overload protection according to EN 60204-1 for the motor.
  - Busch recommends installing a D-curve circuit breaker.
- Connect the protective earth conductor.
- Electrically connect the motor.



## NOTICE

**Incorrect connection.**

**Risk of damage to the motor!**

- The wiring diagrams given below are typical. Check the inside of the terminal box for motor connection instructions/diagrams.

## 6.2 Wiring Diagram Single-Phase Motor

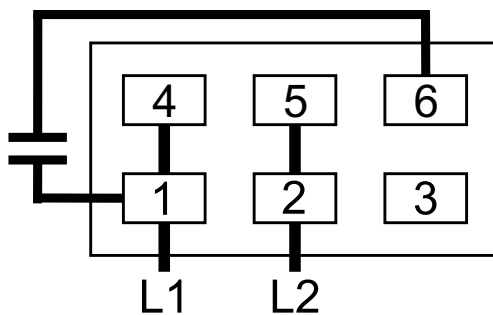

## 6.3 Wiring Diagram Three-Phase Motor



## NOTICE

**Incorrect direction of rotation.**

**Risk of damage to the machine!**

- Operation in the wrong direction of rotation can destroy the machine in a short time! Prior to start-up, ensure that the machine is operated in the right direction.

- Determine the intended direction of rotation with the arrow (stuck on or cast).
- Jog the motor briefly.
- Watch the fan wheel of the motor and determine the direction of rotation just before the fan wheel stops.

If the rotation of the motor must be changed:

- Switch any two of the motor phase wires.

Delta connection (low voltage):

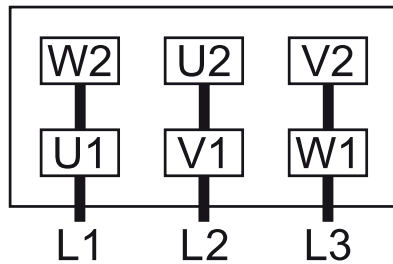

Star connection (high voltage):

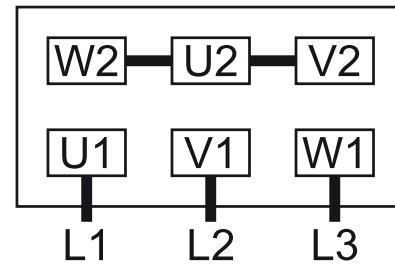

Double star connection, multi-voltage motor with 9 pins (low voltage):

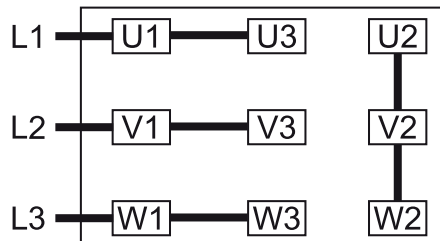

Star connection, multi-voltage motor with 9 pins (high voltage):

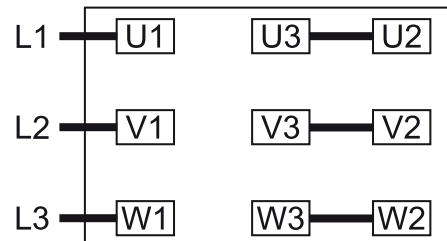

## 6.4 Electrical Connection of the Monitoring Devices



### NOTE

In order to prevent potential nuisance alarms, Busch recommends that the control system is configured with a time delay of at least 20 seconds.

### 6.4.1 Wiring Diagram Level Switch (Optional)

Part no.: 0652 203 669

#### Electrical data:

U = max. 250 V

$I_{max} = 1.0$  A

P = 50 W/VA

IP 65

#### Switching element function:

Reed-contact

**Contact:** 2x NO with isolated voltage and signal output

#### Switch point:

$S1_{trip}$  ► pin 1 + 2 ► min. level

$S2_{trip}$  ► pin 3 + 4 ► max. level

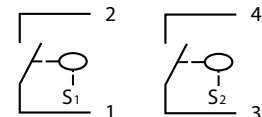
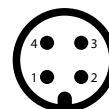

## 7 Commissioning

### NOTICE

The machine can be shipped without oil.

**Operation without oil will ruin the machine in short time!**

- Prior to commissioning, the machine must be filled with oil, see *Filling Oil* [→ 12].



### CAUTION

During operation the surface of the machine may reach temperatures of more than 70°C.

**Risk of burns!**

- Avoid contact with the machine during and directly after operation.

### CAUTION



**Noise of running machine.**

**Risk of damage to hearing!**

If persons are present in the vicinity of a non noise insulated machine over extended periods:

- Make sure that ear protection is being used.
- Make sure that the installation conditions (see *Installation Conditions* [→ 10]) are met.
- Switch on the machine.
- Make sure that the maximum permissible number of starts does not exceed 30 starts per hour. Those starts should be spread within the hour.
- Make sure that the operating conditions comply with the *Technical Data* [→ 28].
- After a few minutes of operation, check the oil level and top up if necessary.

As soon as the machine is operated under normal operating conditions:

- Measure the motor current and record it as reference for future maintenance and trouble-shooting work.

### 7.1 Version with Oil Return Valve

When the machine runs, oil cannot flow back to the bottom oil receiver and it accumulates in the upper chamber of the oil separator.

After 2 hours of continuous operation near ultimate pressure, in case of operation in rough vacuum, after a shorter time:

- The machine must be shut down for at least 15 min.
- The oil can run down from the upper chamber of the oil separator into the bottom chamber

### 7.2 Conveying Condensable Vapors

Water vapor within the gas flow is tolerated within certain limits. The conveyance of other vapors shall be agreed upon with Busch.

If condensable vapors are to be conveyed:

**START**



- Close the isolation valve\* and open the gas ballast valve\*\* (GB)
- Warm up the machine
- Wait 30 minutes
- Open the isolation valve\* and perform the process
- Close the isolation valve\*
- Wait 30 minutes
- Close the gas ballast valve\*\* (GB)

**END**

*\* not included in the scope of delivery*

*\*\* may be considered as optional on certain products*

## 8 Maintenance



### DANGER

**Live wires.**

**Risk of electrical shock.**

- Electrical installation work must only be executed by qualified personnel.



### WARNING



**Machines contaminated with hazardous material.**

**Risk of poisoning!**

**Risk of infection!**

If the machine is contaminated with hazardous material:

- Wear appropriate personal protective equipment.



### CAUTION

**Hot surface.**

**Risk of burns!**

- Prior to any action requiring touching the machine, let the machine cool down first.



### CAUTION

**Failing to properly maintain the machine.**

**Risk of injuries!**

**Risk of premature failure and loss of efficiency!**

- Maintenance work must only be executed by qualified personnel.
- Respect the maintenance intervals or ask your Busch representative for service.



### NOTICE

**Using inappropriate cleaners.**

**Risk of removing safety stickers and protective paint!**

- Do not use incompatible solvents to clean the machine.

- Shut down the machine and lock against inadvertent start up.
- Vent the connected lines to atmospheric pressure.

If necessary:

- Disconnect all connections.

## 8.1 Maintenance Schedule

The maintenance intervals depend very much on the individual operating conditions. The intervals given below are considered as starting values which should be shortened or extended as appropriate. Particularly harsh applications or heavy duty operation, such as high dust loads in the environment or in the process gas, other contamination or ingress of process material, can make it necessary to shorten the maintenance intervals significantly.

Maintenance work	Interval	
	Normal application	Harsh application
<ul style="list-style-type: none"> <li>Check the oil level, see <i>Oil Level Inspection</i> [→ 19].</li> </ul>	Daily	
<ul style="list-style-type: none"> <li>Check the machine for oil leaks - in case of leaks have the machine repaired (contact Busch).</li> </ul> In case of an inlet filter being installed: <ul style="list-style-type: none"> <li>Check the inlet filter cartridge, replace if necessary.</li> </ul>	Monthly	
<ul style="list-style-type: none"> <li>Change the oil*, the oil filter* (OF) and the exhaust filters (EF).</li> </ul>	Max. after 4000 hours, at the latest after 1 year	Max. after 2000 hours, at the latest after 6 months
<ul style="list-style-type: none"> <li>Clean the machine from dust and dirt.</li> </ul> In case of a gas ballast valve (GB) being installed: <ul style="list-style-type: none"> <li>Clean the gas ballast valve.</li> </ul> If the machine is equipped with an air-oil heat exchanger (AHE): <ul style="list-style-type: none"> <li>Check and/or clean the air-oil heat exchanger.</li> </ul>	Every 6 months	
<ul style="list-style-type: none"> <li>Contact Busch for an inspection. If required, overhaul the machine.</li> </ul>	Every 5 years	

\* Service interval for synthetic oil, shorten the interval when using mineral oil, contact Busch Service

## 8.2 Oil Level Inspection

- Shut down the machine.
- When the machine is stopped, wait 1 minute before checking the oil level.



- Fill up if necessary, see *Oil Filling* [→ 12].

## 8.3 Oil and Oil Filter Change

### ! NOTICE

**Use of an inappropriate oil.**

**Risk of premature failure!**

**Loss of efficiency!**

- Only use an oil type which has previously been approved and recommended by Busch.

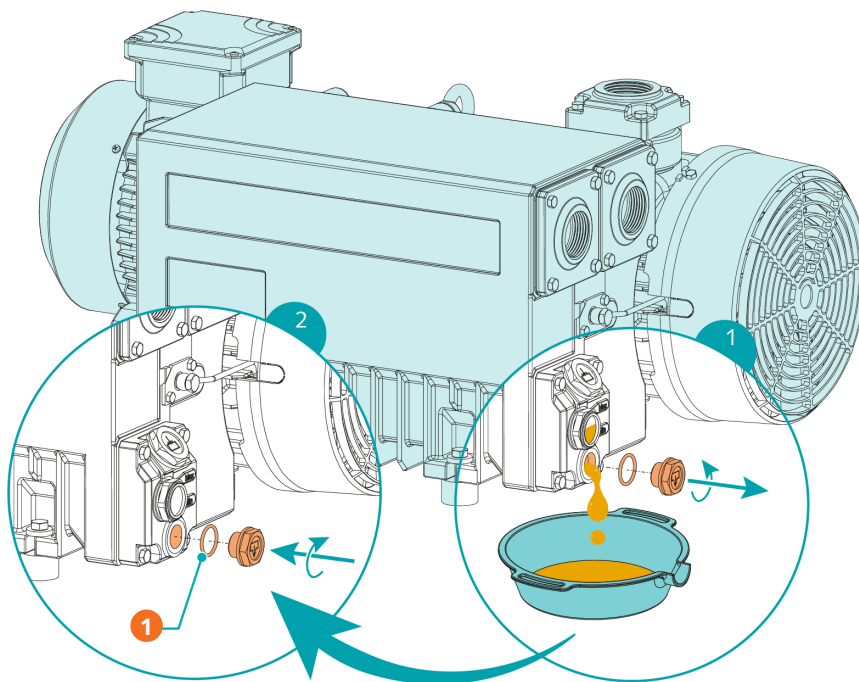

#### Description

1	1x o-ring, part no.: 0486 000 505		
---	-----------------------------------	--	--

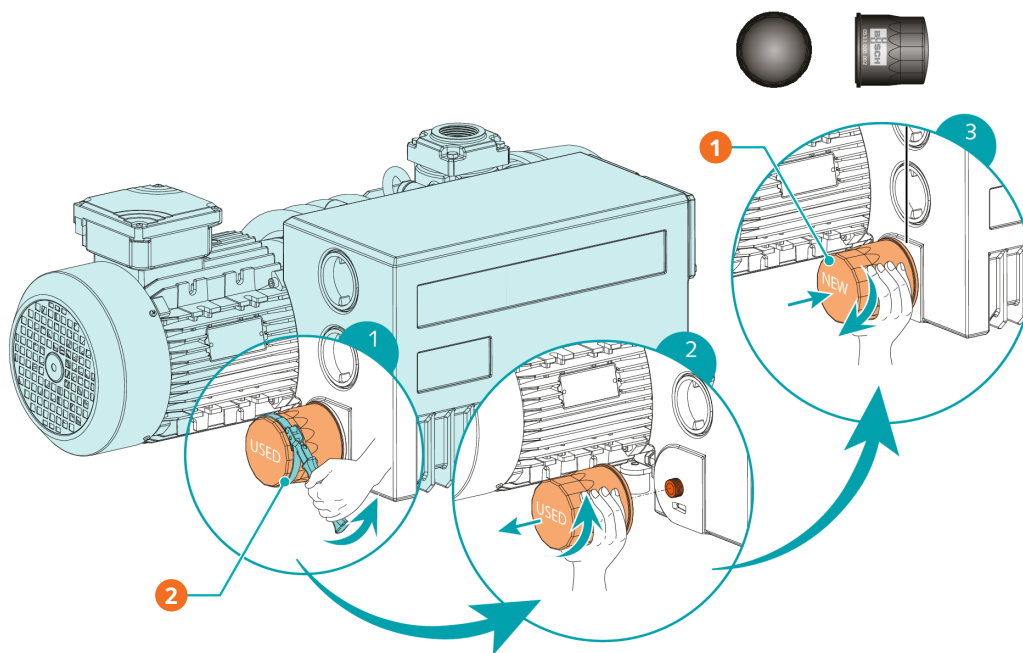

Description			
1	Busch genuine spare parts : 1x oil filter (OF), part no.: 0531 000 002	2	Oil filter wrench

For oil type and oil capacity see *Technical Data* [→ 28] and *Oil* [→ 29].

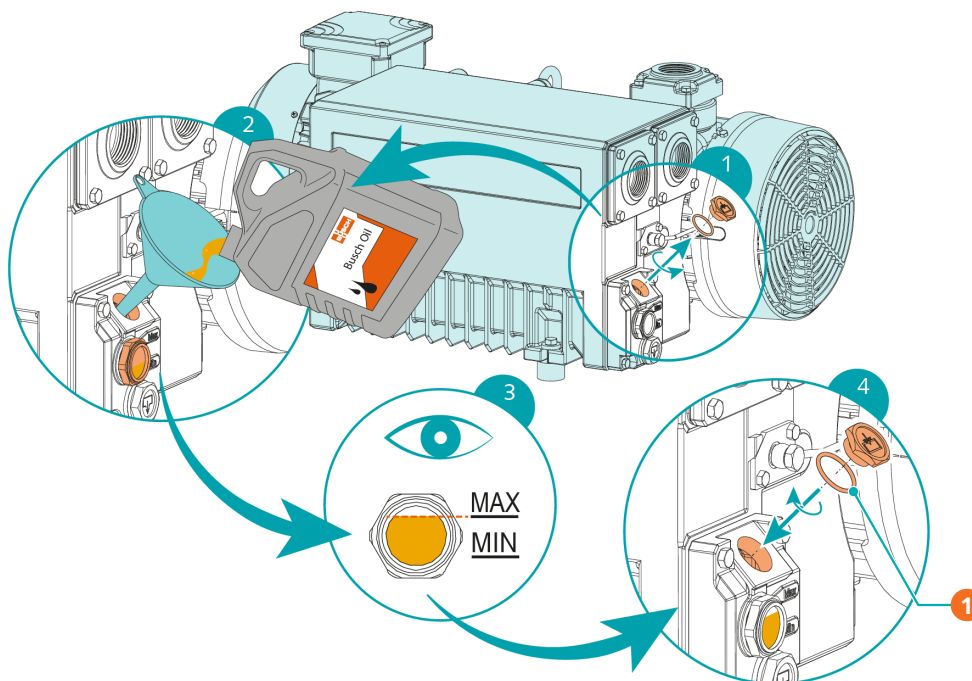

Description			
1	1x o-ring, part no.: 0486 000 590		

## 8.4 Exhaust Filter Change

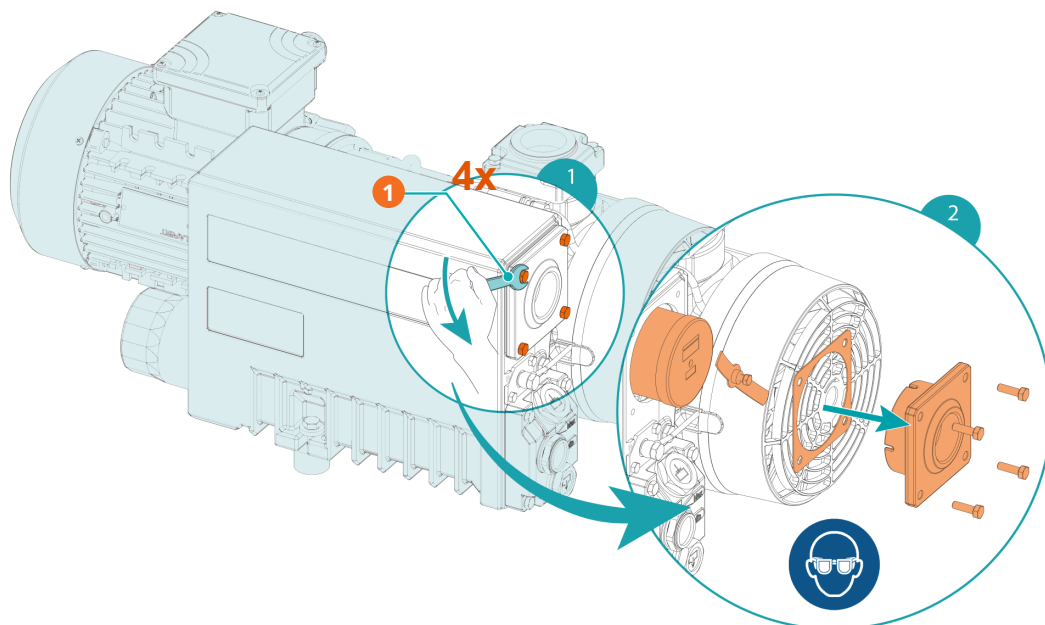

### Description

1	10 mm wrench
---	--------------

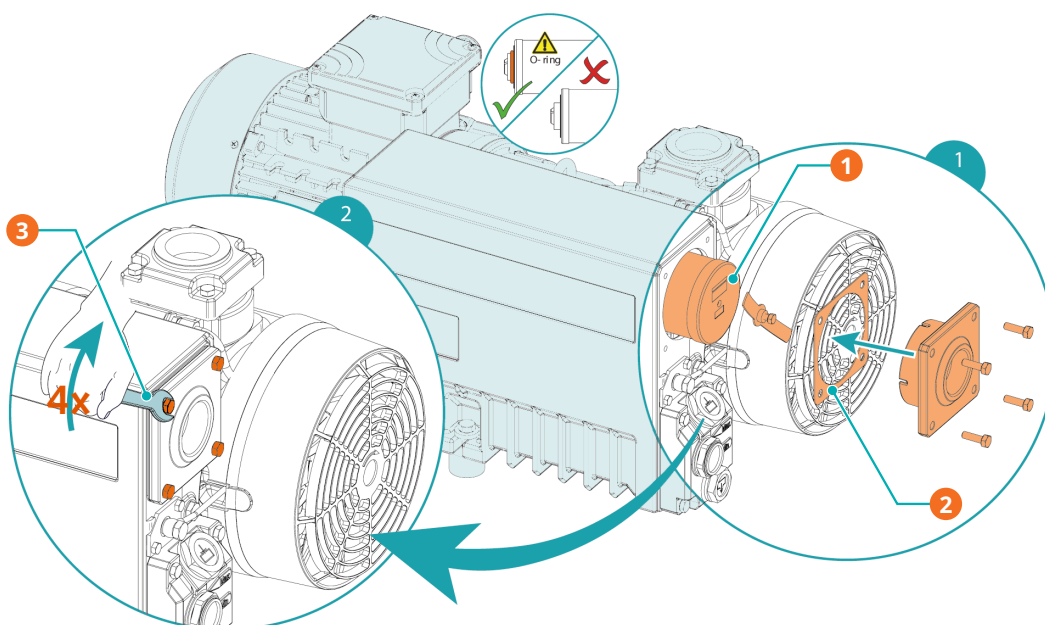

### Description

1	Busch genuine spare parts: 1x Exhaust filter (EF),, part no.: 0532 140 156	2	1x flat gasket, : part no.: 0480 000 112
3	10 mm wrench		

## 9 Overhaul



### WARNING



**Machines contaminated with hazardous material.**

**Risk of poisoning!**

**Risk of infection!**

If the machine is contaminated with hazardous material:

- Wear appropriate personal protective equipment.



### NOTICE

**Improper assembly.**

**Risk of premature failure!**

**Loss of efficiency!**

- Any dismantling of the machine that goes beyond anything that is described in this manual should be done by Busch authorized technicians.

In case of the machine having conveyed gas that was contaminated with foreign materials which are dangerous to health:

- Decontaminate the machine as much as possible and state the contamination status in a 'Declaration of Contamination'.

Busch will only accept machines that come with a completely filled in and legally binding signed 'Declaration of Contamination' (form downloadable from [www.buschvacuum.com](http://www.buschvacuum.com)).

## 10 Decommissioning



### DANGER

**Live wires.**

**Risk of electrical shock.**

- Electrical installation work must only be executed by qualified personnel.



### CAUTION

**Hot surface.**

**Risk of burns!**

- Prior to any action requiring touching the machine, let the machine cool down first.

- Shut down the machine and lock against inadvertent start up.
- Disconnect the power supply.
- Vent the connected lines to atmospheric pressure.
- Disconnect all connections.

If the machine is going to be stored:

- See *Storage* [→ 9].

### 10.1 Dismantling and Disposal

- Drain and collect the oil.
- Make sure that no oil drips onto the floor.
- Remove the exhaust filters.
- Remove the oil filter.
- Separate special waste from the machine.
- Dispose of special waste in compliance with applicable regulations.
- Dispose of the machine as scrap metal.



# 11 Spare Parts



## NOTICE

**Use of non-Busch genuine spare parts.**

**Risk of premature failure!**

**Loss of efficiency!**

- The exclusive use of Busch genuine spare parts and consumables is recommended for the correct functioning of the machine and to validate the warranty.

Spare parts kit	Description	Part no.
Service kit	Includes all the necessary parts for maintenance.	0992 101 463

If other parts are required:

- Contact your Busch representative.

# 12 Troubleshooting



## DANGER

Live wires.

Risk of electrical shock.

- Electrical installation work must only be executed by qualified personnel.



## CAUTION

Hot surface.

Risk of burns!

- Prior to any action requiring touching the machine, let the machine cool down first.

Illustration showing parts that may be involved during troubleshooting:

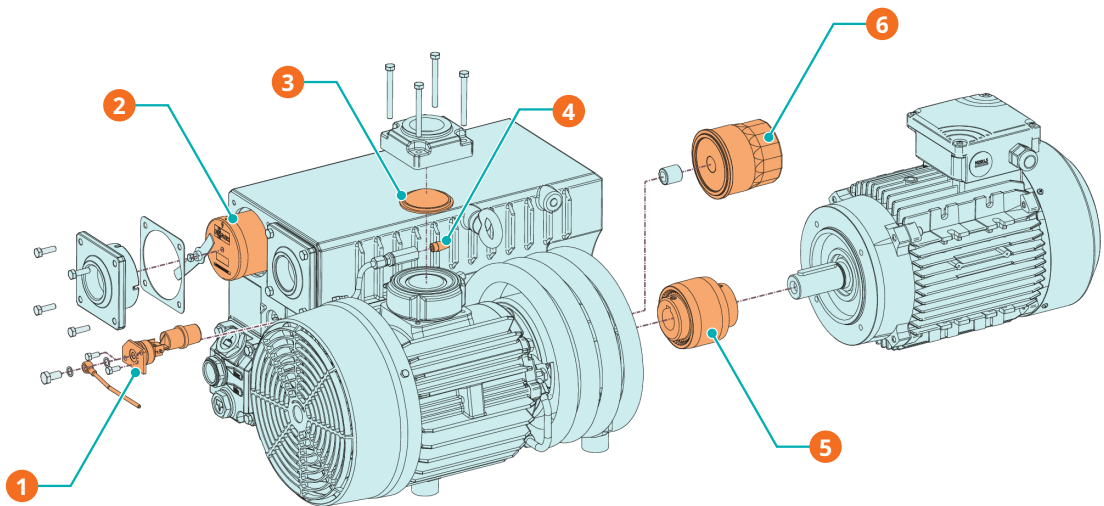

Description			
1	FV	2	EF
3	IS	4	GB
5	CPL	6	OF

Problem	Possible Cause	Remedy
The machine does not start.	The motor is not supplied with the correct voltage.	• Check the power supply.
	The motor is defective.	• Replace the motor.
	The coupling (CPL) is defective.	• Replace the coupling (CPL).

Problem	Possible Cause	Remedy
The machine does not reach the usual pressure on the suction connection.	Oil level too low.	<ul style="list-style-type: none"> <li>• Top up oil.</li> </ul>
	The inlet screen (IS) is partially clogged.	<ul style="list-style-type: none"> <li>• Clean the inlet screen (IS).</li> </ul>
	The inlet filter cartridge (optional) is partially clogged.	<ul style="list-style-type: none"> <li>• Replace the inlet filter cartridge.</li> </ul>
	Internal parts are worn or damaged.	<ul style="list-style-type: none"> <li>• Repair the machine (contact Busch).</li> </ul>
The machine runs very noisily.	Worn coupling (CPL).	<ul style="list-style-type: none"> <li>• Replace the coupling (CPL).</li> </ul>
	Stuck vanes.	<ul style="list-style-type: none"> <li>• Repair the machine (contact Busch).</li> </ul>
	Defective bearings.	<ul style="list-style-type: none"> <li>• Repair the machine (contact Busch).</li> </ul>
The machine runs too hot.	Insufficient cooling.	<ul style="list-style-type: none"> <li>• Remove dust and dirt from the machine.</li> <li>• Check the cooling fan.</li> </ul>
	Ambient temperature too high.	<ul style="list-style-type: none"> <li>• Observe the permitted ambient temperature.</li> </ul>
	Oil level too low.	<ul style="list-style-type: none"> <li>• Top up oil.</li> </ul>
	The exhaust filters (EF) are partially clogged.	<ul style="list-style-type: none"> <li>• Replace the exhaust filters (EF).</li> </ul>
The machine fumes or expels oil droplets through the gas discharge.	The exhaust filters (EF) are partially clogged.	<ul style="list-style-type: none"> <li>• Replace the exhaust filters (EF).</li> </ul>
	An exhaust filter (EF) with o-ring is not fitted properly.	<ul style="list-style-type: none"> <li>• Ensure the correct position of the exhaust filters (EF) and the o-rings.</li> </ul>
	The float valve (FV) does not work properly.	<ul style="list-style-type: none"> <li>• Check the float valve and the oil pipe for clogging. Remove the clogging.</li> </ul>
	Version with oil return valve: The machine runs for more than 2 hours without interruption.	<ul style="list-style-type: none"> <li>• Regularly shut down the machine for short periods of time (see <i>Version with Oil Return Valve</i> [→ 16]).</li> </ul>
The oil is black.	Oil change intervals are too long.	<ul style="list-style-type: none"> <li>• Flush the machine (contact Busch).</li> </ul>
	The inlet filter (optional) is defective.	<ul style="list-style-type: none"> <li>• Replace the inlet filter.</li> </ul>
	The machine runs too hot.	<ul style="list-style-type: none"> <li>• See problem "The machine runs too hot".</li> </ul>
The oil is emulsified.	The machine sucked in liquids or significant amounts of vapor.	<ul style="list-style-type: none"> <li>• Flush the machine (contact Busch).</li> <li>• Clean the filter of the gas ballast valve (GB).</li> <li>• Modify the operational mode (see <i>Conveying Condensable Vapors</i> [→ 16]).</li> </ul>

For the solution of problems not mentioned in the troubleshooting chart contact your Busch representative.

# 13 Technical Data

RA 0063 F 5K		
Nominal pumping speed (50Hz / 60Hz)	m <sup>3</sup> /h	63 / 76
Ultimate pressure (without gas ballast valve)	hPa (mbar) abs.	0.1 ... 0.5 ► see nameplate (NP)
Ultimate pressure (with gas ballast valve)	hPa (mbar) abs.	0.5 ... 1.5
Nominal motor speed (50Hz / 60Hz)	min <sup>-1</sup>	1500 / 1800
Nominal motor rating (50Hz / 60Hz)	kW	2.0 / 2.4
Power consumption at 100 mbar (50Hz / 60Hz)	kW	1.3 / 1.5
Power consumption at ultimate pressure (50Hz / 60Hz)	kW	0.7 / 0.8
Noise level (EN ISO 2151) (50Hz / 60Hz)	dB(A)	64 / 67
Water vapor tolerance max. (with gas ballast valve)	hPa (mbar) abs.	40
Water vapor capacity (with gas ballast valve)	kg / h	1.8
Operating temperature (50Hz / 60Hz)	°C	84 / 92
Ambient temperature range	°C	5 ... 40
Ambient pressure		Atmospheric pressure
Oil capacity	l	1.0
Weight approx.	kg	52

# 14 Oil

	VM 100	VSA 100	VSB 100	VSC 100
ISO-VG	100	100	100	100
Oil type	Mineral oil	Synthetic oil	Synthetic oil	Synthetic oil
Part number 1 L packaging	0831 000 060	0831 163 968	0831 168 351	0831 168 356
Part number 5 L packaging	0831 000 059	0831 163 969	0831 168 352	0831 168 357
Remark	Standard application up to 90°C	Food applications (H1); Light cycle operation	Food applications (H1); Suitable for continuous operation	Suitable for Harsh application

In case of unfavorable ambient temperature, other oil viscosities may be used. Please consult your Busch representative for more details.

To know which oil has been filled in the machine, please refer to the nameplate (NP).

# 15 EU Declaration of Conformity

This Declaration of Conformity and the CE-markings affixed to the nameplate are valid for the machine within the Busch scope of delivery. This Declaration of Conformity is issued under the sole responsibility of the manufacturer.

When this machine is integrated into a superordinate machinery the manufacturer of the superordinate machinery (this can be the operating company, too) must conduct the conformity assessment process for the superordinate machine or plant, issue the Declaration of Conformity for it and affix the CE-marking.

The manufacturer

**Busch Produktions GmbH**  
**Schauinslandstr. 1**  
**DE-79689 Maulburg**

declares that the machine: R5 RA 0063 F 5K

fulfill(s) all the relevant provisions from EU directives:

- 'Machinery' 2006/42/EC
- 'Electromagnetic Compatibility' (EMS) 2014/30/EU
- 'RoHS' 2011/65/EU Restriction of the use of certain hazardous substances in electrical and electronic equipment (incl. all related applicable amendments)

and comply(-ies) with the following designated standards that have been used to fulfill those provisions:

Standards	Title of the Standard
EN ISO 12100 : 2010	Safety of machinery - Basic concepts, general principles of design
EN ISO 13857 : 2019	Safety of machinery - Safety distances to prevent hazard zones being reached by the upper and lower limbs
EN 1012-2 : 1996 + A1 : 2009	Vacuum pumps - Safety requirements - Part 2
EN ISO 2151 : 2008	Acoustics - Noise test code for compressors and vacuum pumps - Engineering method (grade 2)
EN 60204-1 : 2018	Safety of machinery - Electrical equipment of machines - Part 1: General requirements
EN IEC 61000-6-2 : 2019	Electromagnetic compatibility (EMC) - Generic standards. Immunity for industrial environments
EN IEC 61000-6-4 : 2019	Electromagnetic compatibility (EMC) - Generic standards. Emission standard for industrial environments

Legal person authorized to compile the technical file and authorized representative in the EU (if the manufacturer is not located in the EU):

Busch Dienste GmbH  
 Schauinslandstr. 1  
 DE-79689 Maulburg

Maulburg, 18.08.2021



**Dr. Martin Gutmann**  
**General Manager**  
**Busch Produktions GmbH**

# 16 UK Declaration of Conformity

This Declaration of Conformity and the UKCA-markings affixed to the nameplate are valid for the machine within the Busch scope of delivery. This Declaration of Conformity is issued under the sole responsibility of the manufacturer.

When this machine is integrated into a superordinate machinery the manufacturer of the superordinate machinery (this can be the operating company, too) must conduct the conformity assessment process for the superordinate machine or plant, issue the Declaration of Conformity for it and affix the UKCA-marking.

The manufacturer

**Busch Produktions GmbH**  
**Schauinslandstr. 1**  
**DE-79689 Maulburg**

declares that the machine: R5 RA 0063 F 5K

fulfill(s) all the relevant provisions from UK legislations:

- Supply of Machinery (Safety) Regulations 2008
- Electromagnetic Compatibility Regulations 2016
- Restriction of the use of certain hazardous substances in Electrical and Electronic Equipment Regulations 2021

and comply(-ies) with the following designated standards that have been used to fulfill those provisions:

Standards	Title of the Standard
EN ISO 12100 : 2010	Safety of machinery - Basic concepts, general principles of design
EN ISO 13857 : 2019	Safety of machinery - Safety distances to prevent hazard zones being reached by the upper and lower limbs
EN 1012-2 : 1996 + A1 : 2009	Vacuum pumps - Safety requirements - Part 2
EN ISO 2151 : 2008	Acoustics - Noise test code for compressors and vacuum pumps - Engineering method (grade 2)
EN 60204-1 : 2018	Safety of machinery - Electrical equipment of machines - Part 1: General requirements
EN IEC 61000-6-2 : 2019	Electromagnetic compatibility (EMC) - Generic standards. Immunity for industrial environments
EN IEC 61000-6-4 : 2019	Electromagnetic compatibility (EMC) - Generic standards. Emission standard for industrial environments

Legal person authorized to compile the technical file and importer in the UK (if the manufacturer is not located in the UK):

Busch (UK) Ltd  
 30 Hortonwood  
 Telford - UK

Maulburg, 18.08.2021



**Dr. Martin Gutmann**  
**General Manager**  
**Busch Produktions GmbH**

# Busch

## Vacuum Solutions

With a network of over 60 companies in more than 40 countries and agencies worldwide, Busch has a global presence. In every country, highly competent local personnel delivers custom-tailored support backed by a global network of expertise. Wherever you are. Whatever your business. We are there for you.

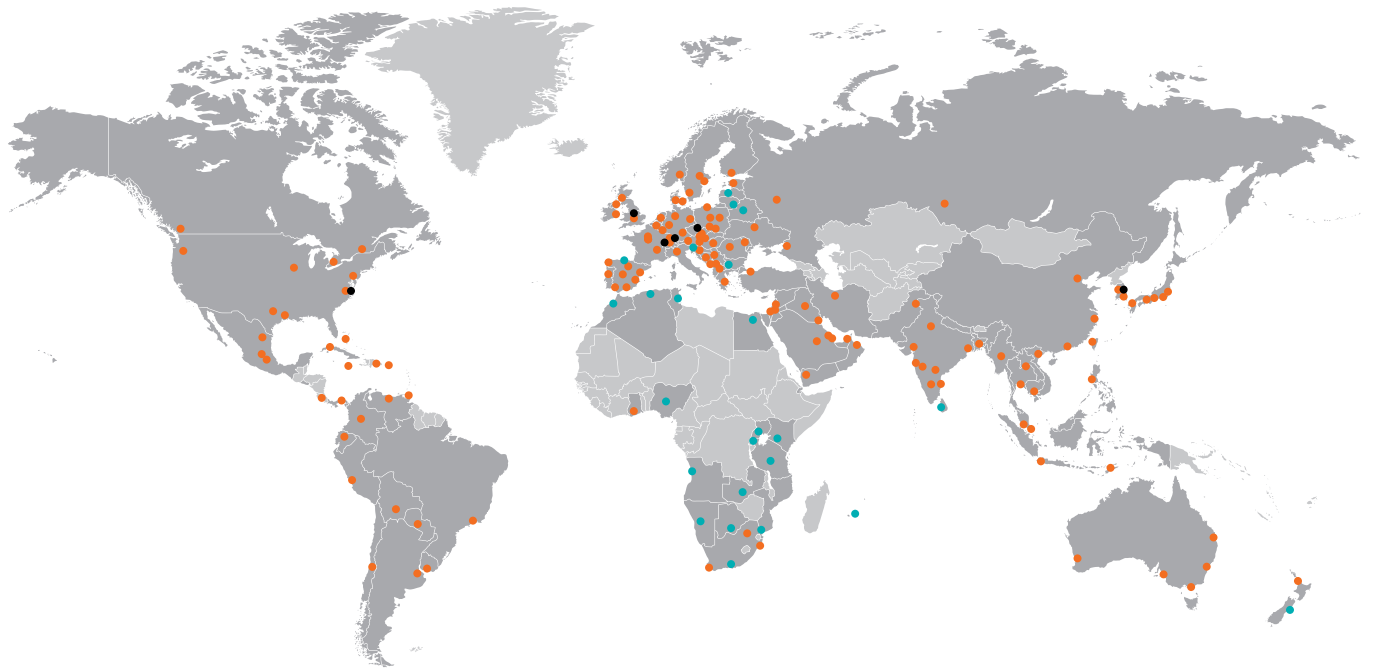

● Local representatives and distributors ● Busch companies and Busch employees ● Busch production site

[www.buschvacuum.com](http://www.buschvacuum.com)