

COBRA BA 0100 C

Dry screw vacuum pump



VACUUM SOLUTIONS



High performance

Advanced screw design, bell-shaped construction, patented self-balancing screws, excellent running qualities, perfectly suited for semiconductor and analytical applications, sterilization, freeze-drying, furnaces, thin film coating and gas recovery

Efficient

Low cost of ownership, minimal maintenance, long service intervals, high uptime, efficient air cooling

Compact

Fit-in-place design, directly mounted canned motor

Accessories

- Seal and dilution gas system for pumping vapors and condensable gases

COBRA BA 0100 C

Dry screw vacuum pump



Dimensional drawing

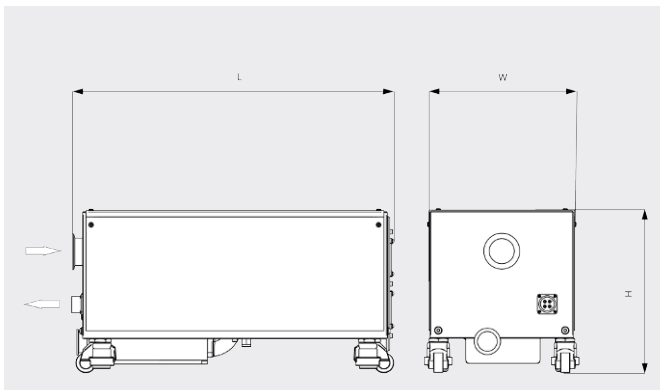

Pumping speed

Air at 20°C. Tolerance: ± 10%

— 50 Hz 60 Hz

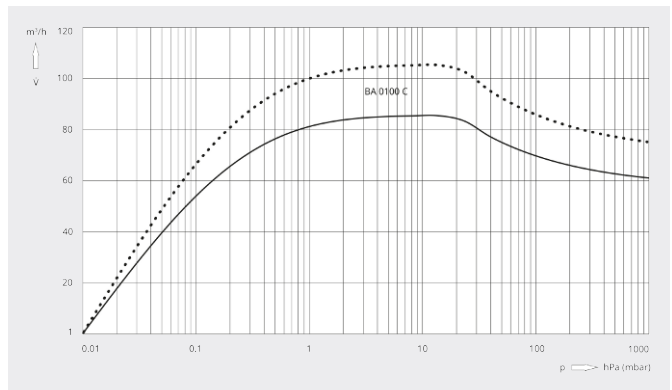

COBRA BA 0100 C	
Article number	1361570759
Nominal pumping speed	85 / 105 m³/h (50 / 60 Hz)
Ultimate pressure	0.01 (50 / 60 Hz)
Nominal motor rating	1.5 / 1.8 kW (50 / 60 Hz)
Power consumption at ultimate pressure	1.1 / 1.25 kW (50 / 60 Hz)
Nominal motor speed	3000 / 3600 min ⁻¹ (50 / 60 Hz)
Noise level (ISO 2151)	58 dB(A) (50 / 60 Hz)
Nitrogen consumption	0 – 50 l/min
Weight approx.	120 kg
Dimensions (L x W x H)	634 x 304 x 338 mm
Gas inlet / outlet	DN 50 KF / DN 40 KF
Additional information	<ul style="list-style-type: none"> • Air cooling • Horizontal stainless steel silencer • Castor wheels with integrated silent blocks • Prefilled with PFPE oil

DO YOU WANT TO KNOW MORE?

Get in touch with us directly!



CONTACT FORM