

# DOLPHIN LR 0700/1190 A

Liquid ring vacuum pumps



VACUUM SOLUTIONS



## Robust

Proven technology, reliable operation, extremely high vapor and particle tolerance, specially designed for challenging environments like mining, power plants, sugar production, pulp and paper industry, steel production etc.

## High performance

High-capacity, high pumping speeds

## Flexible

Modular design, choice of cast iron (EN-GJL-200) housing with ductile cast iron impeller or all 304 grade, or 316L grade corrosion-free stainless steel material, operating fluids other than water possible, operation as compressor possible

### Accessories

- Motorized pumpsets, with gearbox or V-belt drive system, mounted on sturdy steel base frames
- Partial or total recirculation systems
- Cavitation protection
- Gas ejector
- Non-return valves
- Vacuum relief valves

# DOLPHIN LR 0700/1190 A

Liquid ring vacuum pumps



VACUUM SOLUTIONS

Dimensional drawing

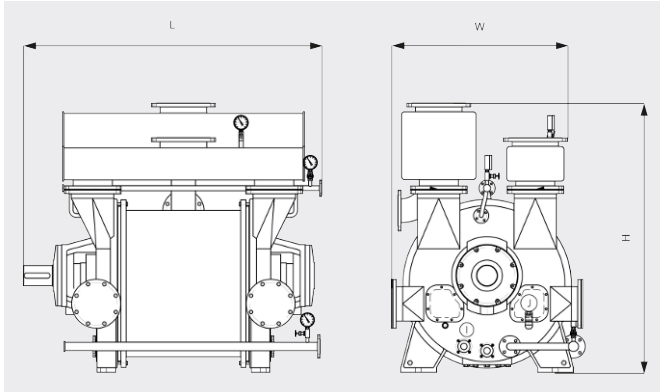

Pumping speed

Air at 20°C. Tolerance: ± 10%

— 50 Hz ..... 60 Hz

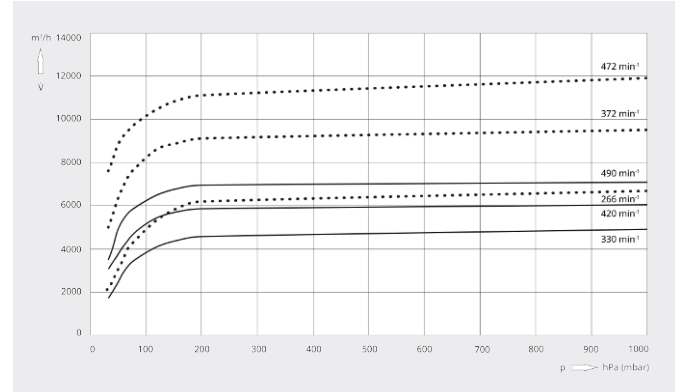

	DOLPHIN LR 0700 A	DOLPHIN LR 1190 A
Nominal pumping speed	4920 – 7000 m <sup>3</sup> /h	6700 – 11900 m <sup>3</sup> /h
Ultimate pressure	33 hPa (mbar)	33 hPa (mbar)
Nominal motor rating	110 – 200 kW	160 – 355 kW
Nominal motor speed	330 – 490 min <sup>-1</sup>	266 – 472 min <sup>-1</sup>
Noise level (ISO 2151)	< 85 dB(A)	< 85 dB(A)
Weight approx.	3750 kg	5390 kg
Dimensions (L x W x H)	2020 x 1350 x 1865 mm	2258 x 1550 x 2160 mm
Gas inlet / outlet	DN 300 PN 10 / DN 300 PN 10	DN 350 PN 10 / DN 350 PN 10

DO YOU WANT TO KNOW MORE?

Get in touch with us directly!



CONTACT FORM