

R5 RA 1000/1600 A PLUS

Oil-lubricated rotary vane vacuum pumps

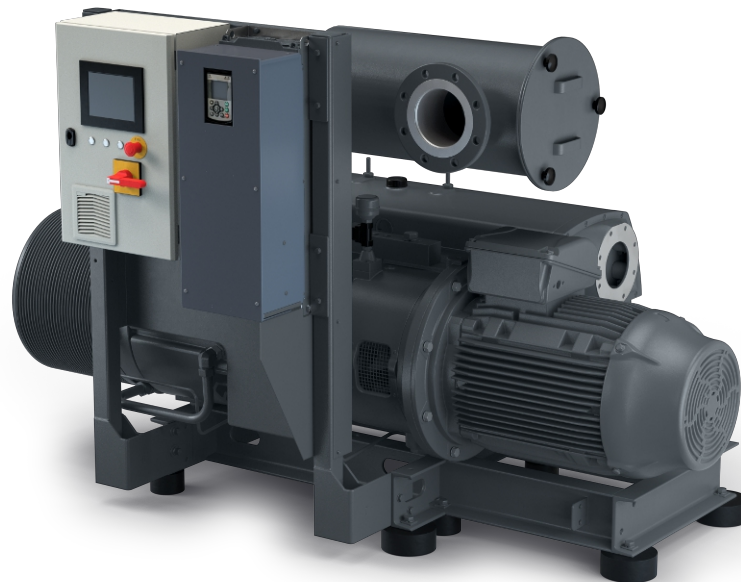

VACUUM SOLUTIONS



Control and monitoring

Ready for Industry 4.0 providing remote control, condition monitoring and communication protocols

Cost savings

Reduced energy consumption and minimized operating costs

Proven technology

Reliable operation thanks to R5 rotary vane vacuum technology

R5 RA 1000/1600 A PLUS

Oil-lubricated rotary vane vacuum pumps



Dimensional drawing

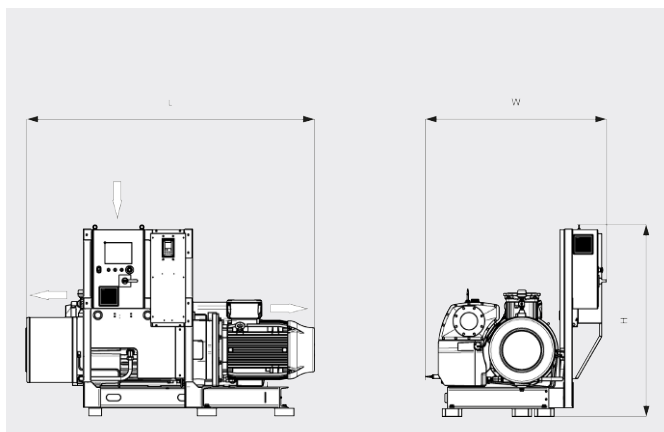

Pumping speed

Air at 20°C. Tolerance: ± 10%

— Min. speed Max. speed

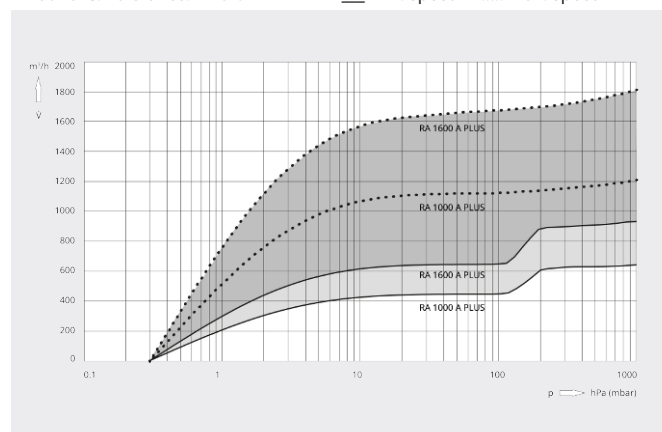

	R5 RA 1000 A PLUS	R5 RA 1600 A PLUS
Nominal pumping speed	440 – 1200 m ³ /h	640 – 1800 m ³ /h
Ultimate pressure	0.3 hPa (mbar)	0.3 hPa (mbar)
Nominal motor rating	30 kW	37 kW
Nominal motor speed	500 – 1200 min ⁻¹	500 – 1200 min ⁻¹
Power consumption at 100 mbar	8.6 – 22.3 kW	12.8 – 35.9 kW
Power consumption at ultimate pressure	5.4 – 12.5 kW	6.9 – 19.0 kW
Noise level (ISO 2151)	65 – 79 dB(A)	69 – 83 dB(A)
Oil capacity	30 l	30 l
Weight approx.	1230 kg	1580 kg
Dimensions (L x W x H)	1964 x 1422 x 1451 mm	2198 x 1422 x 1451 mm
Gas inlet / outlet	DN 150 / DN 125	DN 150 / DN 125

DO YOU WANT TO KNOW MORE?

Get in touch with us directly!



CONTACT FORM