

# MINK MV 1202 B

Dry claw vacuum pump



VACUUM SOLUTIONS



## Quiet

Low noise level due to a state-of-the-art acoustic design, can be installed at workstations

## Efficient

Latest claw vacuum technology, low energy consumption, minimized operating costs, nearly maintenance-free, effective air cooling

## Compact

Small footprint

Accessories, spare parts and options

• Aqua version

• IoT kit

• ATEX Category 3

# MINK MV 1202 B

Dry claw vacuum pump



VACUUM SOLUTIONS

Dimensional drawing

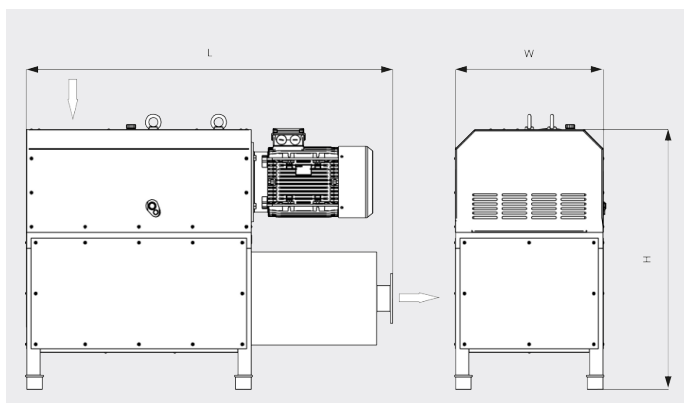

Pumping speed

Air at 20°C. Tolerance: ± 10%

50 Hz ..... 60 Hz

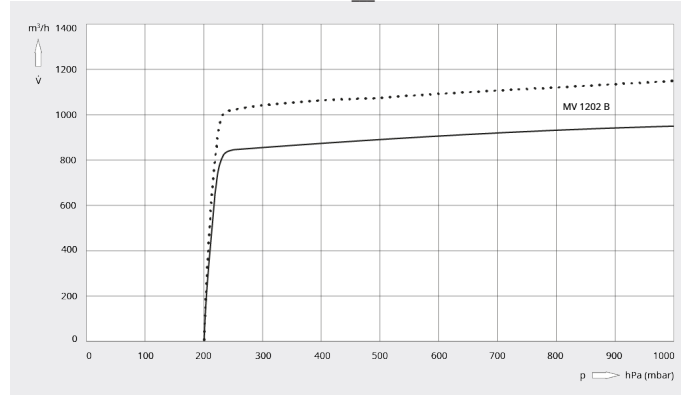

MINK MV 1202 B	
Nominal pumping speed	950 / 1150 m <sup>3</sup> /h (50 / 60 Hz)
Ultimate pressure	200 hPa (mbar) (50 / 60 Hz)
Nominal motor rating	18.5 / 22.0 kW (50 / 60 Hz)
Nominal motor speed	3000 / 3600 min <sup>-1</sup> (50 / 60 Hz)
Noise level (ISO 2151)	79 / 82 dB(A) (50 / 60 Hz)
Weight approx.	900 kg
Dimensions (L x W x H)	1620 x 670 x 1210 mm
Gas inlet / outlet	DN 100, PN 10/16 / DN 100, PN 10/16

## DO YOU WANT TO KNOW MORE?

Get in touch with us directly!  
[info@busch.ca](mailto:info@busch.ca) or +1 800 363 6360



CONTACT FORM



CALL NOW