

FOSSA FO 0015 A

Scroll vacuum pumps



VACUUM SOLUTIONS



Robust

Specially designed for analytical and scientific applications, for example leak detection, single-sided scroll design, dry compression, gas-tight, lifetime-lubricated bearings, minimal maintenance

Easy servicing

No special tools necessary, modular design for rapid exchange of stages

Quiet

Low noise and vibration levels, can be installed at workstations

Accessories, spare parts and options

- Inlet filter, FIL 0080
- Exhaust filter and silencer
- Gas-ballast valve
- Gas-ballast adapter, dilution kit
- Four castor wheels
- Tip seal replacement kit

FOSSA FO 0015 A

Scroll vacuum pumps



VACUUM SOLUTIONS

Dimensional drawing

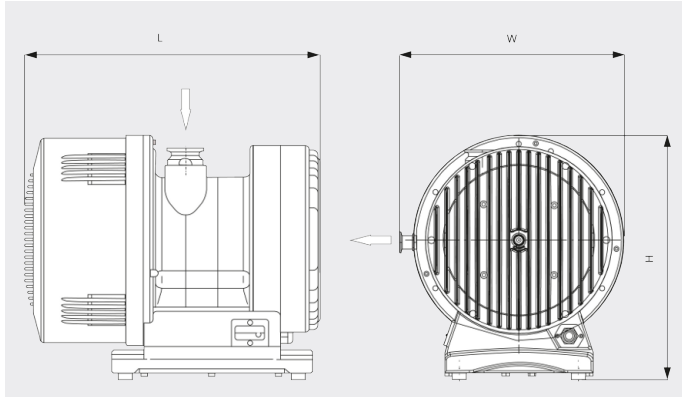

Pumping speed

Air at 20°C. Tolerance: ± 10%

— 50 Hz 60 Hz

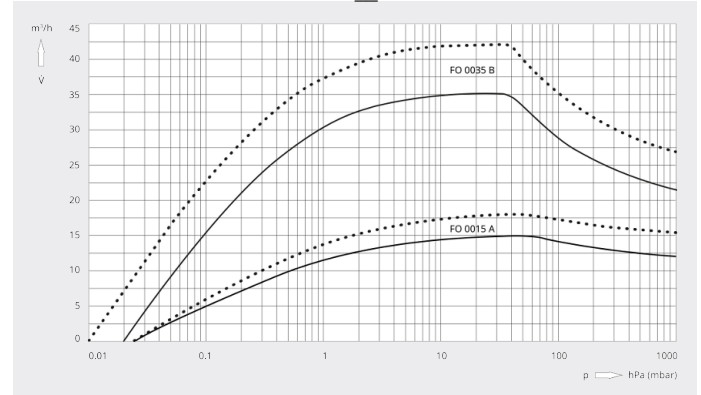

	FOSSA FO 0015 A	FOSSA FO 0015 A	FOSSA FO 0015 A	FOSSA FO 0015 A
Pumping speed	15 / 18 m³/h (50 / 60 Hz)	15 / 18 m³/h (50 / 60 Hz)	15 / 18 m³/h (50 / 60 Hz)	15 / 18 m³/h (50 / 60 Hz)
Pumping speed	250 / 300 l/min (50 / 60 Hz)	250 / 300 l/min (50 / 60 Hz)	250 / 300 l/min (50 / 60 Hz)	250 / 300 l/min (50 / 60 Hz)
Ultimate total pressure (gas-ballast valve closed)	0.025 hPa (mbar)	0.025 hPa (mbar)	0.025 hPa (mbar)	0.025 hPa (mbar)
Ultimate total pressure (gas-ballast valve open)	0.09 hPa (mbar)	0.09 hPa (mbar)	0.09 hPa (mbar)	0.09 hPa (mbar)
Max. continuous inlet pressure	1000 hPa (mbar)	1000 hPa (mbar)	1000 hPa (mbar)	1000 hPa (mbar)
Max. back pressure	500 hPa (mbar) rel.	500 hPa (mbar) rel.	500 hPa (mbar) rel.	500 hPa (mbar) rel.
Water vapor capacity (gas-ballast valve open)	300 g/h	300 g/h	300 g/h	300 g/h
Leakage rate (helium)	< 1 · 10 ⁻⁶ mbar · l/s	< 1 · 10 ⁻⁶ mbar · l/s	< 1 · 10 ⁻⁶ mbar · l/s	< 1 · 10 ⁻⁶ mbar · l/s
Nominal motor rating	0.4 kW	0.4 kW	0.4 kW	0.4 kW
Operating voltage	100 – 240 V (50 / 60 Hz)	190 – 220 V (50 / 60 Hz)	100 – 115 V (50 / 60 Hz)	200 – 240 V (50 / 60 Hz)
Motor phase	Single-phase	Three-phase	Single-phase	Single-phase
Ambient temperature	5 – 40 °C	5 – 40 °C	5 – 40 °C	5 – 40 °C

FOSSA FO 0015 A

Scroll vacuum pumps



VACUUM SOLUTIONS

	FOSSA FO 0015 A	FOSSA FO 0015 A	FOSSA FO 0015 A	FOSSA FO 0015 A
Vibration level at inlet (ISO 10816-1)	Class 1B, < 1.5 mm · s ⁻¹	Class 1B, < 1.5 mm · s ⁻¹	Class 1B, < 1.5 mm · s ⁻¹	Class 1B, < 1.5 mm · s ⁻¹
Noise level (ISO 2151)	42 dB(A) (idle mode) / 59 dB(A) (max.)	42 dB(A) (idle mode) / 59 dB(A) (max.)	42 dB(A) (idle mode) / 59 dB(A) (max.)	42 dB(A) (idle mode) / 59 dB(A) (max.)
Weight approx.	48 kg	48 kg	48 kg	48 kg
Dimensions (L x W x H)	450 x 338 x 369 mm	450 x 338 x 369 mm	450 x 338 x 369 mm	450 x 338 x 369 mm
Gas inlet / outlet	DN 40 ISO-KF / DN 16 ISO-KF	DN 40 ISO-KF / DN 16 ISO-KF	DN 40 ISO-KF / DN 16 ISO-KF	DN 40 ISO-KF / DN 16 ISO-KF
Emissions and immunity	EN 61236-1:2013 as a class A device	EN 61236-1:2013 as a class A device	EN 61236-1:2013 as a class A device	EN 61236-1:2013 as a class A device
Safety	EN/IEC 61010 third edition certified	EN/IEC 61010 third edition certified	EN/IEC 61010 third edition certified	EN/IEC 61010 third edition certified
Additional information	<ul style="list-style-type: none"> • Integrated frequency converter • IEC connector + M/A IP40 switch • Female Sub-D 9-pin communication port • Certification ATEX II 3G Ex Ex h IIB T4 Gc X (inside) 	<ul style="list-style-type: none"> • IP44 cable gland • Certification ATEX II 3G Ex Ex h IIB T4 Gc X (inside) 	<ul style="list-style-type: none"> • IEC connector + M/A IP40 switch • Certification ATEX II 3G Ex Ex h IIB T4 Gc X (inside) 	<ul style="list-style-type: none"> • IEC connector + M/A IP40 switch • Certification ATEX II 3G Ex Ex h IIB T4 Gc X (inside)

DO YOU WANT TO KNOW MORE?

Get in touch with us directly!
info@busch.ca or +1 800 363 6360



CONTACT FORM



CALL NOW