

# DOLPHIN LA 3809/5109 A

Liquid ring vacuum pumps



VACUUM SOLUTIONS



## Robust

Proven technology, durable single-stage construction

## Reliable

Extremely high vapor and particle tolerance

## Flexible

Wide range of construction materials, including cast iron (EN-GJL-200), many grades of stainless steel and even titanium, ATEX-certified version available (Cat 1(i)/2(o) IIC T5), different operating fluids possible, operation as compressor possible

Accessories, spare parts and options

- Partial or total recirculation systems
- Liquid separator
- Cavitation protection
- Heat exchanger
- Gas ejector
- Wide selection of motors
- Non-return valves
- Vacuum relief valves

# DOLPHIN LA 3809/5109 A

Liquid ring vacuum pumps



VACUUM SOLUTIONS

Dimensional drawing

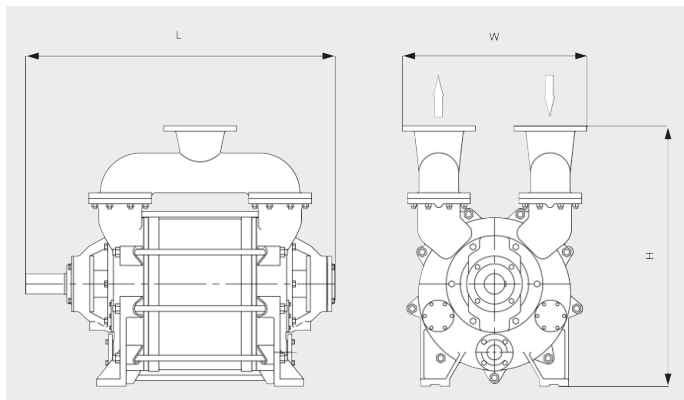

Pumping speed

Air at 20°C. Tolerance: ± 10%

— 50 Hz ..... 60 Hz

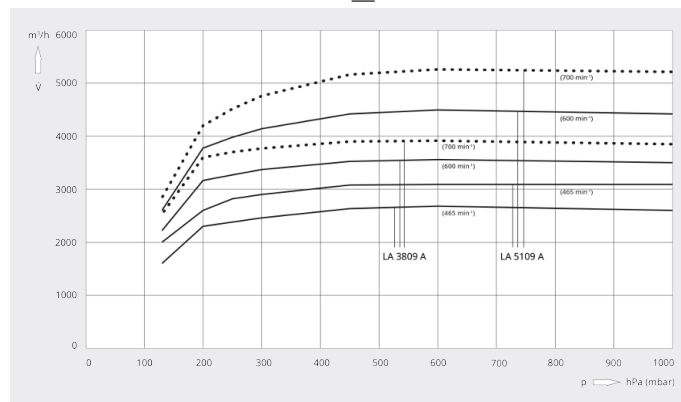

	DOLPHIN LA 3809 A	DOLPHIN LA 5109 A
<b>Nominal pumping speed</b>	2600 – 3600 / 3400 – 3800 m³/h (50 / 60 Hz)	3600 – 4700 / 4400 – 5100 m³/h (50 / 60 Hz)
<b>Ultimate pressure</b>	130 hPa (mbar)	130 hPa (mbar)
<b>Nominal motor rating</b>	75 – 110 / 90 – 132 kW	90 – 132 / 110 – 150 kW
<b>Nominal motor speed</b>	465 – 650 / 600 – 700 min <sup>-1</sup> (50 / 60 Hz)	465 – 650 / 600 – 700 min <sup>-1</sup> (50 / 60 Hz)
<b>Noise level (ISO 2151)</b>	85 dB(A)	85 dB(A)
<b>Weight approx.</b>	2030 kg	2150 kg
<b>Dimensions (L x W x H)</b>	1665 x 800 x 1400 mm	1790 x 800 x 1400 mm
<b>Gas inlet / outlet</b>	DN 250 PN 10 / DN 250 PN 10	DN 250 PN 10 / DN 250 PN 10

DO YOU WANT TO KNOW MORE?

Get in touch with us directly!  
[info@busch.ca](mailto:info@busch.ca) or +1 800 363 6360



CONTACT FORM



CALL NOW