

DOLPHIN LA 3809/5109 A

Liquid ring vacuum pumps



VACUUM SOLUTIONS



Robust

Proven technology, durable single-stage construction

Reliable

Extremely high vapor and particle tolerance

Flexible

Wide range of construction materials, including cast iron (EN-GJL-200), many grades of stainless steel and even titanium, ATEX-certified version available (Cat 1(i)/2(o) IIC T5), different operating fluids possible, operation as compressor possible

Accessories, spare parts and options

- Partial or total recirculation systems
- Liquid separator
- Cavitation protection
- Heat exchanger
- Gas ejector
- Wide selection of motors
- Non-return valves
- Vacuum relief valves

DOLPHIN LA 3809/5109 A

Liquid ring vacuum pumps



VACUUM SOLUTIONS

Dimensional drawing

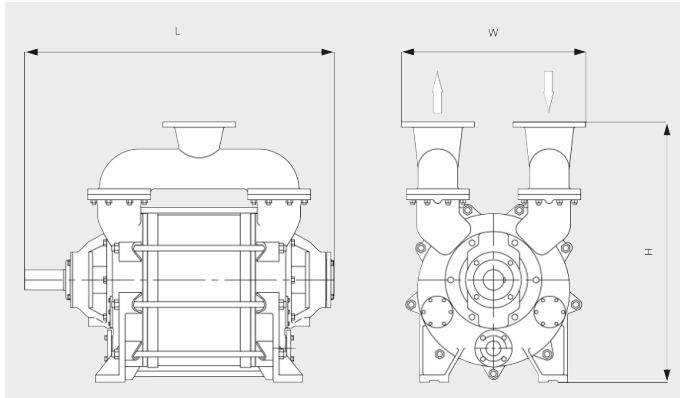

Pumping speed

Air at 20°C. Tolerance: ± 10%

— 50 Hz 60 Hz

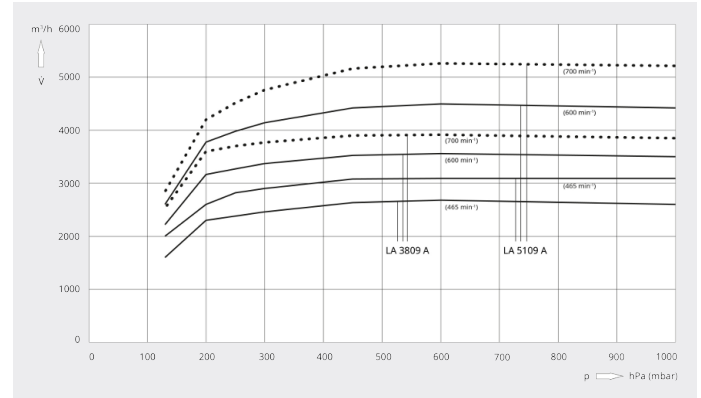

| | DOLPHIN LA 3809 A | DOLPHIN LA 5109 A |
|-------------------------------|--|--|
| Nominal pumping speed | 2600 – 3600 – 3400 – 3800 m³/h (50 / 60 Hz) | 3600 – 4700 – 4400 – 5100 m³/h (50 / 60 Hz) |
| Ultimate pressure | 130 hPa (mbar) | 130 hPa (mbar) |
| Nominal motor rating | 75 – 110 – 90 – 132 kW | 90 – 132 – 110 – 150 kW |
| Nominal motor speed | 465 – 650 – 600 – 700 min ⁻¹ (50 / 60 Hz) | 465 – 650 – 600 – 700 min ⁻¹ (50 / 60 Hz) |
| Noise level (ISO 2151) | 85 dB(A) | 85 dB(A) |
| Weight approx. | 2030 kg | 2150 kg |
| Dimensions (L x W x H) | 1665 x 800 x 1400 mm | 1790 x 800 x 1400 mm |
| Gas inlet / outlet | DN 250 PN 10 / DN 250 PN 10 | DN 250 PN 10 / DN 250 PN 10 |

DOLPHIN LA 3809/5109 A

Liquid ring vacuum pumps



VACUUM SOLUTIONS

| | DOLPHIN LA 3809 A | DOLPHIN LA 5109 A |
|------------------------|---------------------------|---------------------------|
| Nominal pumping speed | 2304.0 ACFM | 3096.0 ACFM |
| Ultimate pressure | 100 TORR | 100 TORR |
| Nominal motor rating | 200.0 HP | 200.0 HP |
| Nominal motor speed | 700 RPM | 700 RPM |
| Noise level (ISO 2151) | 85 dB(A) | 85 dB(A) |
| Weight approx. | 4299 Lbs. | 4519 Lbs. |
| Dimensions (L x W x H) | 65.6 x 37.5 x 55.1 inches | 70.5 x 37.5 x 55.1 inches |
| Gas inlet / outlet | 10" / 10" | 10" / 10" |

DO YOU WANT TO KNOW MORE?

Get in touch with us directly!
info@busch.ca or +1 800 363 6360



CONTACT FORM



CALL NOW