

DOLPHIN LB 0526/0726 A

Liquid ring vacuum pumps



VACUUM SOLUTIONS



Robust

Proven technology, durable two-stage construction

Reliable

Extremely high vapor and particle tolerance

Flexible

Wide range of construction materials, including cast iron (EN-GJL-200), many grades of stainless steel and even titanium, ATEX-certified version available (Cat 1(i)/2(o) IIC T5), operating fluids other than water possible, operation as compressor possible

Accessories, spare parts and options

- Partial or total recirculation systems
- Liquid separator
- Cavitation protection
- Heat exchanger
- Gas ejector
- Wide selection of motors
- Non-return valves
- Vacuum relief valves

DOLPHIN LB 0526/0726 A

Liquid ring vacuum pumps



VACUUM SOLUTIONS

Dimensional drawing

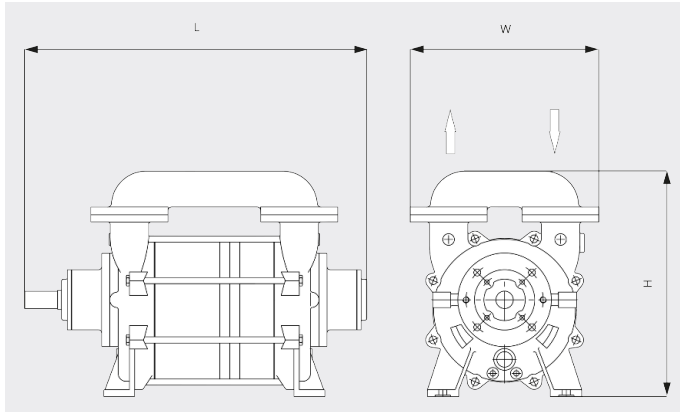

Pumping speed

Air at 20°C. Tolerance: ± 10%

— 50 Hz 60 Hz

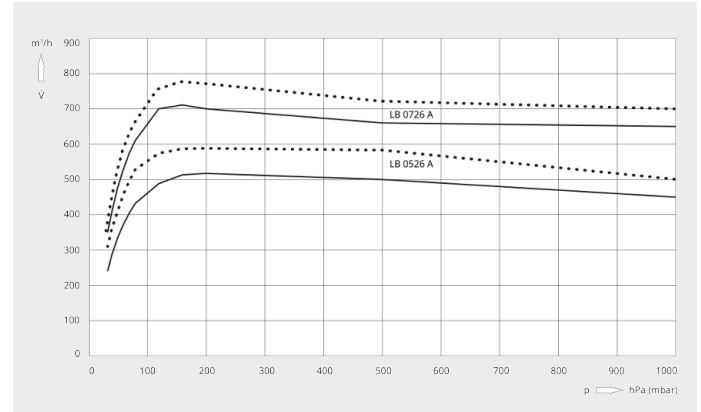

	DOLPHIN LB 0526 A	DOLPHIN LB 0726 A
Nominal pumping speed	520 / 580 m³/h (50 / 60 Hz)	720 / 770 m³/h (50 / 60 Hz)
Ultimate pressure	33 hPa (mbar) (50 / 60 Hz)	33 hPa (mbar) (50 / 60 Hz)
Max. overpressure	2 bar(g) (50 / 60 Hz)	2 bar(g) (50 / 60 Hz)
Nominal motor rating	18.5 / 22 – 30 kW (50 / 60 Hz)	22 / 30 – 37 kW (50 / 60 Hz)
Nominal motor speed	1150 / 1450 – 1750 min ⁻¹ (50 / 60 Hz)	1150 / 1450 – 1750 min ⁻¹ (50 / 60 Hz)
Noise level (ISO 2151)	74 / 75 dB(A) (50 / 60 Hz)	74 / 75 dB(A) (50 / 60 Hz)
Weight approx.	264 kg	278 kg
Dimensions (L x W x H)	(886 – 1046) x 400 x 470 mm	(1006 – 1166) x 400 x 470 mm
Gas inlet / outlet	DN 80 PN 10 / DN 80 PN 10	DN 80 PN 10 / DN 80 PN 10

DOLPHIN LB 0526/0726 A

Liquid ring vacuum pumps



VACUUM SOLUTIONS

	DOLPHIN LB 0526 A	DOLPHIN LB 0726 A
Nominal pumping speed	341.0 ACFM	453.0 ACFM
Ultimate pressure	25 TORR	25 TORR
Nominal motor rating	40.0 HP	50.0 HP
Nominal motor speed	1750 RPM	1750 RPM
Noise level (ISO 2151)	75 dB(A)	75 dB(A)
Weight approx.	581 Lbs.	613 Lbs.
Dimensions (L x W x H)	41.2 x 15.8 x 23.4 inches	45.9 x 15.8 x 23.4 inches
Gas inlet / outlet	3" ANSI 150 lb / 3" ANSI 150 lb	3" ANSI 150 lb / 3" ANSI 150 lb

DO YOU WANT TO KNOW MORE?

Get in touch with us directly!
info@busch.ca or +1 800 363 6360



CONTACT FORM



CALL NOW